

Installation Instructions

CUSTOM QUICK INSTALL MOUNTING KIT

FORD SUPER DUTY

Part Numbers:
50074

WARNING: Under no circumstances do we recommend exceeding the towing vehicle manufacturers recommended vehicle towing capacity.

Equipment Required:

Fastener Kit: 50074F

Wrenches: 3/4", 15/16"

Drill Bits: 1/8" & 9/16"

Other Tools: Center Punch, Measuring Tape, Torque Wrench

****THIS RAIL MOUNTING KIT USES 11 BOLTS****



VEHICLE FORWARD

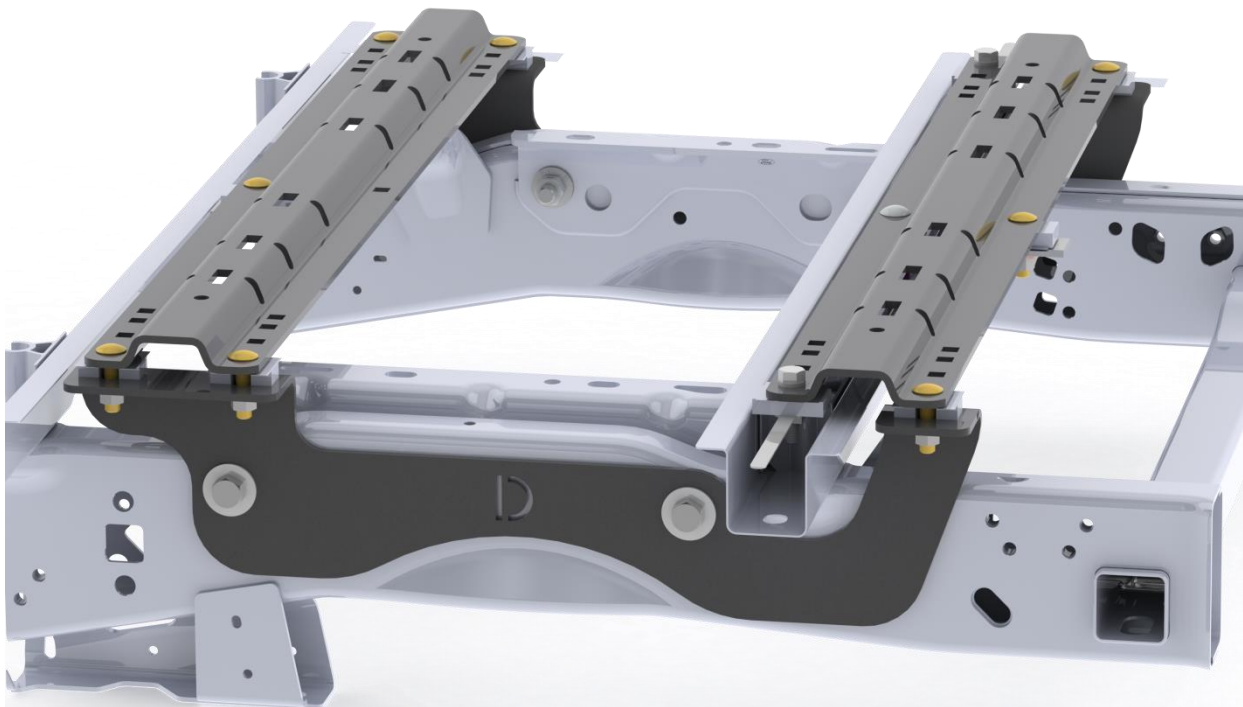

Figure 1

- Do not install mounting rails over plastic bed liners. Plastic bed liners must be cut out of the way to provide metal to metal contact. Mounting rails may be installed on spray in liners.
- Use only bolts, nuts, and washers supplied to install this kit. All bolts and nuts are Grade 5 unless otherwise specified.
- These instructions are guidelines only, actual installation is the responsibility of the installer and the owner. Always measure truck and trailer before installing hitch to be sure that there is clearance at the cab and at the bumper to allow for turns.
- Do not install this product on or attempt to tow with a truck with a 5-1/2' bed unless a sidewinder pin box coupler has been installed on the trailer.

IMPORTANT: Contact between any bare steel components (frame mounting brackets, U-shaped spacers, mounting rails, etc.) and bare aluminum bed may cause corrosion over it's life. Insure that the paint is not damaged on the brackets. This kit also includes galvanic isolators that provide an extra layer of protection- use galvanic isolator squares (13) or galvanic isolator strips (11),(12), & (14) on the surface that will make contact with the truck bed. See Figure 4, Figure 5, & Figure 6. Repaint any areas where holes were drilled through bed.

Installation Instructions

1. Lower and remove spare tire if extra room is needed. If equipped with inner plastic wheel well liner, remove inner plastic wheel well liners to allow access to frame.
2. Place the galvanic isolator strips (14) on the bottom surface of each rail to protect aluminum truck bed as shown.(See Figure 3)
Note: It is important that the galvanic isolator strips (14) are installed correctly to avoid corrosion between the mounting rails and truck bed over its life.
3. Place the rear mounting rail in the box of the truck, using your tape measure, center the rail between the weld seams on the length of the truck box floor/ or the wheel well and the proper distance from the rear edge of the truck. (See Figure 2)
4. Mark and center punch the holes as per the illustrations. Move the rail out of the way and drill each position with a 1/8" drill bit. (See Figure 2)
Warning: When drilling holes be aware of potential risks to vehicle components above and below the truck bed and make appropriate safe guards to protect them from damage.
5. Install the galvanic isolator strips (11) &(12) on the frame brackets (18) & (19) .(See Figure 6)
6. Loosely install the frame brackets (18) & (19) using the appropriate hardware and hand tighten. (See Figure 3)
 - 1.) Place a 5/8" flat washer (8) over each of the 5/8-11 x 4-1/4" hex head bolts (6).
 - 2.) Position the frame brackets (18) & (19) over the frame mounting holes, and route the 5/8-11 x 4-1/4" hex bolt (6) through the frame bracket and vehicle frame from the outside of the frame to the inside of the frame as shown. (See Figure 3).
 - 3.) Install the 5/8 conical washer (9) and then the 5/8-11 nut (7) over the 5/8-11 x 4.25 hex head bolt (6) and hand tighten.
7. Check that the 1/8" drilled holes from step 4 align with the slots of the frame bracket (18) & (19). If holes do not align, adjust the frame brackets as needed. If this does not align the holes, restart the installation at step 4. When the holes align with the rails and brackets, remove the rails and brackets and proceed to step 8.
8. Enlarge the 1/8" drilled holes to 9/16", **EXCEPT ROW 3 CENTER BOLT**. Warning: When drilling holes be aware of potential risks to vehicle components above and below the truck bed and make appropriate safe guards to protect them from damage, paint all bare metal.
9. **Drill a 1/8" hole in the center bolt location of row 3 through the truck bed and the truck bed cross member/sill/hat section. Enlarge the 1/8" hole to 1-1/8" IN THE TRUCK BED ONLY. Enlarge the 1/8" hole in the truck bed cross member/sill/hat section to 9/16"**. Warning: When drilling holes be aware of potential risks to vehicle components above and below the truck bed and make appropriate safe guards to protect them from damage, paint all bare metal.
10. **Place the tube spacer (20) in the center rail bolt location in Row 3. (See Figure 3)**
11. Reposition the mounting rail over the holes.
12. Install the rear rail attachment bolts as shown in figure (3).Ensure that the galvanic isolator patches (13)are installed on the U-shaped spacers and spacer blocks as shown. (See figures 4 & 5) Attach the 1/2" conical washers (16) and hex nuts (15) on the bottom side of the frame bracket (18) & (19) , as per figure 3, and tighten snug to keep the mounting rail from moving. The outer bolts in row 3 of figure 2 will utilize 1/2-13 x 2 hex head bolts (1) on the top of the rail, with a galvanic isolator patch (13), 1/2 x 1 x 2 spacer block (3), and a nut handle (2). **For the center bolt in row 3, which goes through the truck bed cross member/sill/hat section, route the 1/2-13 x 4.50 Carriage bolt (21) through the rail and tube spacer (20), and secure using the .250 x 1.5 x 3 spacer (5), 1/2 conical washer (16), and 1/2-13 nut (15). For the center rail bolt in row 4 of rail attachment bolts, route a 1/2-13 x 2.00 Carriage Bolt (17) though the rail and bed, then secure using a .250 x 1.5 x 3.00 spacer (5), 1/2 " conical washer (16) and 1/2-13 nut (15).**
13. Place the unassembled 5th wheel legs/slider/goose into the already installed mounting rail. Position the second mounting rail with the legs/slider/goose by inserting the tabs into the mounting rail and pushing the mounting rail tight towards the other mounting rail. Ensure that the mounting rail is centered between the weld seams on the length of the truck box floor. This will position the mounting rail in the correct location and ensure that the 5th wheel will have a snug fit to the truck.
Note: If more than one hitch product will be used with the rails then both should be used at the same time to align the second rail. This will ensure that one product does not compromise the fit of the other.
14. Mark and center punch the holes in the front mounting rail as per figure 3. Move the front mounting rail and the frame mounting brackets out of the way, and drill with a 1/8" drill bit.
Warning: When drilling holes be aware of potential risks to vehicle components and make appropriate safe guards to protect them from damage.
13. Repeat steps 6,7, & 8 for the front mounting rail.
14. Install the front rail attachment bolts and spacers as shown in figure (3). Ensure that the galvanic isolator patches are installed on the U-shaped spacers and spacer blocks as shown. (See figures 5 & 6) Attach the 1/2" conical washers (16) and hex nuts (15) on the bottom side of the frame bracket (18 & 19) , as per the illustrations and tighten snug to keep the mounting rail from moving.
15. Torque all hardware.
Note: Torque all Grade 5 1/2" hardware to 75 ft-lbs. Torque all Grade 5 5/8" hardware to 150 ft-lbs. First torque the bed mounting rails to the frame brackets and then torque the frame brackets to the truck frame.
16. Replace inner plastic wheel well liner to body, and spare tire if removed.

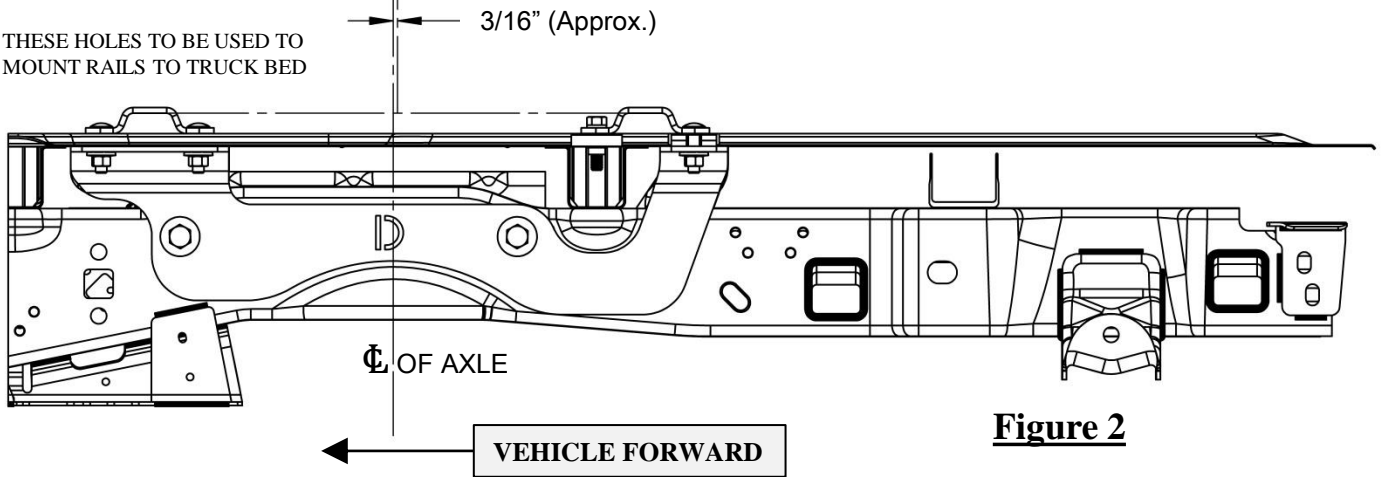
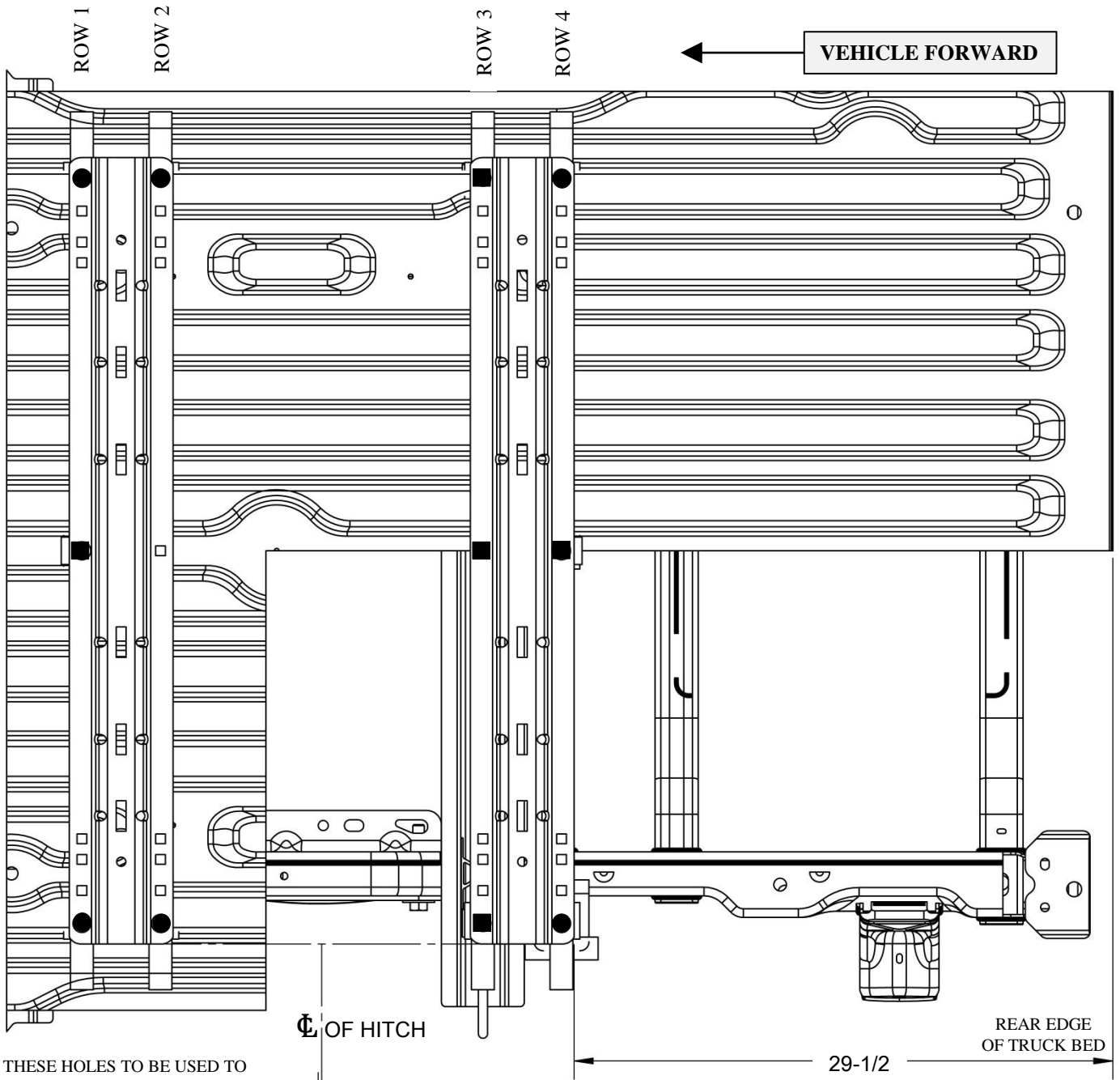

Figure 2

ITEM #	DESCRIPTION	QTY	ITEM #	DESCRIPTION	QTY
1	1/2-13 X 2.00 HEX HEAD BOLT	2	12	1-1/4 X 4 GALVANIC ISOLATOR STRIP	2
2	1/2-13 HANDLE NUT ASSY	2	13	GALVANIC ISOLATOR PATCH	13
3	1/2 X 1 X 2 SPACER BLOCK	4	14	1-1/4 X 48 GALVANIC ISOLATOR STRIP	4
4	1/4 X 1 X 2 U-SHAPED SPACER	12	15*	(1/2-13 GR. 5 NUT)*	10*
5	1/4 X 1-1/2 X 3 SPACER BLOCK	3	16*	(1/2 CONICAL WASHER)*	10*
6	5/8-11 X 4-1/4 GR. 5 HEX HEAD BOLT	4	17*	(1/2-13 CARRIAGE BOLT)*	8*
7	5/8-11 GR. 5 NUT	4	18	Driver Side Bracket	1
8	5/8 FLAT WASHER	4	19	Passenger Side Bracket	1
9	5/8 CONICAL WASHER	4	20	Tube Spacer	1
10*	1/2 HELICAL LOCK WASHER*	2*	21	1/2-13 x 4.50 GR.5 Carriage Bolt	1
11	1-1/4 X 8 GALVANIC ISOLATOR STRIP	2	*Fasteners are supplied with 58058 or 30035 rail kit.		

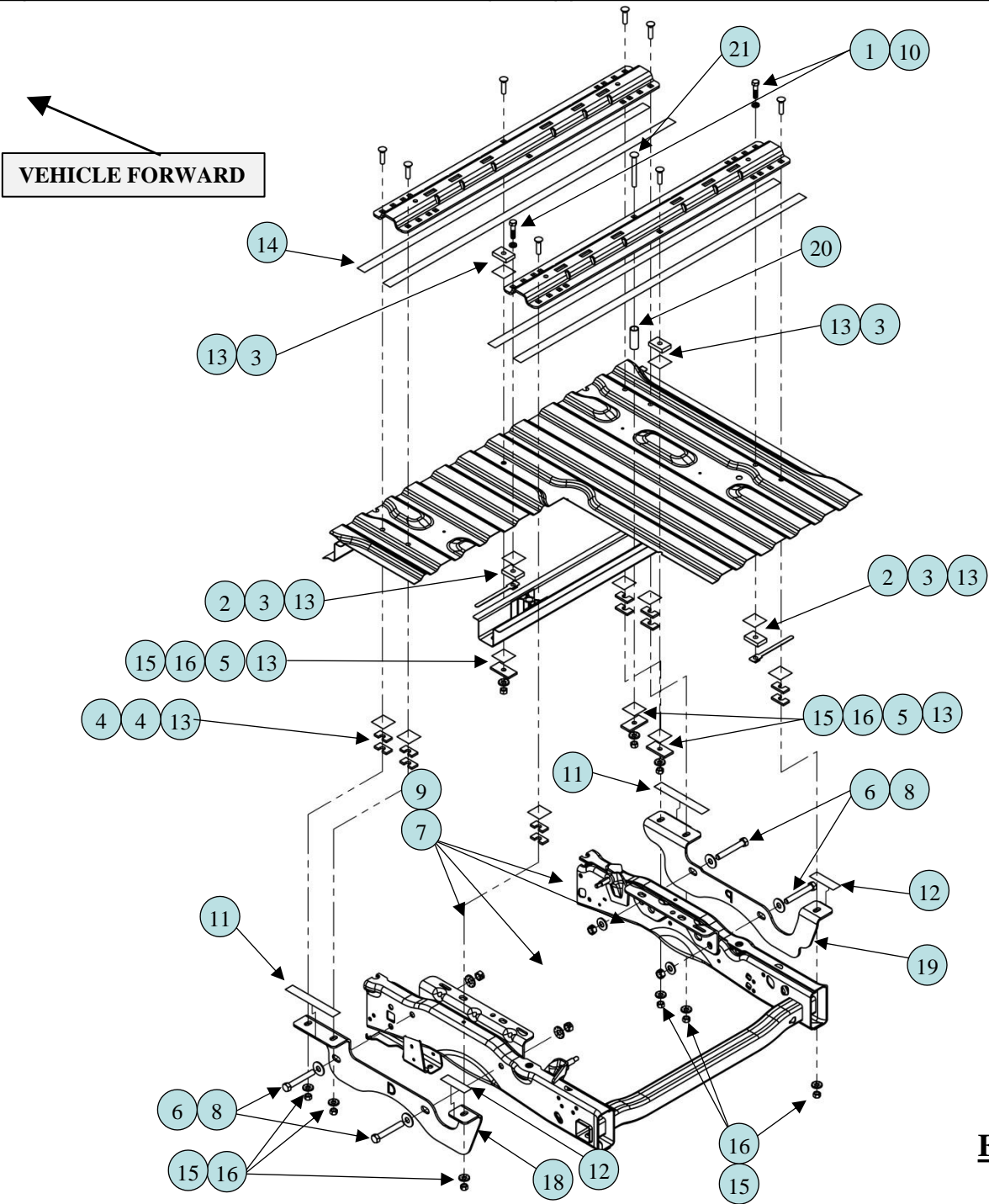

Figure 3

Figure 4 – Isolator Strip on U-Shaped Spacer

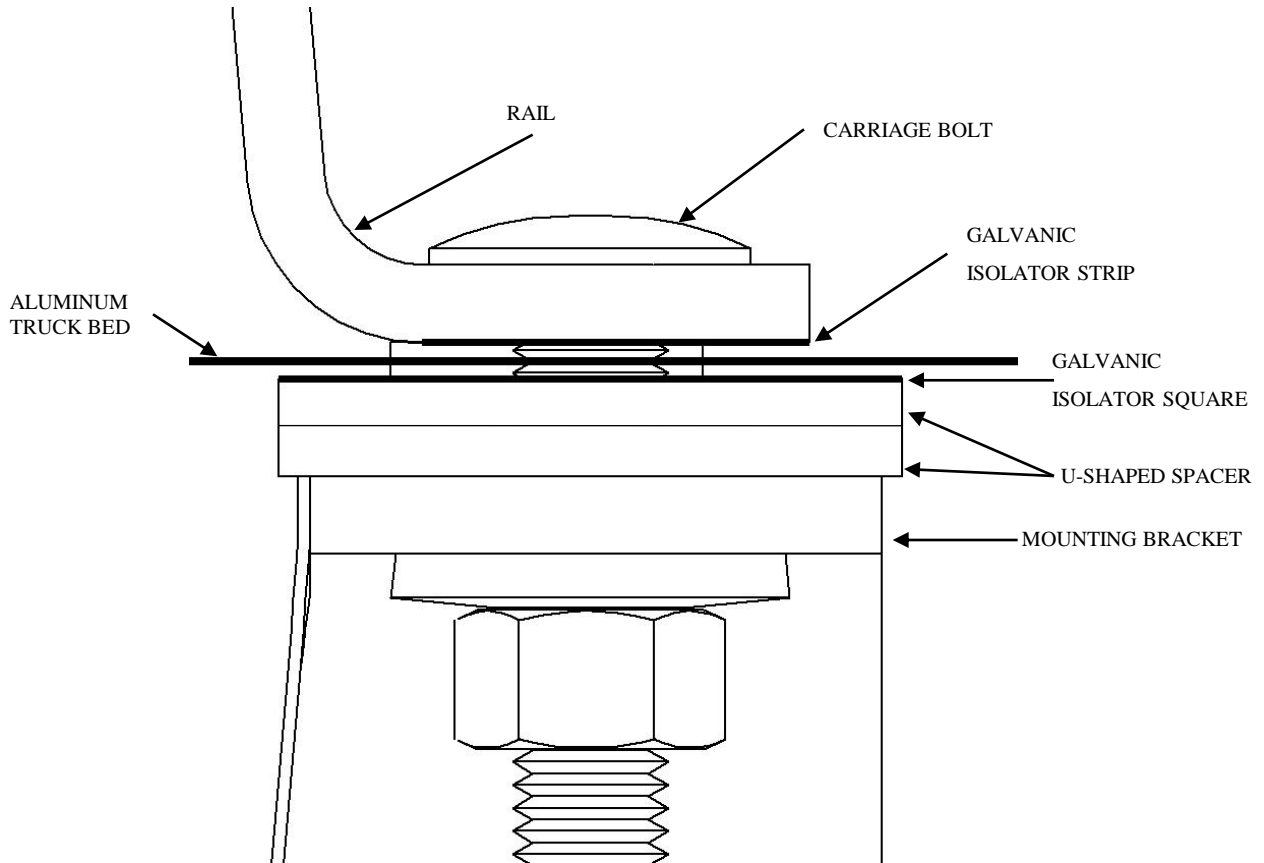

Figure 5 – Isolator Strips on Center Rail Bolt Spacers

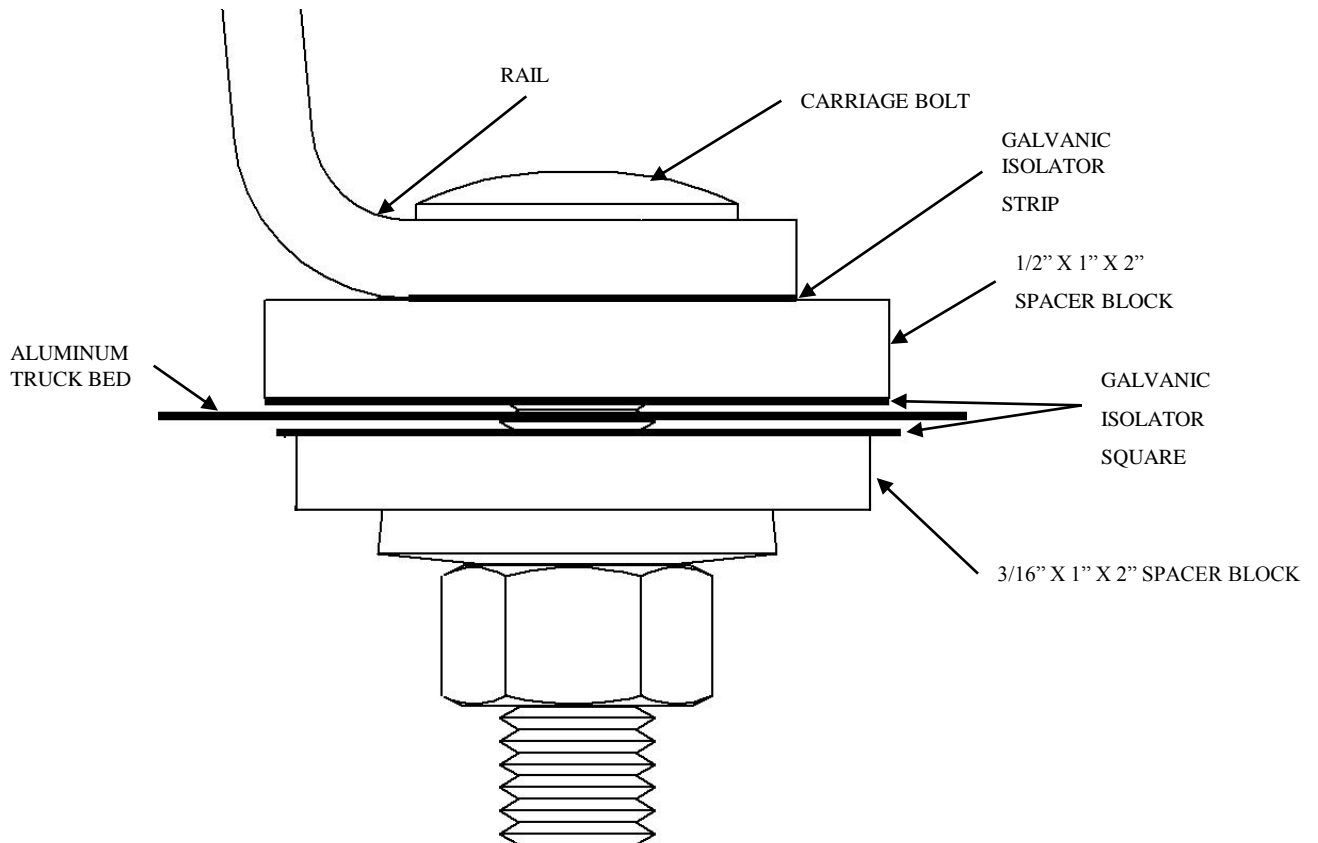
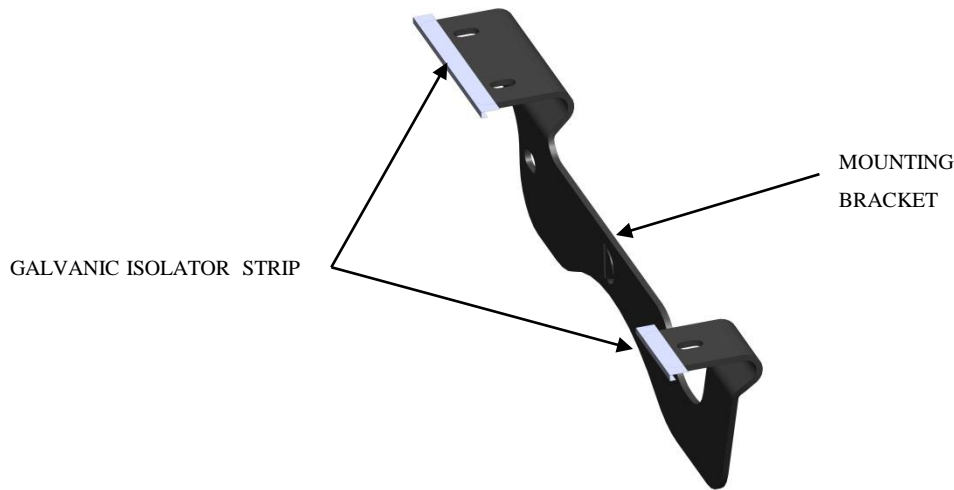

Figure 6 – Isolator Strips on Mounting Brackets



Note: Place galvanic isolator strips on the ends of the bent tabs on the mounting bracket that come into contact with the truck bed. Place them on the end of the bent tabs and folded around the end of the tab, ensuring that at least 3/4" of isolator strip is on the top side of the bracket.

LIMITED TEN YEAR WARRANTY

1. Limited Warranty. Cequent Performance Products, Inc. ("We" or "Us") warrants to the original consumer purchaser only ("You") that the product will be free from material defects in both material and workmanship for a period of five years, ordinary wear and tear excepted; provided that installation and use of the product is in accordance with product instructions. There are no other warranties, express or implied, including the warranty of merchantability or fitness for a particular purpose. If the product does not comply with this limited ten year warranty, Your sole and exclusive remedy is that We will replace the product without charge to You and within a reasonable time or, at our option, refund the purchase price. This warranty is not transferable.

2. Limitations on the Warranty. This limited warranty does not cover: (a) normal wear and tear; (b) damage through abuse, neglect, misuse, or as a result of any accident or in any other manner; (c) damage from misapplication, overloading, or improper installation, including welds; (d) improper maintenance and repair; and (e) product alteration in any manner by anyone other than Us, with the sole exception of alterations made pursuant to product instructions and in a workmanlike manner.

3. Obligations of Purchaser. To make a warranty claim, contact Us, identify the product by model number, and follow the claim instructions that will be provided. Any returned product that is replaced or refunded by Us becomes our property. You will be responsible for return shipping costs. Please retain your purchase receipt to verify date of purchase and that You are the original consumer purchaser. The product and the purchase receipt must be provided to Us in order to process Your warranty claim.

4. Remedy Limits. Repair or replacement is Your sole remedy under this limited warranty or any other warranty related to the product. We shall not be liable for service or labor charges incurred in removing or replacing a product or any incidental or consequential damages of any kind.

5. Assumption of Risk. You acknowledge and agree that any use of the product for any purpose other than the specified use(s) stated in the product instructions is at Your own risk.

6. Governing Law. This limited warranty gives You specific legal rights, and You also may have other rights which vary from state to state. This limited warranty is governed by the laws of the State of Michigan, without regard to rules pertaining to conflicts of law. The state courts located in Oakland County, Michigan shall have exclusive jurisdiction for any disputes relating to this warranty.