

READ THIS FIRST:

Read and follow all instructions carefully before beginning installation.

Installation Instructions



7-WAY FLAT PIN CONNECTOR / 4-FLAT COMBO ADAPTER HARNESS P/N 74682

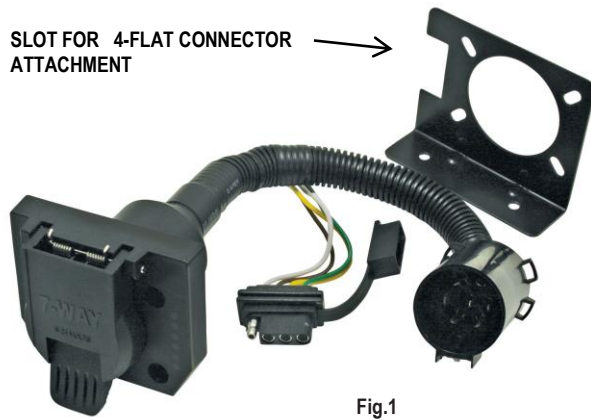
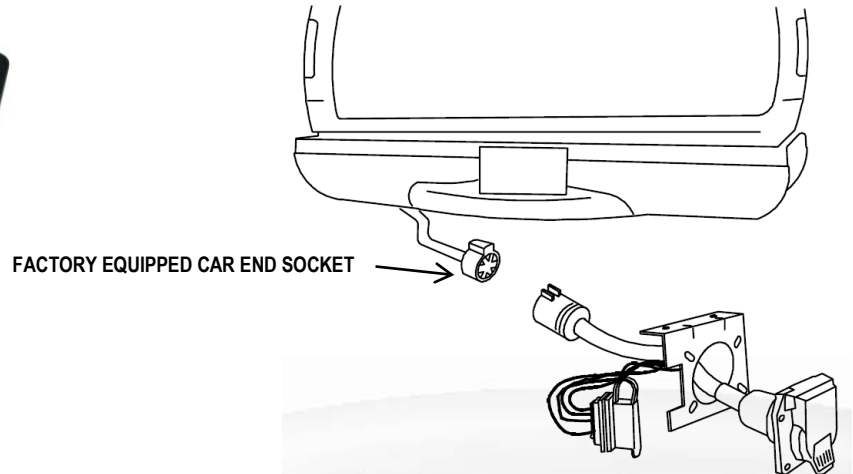

Fig.1



TOOLS REQUIRED:

Philips Head Screwdriver, adjustable wrench.

MOUNTING BRACKET INSTRUCTIONS:

1. Determine a suitable mounting point on the tow vehicle for the connector or use existing mount. Make sure that the trailer's wire harness has adequate length to reach this point and mount the connector using the mounting bracket and screws and hex nuts provided.
2. First secure mounting bracket on rear of the tow vehicle or to the plate attached to hitch cross tube using self-tapping screws.

⚠ CAUTION

Do not drill into the hitch cross tube to avoid damage to the hitch and /or personal injury. Do not drill into any exposed surfaces. Consult hitch owner manual or instruction sheet for recommendation and limitations.

SOCKET INSTRUCTIONS:

1. Install the 7-way Blade Socket (connector) on to the mounting bracket using the screws and nuts provided.
2. Plug the OEM factory equipped car end socket harness as shown on Fig.2, into the 7-way Blade Car Socket.
3. Install 4 flat connector into slot in bracket, shown on the Fig.1
4. Tighten screws.

⚠ WARNING

All connections must be complete to function properly. Test and verify installation with a test light, circuit tester or trailer once installed.

🔥 ⚠ WARNING

Overloading circuit can cause fires. **DO NOT** exceed lower of towing manufacturer rating or:

- Max. Right Turn, Left Turn, Stop, & Tail Light Circuits: (7.5 amps)
- Max. (+) Battery, Reverse, and Electric Brake Circuits: (30 amps)
- Read vehicle's owner's manual & instruction sheet for additional information. Additional fusing may be required.