

REESE

You *can* take it with you.

INSTALLATION INSTRUCTIONS

Trunnion Style

Weight Distributing Kits

HIGH-PERFORMANCE BALLMOUNT

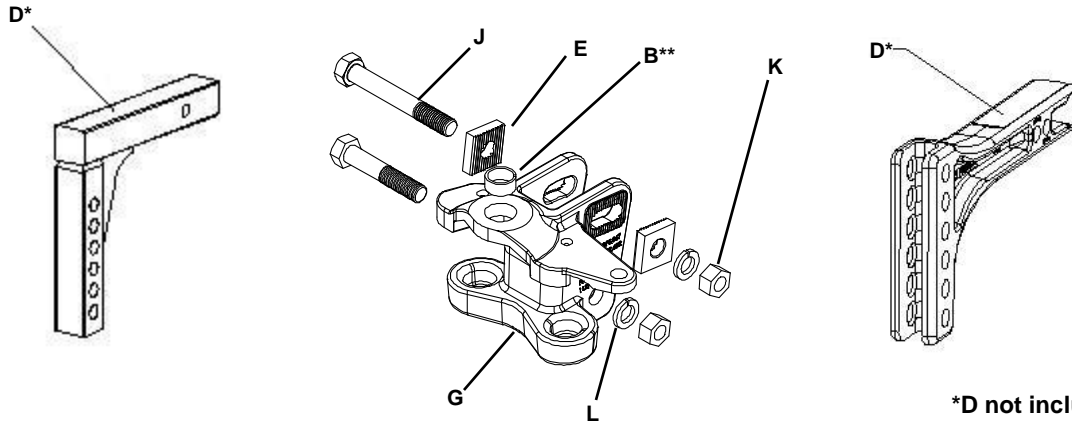

***D not included in all kits**
****B not included in all kits**

INITIAL SET-UP

1. Line up tow vehicle and trailer on level pavement, in straight-ahead position, uncoupled.
2. Level the trailer and measure and record the distance from the ground to the top of the ball socket (X dimension Fig.1).
3. Select a hitch ball with a diameter that matches the trailer coupler size. The three most common sizes are 1-7/8", 2", and 2-5/16". Select ball with 1-1/4" or 1" threaded shank that is V-5 rated equal to or greater than trailer gross vehicle weight rating (GVWR).

WARNING: Raised balls usually have reduced load ratings. Ball rating MUST equal or exceed trailer GVWR.

4. Attach hitch ball to the ballmount (G). Standard height hitch balls with 1-1/4" shanks are supplied with lock washers and nuts (If you must use a 1" shank ball, use bushing 58184 (B) to reduce hole size in ballmount (G) to 1"). Always use a lock washer and place washer next to nut. Unless otherwise specified by ball manufacturer torque ball nut to 450 ft/lbs for 1-1/4" nut, 250 ft/lbs for 1" nut.
5. Some installations may require a longer hitch bar (D). Extended bumper guards, pickup truck "caps", or rear mounted spare tires can limit turn angles unless a longer bar is used. Individual hitch bars (D) are available in various sizes.
6. Insert the hitch bar (D) into the hitch box and install a pull pin. Place ballmount (G) onto hitch bar and move up or down for proper height. Hitch bar may be used in either the up or down position (see below).

NOTE: Ball height should be greater than coupler height (measured in step 1) to compensate for vehicle "squat" (approximately 3/4" to 1").

HIGHEST POSITION

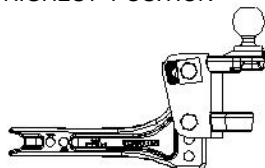

LOWEST POSITION

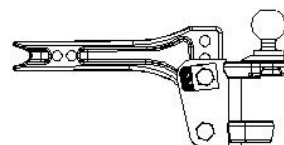

For vehicles with air springs, air shocks or automatic leveling system, check vehicle owners manual. Unless otherwise specified, level the vehicle with the vehicle loaded as it will be when towing before setting ball height and attaching trailer.

PRELIMINARY BALLMOUNT ADJUSTMENT

1. Install hardware in lower hole of ballmount as shown. Tighten nut enough to prevent easy rotation of ballmount.
2. Determine spring bar height "Y" using table below. Insert spring bar and trunnion into the ball mount. Swing bar outward to the same angle as when connected to trailer. Lift up on bar to remove slack. Tilt ball mount for proper "Y" dimension at end of spring bar.

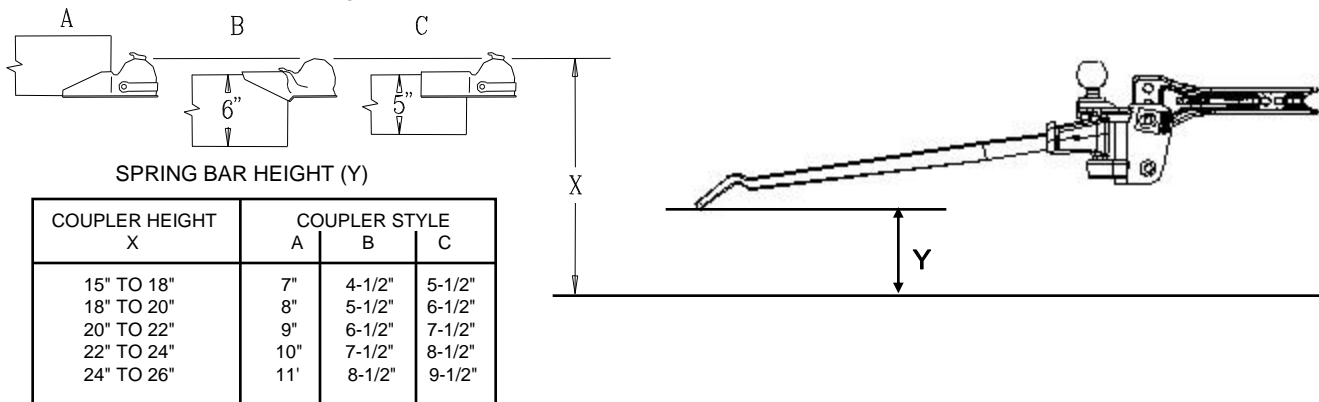

*** ADD 1" TO Y DIMENSION FOR NON-INTEGRATED CAM SPRING BARS.**

3. The ballmount (G) is adjustable through a 15° angle range for proper spring bar adjustment. See chart above.

HIGH-PERFORMANCE BALLMOUNT ADJUSTMENT

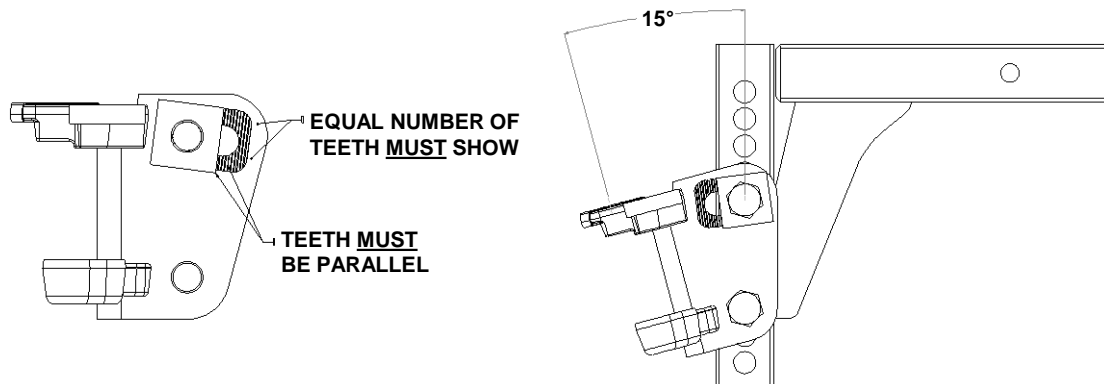

Install longer 3/4" bolt (J) with two serrated washers (E) as shown. Install lock washer (L) and nut (K), but allow space for washers to be positioned and aligned. Align the washers as shown, hold in position, and tighten nut. Torque the two nuts (K) to 300 ft/lbs. If proper torque wrench is not available, torque nuts to 150 ft/lbs then turn nuts an additional 1/4 turn. Do not lubricate the threads.

OPTIONAL SHIM KIT

Use the shim provided when needed to fill any gap between the Weight Distributing Head shown below and the hitch bar used in the particular application.

It is easier to install the shim from the top down as shown on the following page. In doing so, you will encounter one of three scenarios:

1. *Shim will go all the way down to line up with the bottom hole.* If this is the case, use the entire shim in the gap.

Note: It is conceivable that in some rare combinations, two shims could be used.

2. Shim will not begin to fit between the head and hitch bar. If this is the case, discard shim and continue installation. The existing gap is acceptable
3. Shim will not go in far enough to reach bottom hole. If this is the case, cut shim in half and use only the top half for the top bolt. Discard bottom half of shim.

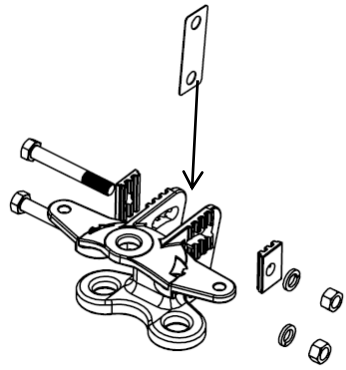

CAUTION: Washer **MUST BE** aligned parallel with teeth on ballmount. Re-check washer alignment after nut is tightened. Equal number of teeth must show at top and bottom. Teeth can be stripped when loaded if not properly aligned.

INITIAL HOOK UP

NOTE: Car and trailer should be loaded and ready for travel before final leveling.

1. Pick reference points on front wheel well. Measure and record distance to pavement. Front wheel well to pavement _____
2. Attach chains to spring bars using U-bolts, flat washers, and locknuts. Let 2-3 threads protrude below locknut. Chain must not bind.

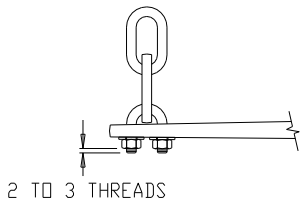

STANDARD SPRING BAR

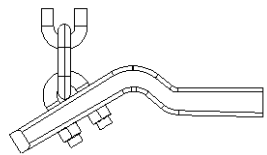

INTEGRATED CAM SPRING BAR

3. Using tongue jack lower coupler onto ball and close coupler latch.
4. Hold the spring bar away from you (trunnion ribbed side up). Set the bottom knob of the trunnion into the lower socket of the ballmount (G) and slide the knob into the top slot of the ballmount. The spring bars will fit on either side as they are not made right or left handed.

5. Position the snap up brackets on trailer "A" frame so that the chain on the end of the spring bar is approximately vertical. Turn 1/2 X 3-1/2 bolt until it contacts frame. Then tighten 1/4 turn with wrench. **DO NOT OVERTIGHTEN.**

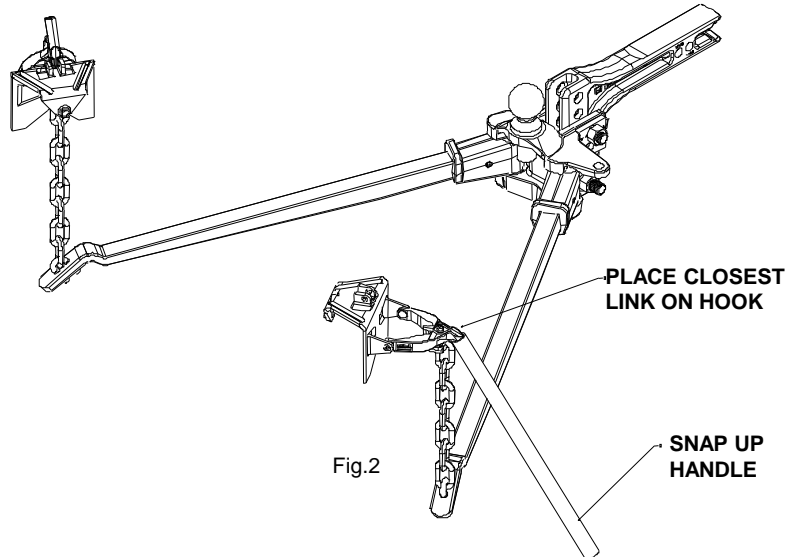

6. Raise trailer tongue and rear of car with jack. Lower yoke of snap up bracket until it is parallel with the ground, and slip the closest link over the hook (If there are less than 5 links between hook and u-bolt adjust ballmount angle rearward, and repeat procedure). With the snap up bracket handle over the yoke, raise until yoke has passed "over-center". Slide the safety pin through the small hole to lock the yoke in place. Repeat for other side.

7. Lower jack. Re-measure front wheel well reference point. The front wheel well height should be equal to the original measurement. If the front wheel well height is higher than originally measured, reduce the number of links between the yoke hook and spring bar (4 links min.) and recheck the wheel well measurement. If the front wheel well is lower than originally measured, increase the number of chain links between the yoke hook and spring bar and recheck the wheel well measurement. If the original wheel well height is not achievable, it is preferred that the wheel well height is lower after the spring bars are loaded. If there are no more chain links for adjustment, the head assembly must be tilted forward. The trailer must be uncoupled and the upper bolt removed from the head assembly. The head is then pivoted up as appropriate. Reassemble and recheck the wheel well height.
8. A new term in the industry is ("FALR" – Front Axle Load Return). 100% FALR Means the front fender is returned to the preload position. That is our recommendation for best performance.

Check to see if trailer is level, if not, you may need to re-adjust ballmount angle and / or position.

Check to see that there is room for the bar and chain to move when turning a corner.

NOTE: Some surge brakes will not work with weight distributing hitches. Check with manufacturer. Do not use sway control with surge brakes.

LUBRICATION

1. Lubricate the ballmount sockets and spring bar trunnions to prevent rapid wear. When hooking-up, place one drop of oil on the top and a second drop on forward side of upper trunnion. Place a third drop on the rear side of lower trunnion before inserting trunnion into ballmount. Use a heavy oil or grease. Don't forget to lubricate the hitch ball with one or two drops also. Trunnions should be lubricated each towing day. It is not necessary to unhook the spring bars however, as there are two oil holes in the ballmount top plate for upper trunnion lubrication. Lubricate lower trunnions with one drop at contact point between trunnion and lower socket. Excess oil, dirt, and grit should be wiped out whenever trailer is uncoupled.

Installation Instructions For Snap Up Bracket

Provides For a Stronger Attachment to the Trailer Frame

TOOLS NEEDED:

Drill Bits: 7/16",
9/16" & 1/4"

⚠ WARNING:

Read all instructions before installing the additional bolt.
Failure to follow all of these instructions may result in death or serious injury!

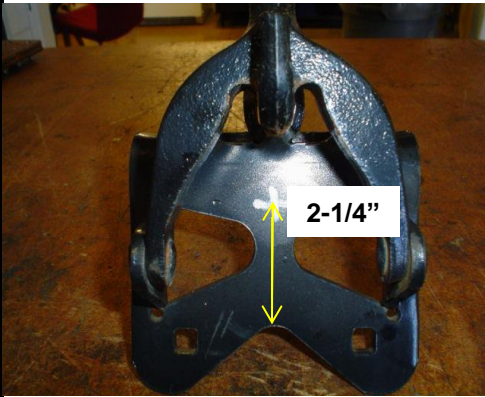

- Installation of an additional bolt into the snap up bracket.

- If your bracket does not already have a hole in this location, mark the location of the hole to be drilled into the snap up bracket. Center the hole from left to right and place it 2-1/4" above the arc in the bracket. See the picture at left.

- Before the bracket is placed on the frame, drill a 9/16" hole in the bracket



- Place the bracket in the correct place on the frame as directed in the product instructions or replace it where it was if it had already been installed.

- Using the hole in the bracket as a guide, drill a 1/4" pilot hole. Be sure to stay centered in the bracket hole.

- One method to stay centered is to use the 9/16" drill first. Just put a small dimple into the frame with the 9/16" bit. Then finish drilling with the 1/4" drill bit and then a 7/16" drill bit to get the final hole. See pilot hole to the left.



- Install the 1/2" self tapping screw into the hole in the bracket and frame. Tighten it to 50 ft/lbs.

- Re-tighten the 1/2" set screw on the inside of the frame. Turn only 1/4 to 1/2 of a turn after making contact with the frame.

PARTS LIST	
QTY	DESCRIPTION
2	1/2" x 1.00" SELF TAPPING SCREW
1	INSTRUCTION SHEET

Self Tapping
Screw is available
in service kit
58459 if needed.

WARNINGS: LOADED BALL HEIGHT SHOULD NEVER BE GREATER THAN UNCOUPLED BALL HEIGHT. Front wheel overload and loss of rear wheel traction can result, and can lead to unstable handling, reduced braking ability, and a tendency to "jackknife" when turning and braking at the same time. IF LOADED BALL HEIGHT IS GREATER THAN UNCOUPLED HEIGHT, reduce take-up on spring bar chains and re-measure until proper height is obtained.

DO NOT TOW MULTIPLE TRAILERS: Do not attempt to tow any type of trailer behind another trailer. Towing multiple trailers may cause severe instability, loss of control and/or structural failure, and may result in vehicle accident, property damage and personal injury. Towing multiple trailers is illegal in many jurisdictions.

FRONT-WHEEL-DRIVE VEHICLES: DO NOT ATTEMPT TO HOOK-UP OR TOW WITH REAR WHEELS OF TOWING VEHICLE REMOVED. Severe structural damage to towing vehicle, hitch, and trailer may result. A towing vehicle/trailer combination cannot be controlled adequately unless the towing vehicle's rear wheels are carrying their share of the load.

MAINTENANCE: Keep trunnions and sockets in head assembly free of dirt and well lubricated. Excessive wear in this area may indicate overload or inadequate lubrication. Some elongation of socket openings "seat in" is normal.

Keep head assembly exterior clean, especially the trunnion sockets. Do not allow dirt or stones to lodge between trunnions and head.

Keep hitch painted to prevent rust and maintain a good appearance. (Do not paint over labels)

AT THE BEGINNING OF EVERY TOWING DAY:

- Add drop of oil at trunnion contact areas with ball mount.
- Clean ball and coupler socket and coat ball lightly with grease.
- Check spring bar chains and U-bolts for wear. Replace before they become worn halfway through.
- Check to see that all bolts are properly tightened and hitch pin and clip are securely in place.
- Check to see that electrical hookups are in working order, and that safety chains are connected.

TOWING TIPS

DRIVING: Good habits for normal driving need extra emphasis when towing. The additional weight affects acceleration and braking, and extra time should be allowed for passing, stopping, and changing lanes. Signal well in advance of a maneuver to let other drivers know your intentions. Severe bumps and badly undulating roads can damage your towing vehicle, hitch, and trailer, and should be negotiated at a slow steady speed. IF ANY PART OF YOUR TOWING SYSTEM "BOTTOMS" OUT, OR IF YOU SUSPECT DAMAGE MAY HAVE OCCURED IN ANY OTHER WAY, PULL OVER AND MAKE A THOROUGH INSPECTION. CORRECT ANY PROBLEMS BEFORE RESUMING TRAVEL.

CHECK YOUR EQUIPMENT: Periodically check the condition of all your towing equipment and keep it in top condition.

TRAILER LOADING: Proper trailer loading is important. Heavy items should be placed close to the floor near the trailer axle. The load should be balanced side-to-side and firmly secured to prevent shifting. Tongue weight should be about 10-15 percent of the gross trailer weight for most trailers. Too low a percentage of tongue weight will often produce a tendency to sway. Excess weight on the tongue can also lead to sway and damage hitch and / or tow vehicle.

SWAY CONTROLS: A sway control can help minimize the affects of sudden maneuvers, wind gusts, and buffeting caused by other vehicles. Use of a sway control is recommended for trailers with large surface areas, such as travel trailers.

TIRE INFLATION: Unless specified otherwise by the towing vehicle or trailer manufacturer, tires should be inflated to their maximum recommended pressure.

TOWING VEHICLE AND TRAILER MANUFACTURERS' RECOMMENDATIONS: Review the owners' manuals for your towing vehicle and trailer for specific recommendations, capacities, and requirements.

POLE TONGUE TRAILERS: If your trailer has a straight tongue (instead of an A-frame tongue), it will be necessary to use a pole tongue adapter. This adapter attaches to the trailer tongue, providing a place to attach the snap up brackets.

PASSENGERS IN TRAILERS: Trailers should NOT be occupied while being towed, under any circumstances.

TRAILER LIGHTS, TURN SIGNALS, AND ELECTRIC BRAKES: Always hook up trailer lights, turn signals, electric brakes and break-away switch connection (if so equipped) even for short trips.

REMOVE HITCH WHEN NOT TOWING: Remove hitch from towing vehicle receiver when not towing, to prevent contamination of head sockets, reduce chance of striking hitch on driveway ramps or other objects, and minimize damage in the event of a rear-end collision.