

Installation Instructions

CUSTOM QUICK INSTALL

MOUNTING KIT

FORD F-150

Part Numbers:
50087

Equipment Required:

Fastener Kit: 50087F

Wrenches: 3/4", 7/8", 18mm

Drill Bits: 1/8" & 9/16"

Other Tools: Center Punch, Measuring Tape

WARNING: Under no circumstances do we recommend exceeding the towing vehicle manufacturers recommended vehicle towing capacity.

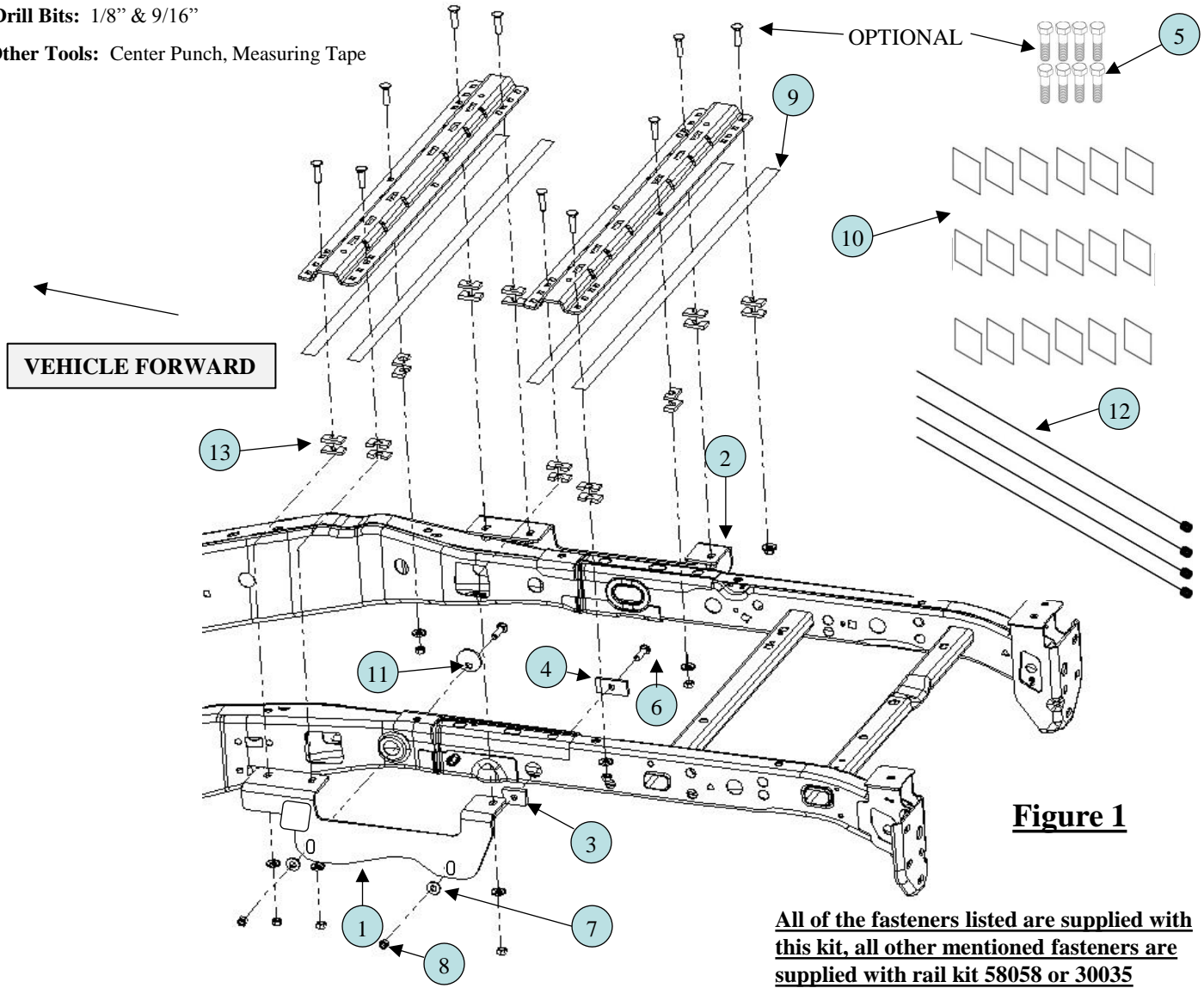

Figure 1

All of the fasteners listed are supplied with this kit, all other mentioned fasteners are supplied with rail kit 58058 or 30035

1	DRIVER BRACKET	1	7	CONICAL WASHER, 1/2"	4
2	PASSENGER BRACKET	1	8	1/2" NUT GR. 5	4
3	BLOCK, .50" X 1.5" X 2"	2	9	GALVANIC ISOLATOR STRIP	4
4	BLOCK, .25" X 1.5" X 3"	2	10	GALVANIC ISOLATOR SQUARE	18
5	HEX BOLT, 1/2"-13 X 2" GR. 5	8	11	CIRCLE BLOCK	2
6	CARRIAGE BOLT, 1/2"-13 X 2" GR. 5	4	12	PULL WIRE (1/2" -13)	4
			13	U-SHAPED SPACER, .1875" X 1" X 2"	20

- Do not install mounting rails over plastic bed liners. Plastic bed liners must be cut out of the way to provide metal to metal contact. Mounting rails may be installed on spray in liners.
- Use only bolts, nuts, and washers supplied to install this kit. All bolts and nuts are Grade 8 unless otherwise specified.
- These instructions are guidelines only, actual installation is the responsibility of the installer and the owner. Always measure truck and trailer before installing hitch to be sure that there is clearance at the cab and at the bumper to allow for turns.
- Do not install this product on or attempt to tow with a truck with a 5-1/2' bed unless a sidewinder pin box coupler has been installed on the trailer.

IMPORTANT: Contact between any steel components (frame mounting brackets, U-shaped spacers, mounting rails, etc.) and aluminum bed may cause corrosion. Insure that the paint is not damaged on the brackets and use galvanic isolator squares (9) or galvanic isolator strips (8) on the surface that will make contact with the truck bed. See Figure 4 and Figure 5. Repaint any areas where holes were drilled through bed.

Installation Instructions

1. Lower and remove spare tire if extra room is needed. If equipped with inner plastic wheel well liner, remove inner plastic wheel well liners to allow access to frame.
2. Place the galvanic isolator strips (9) on the bottom surface of each rail to protect aluminum truck bed as shown in Figure 1.

Note: It is important that the galvanic isolator strips (9) are installed correctly to avoid corrosion between the mounting rails and truck bed.
3. Place the rear mounting rail in the box of the truck, using your tape measure, center the rail between the weld seams on the length of the truck box floor and the proper distance from the rear edge of the truck see Figure 2.
4. Mark and center punch the holes as per the illustrations. Move the rail out of the way and drill each position with a 1/8" drill bit.

Warning: When drilling holes be aware of potential risks to vehicle components and make appropriate safe guards to protect them from damage.
5. Loosely install the frame brackets (1) & (2) using the appropriate hardware and hand tighten. (See Figure 1)

Note: If the U-shaped spacers (step 9) are on the top side of the truck bed, the frame brackets (1) & (2) must have galvanic isolator squares placed at the mounting hole of each mounting point through the truck bed. Failure to do so may cause corrosion of the truck bed.

 - Starting with the rear mounting hole first, insert the coiled end of the pull wire (12) through the 1-1/2" diameter mounting hole on the side of the truck frame and out through the large oval access hole on the inside of the frame.
 - Slide the block (4) over the coiled end of the pull wire and attach the 1/2" x 2" carriage bolt (6).
 - Push the hardware up into the frame through the large oval access hole on the inside of frame.
 - With the other end of the pull wire (12), thread it through the 1/2" thick block (3) then through the back side of the frame bracket (1) & (2) and gently pull on the end of the pull wire (12) so that the hardware moves through the frame and into position in the frame bracket.
 - Install the 1/2" conical washer (7) and 1/2" nut (8) and hand tighten.
 - For the forward mounting hole, insert the coiled end of the pull wire (12) through the 1-1/2" diameter mounting hole on the side of the truck frame and out through the large oval access hole on the inside of the frame.
 - Slide the circle block (11) over the coiled end of the pull wire and attach the 1/2" x 2" carriage bolt(6).
 - Push the hardware up into the frame through the large oval access hole on the inside of the frame.

Note: It is important that square hole in the circle block (11) sits at the bottom of the mounting hole on the frame as shown in Figure 1. The circle block (11) should fit inside embossment in truck frame.

 - With the other end of the pull wire (12), thread it through the back side of the frame bracket (1) & (2) and gently pull on the end of the pull wire (12) so that the hardware moves through the frame and into position in the frame bracket.
 - Install the 1/2" conical washer (7) and 1/2" nut (8) and hand tighten.
6. Check that the 1/8" drilled holes from step 4 align with the slots of the frame bracket (1) & (2).
7. Enlarge the 1/8" drilled holes to 9/16". Warning: When drilling holes be aware of potential risks to vehicle components and make appropriate safe guards to protect them from damage, paint all bare metal.
8. Reposition the mounting rail over the holes.
9. Install the 1/2" x 2" carriage bolts with the U-shaped spacer(x2) to be located in the corrugation between the box and the mounting rail or between box and frame bracket (1) & (2). The 1/2"-13 x 2" hex head bolts (5), may be used in place of the carriage bolts on the outer rail attachment if it is difficult to install carriage bolts. This prevents crushing the bed corrugation. The U-shaped spacers must have the 2" x 2" galvanic isolator squares (10) placed on the side making contact with the truck bed (Figures 3 & 4). Attach the washers and hex nuts on the bottom side of the frame bracket (1 & 2) , as per the illustrations and tighten snug to keep the mounting rail from moving.
10. Place the unassembled 5th wheel legs/slider/goose into the already installed mounting rail. Position the second mounting rail with the legs/slider/goose by inserting the tabs into the mounting rail and pushing the mounting rail tight towards the other mounting rail. Ensure that the mounting rail is centered between the weld seams on the length of the truck box floor. This will position the mounting rail in the correct location and ensure that the 5th wheel will have a snug fit to the truck.

Note: If more than one hitch product will be used with the rails then both should be used at the same time to align the second rail. This will ensure that one product does not compromise the fit of the other.
11. Repeat steps 4,6,7, 8 & 9 for front mounting rail.

Note: Torque all 1/2" hardware to 75 ft-lbs. First torque the mounting rails to the frame brackets and then torque the frame brackets to the truck frame.
12. Replace inner plastic wheel well liner to body, and spare tire if removed.

Installation Instructions

CUSTOM QUICK INSTALL

MOUNTING KIT

Ford F-150

Part Numbers:
50087

Figure 2

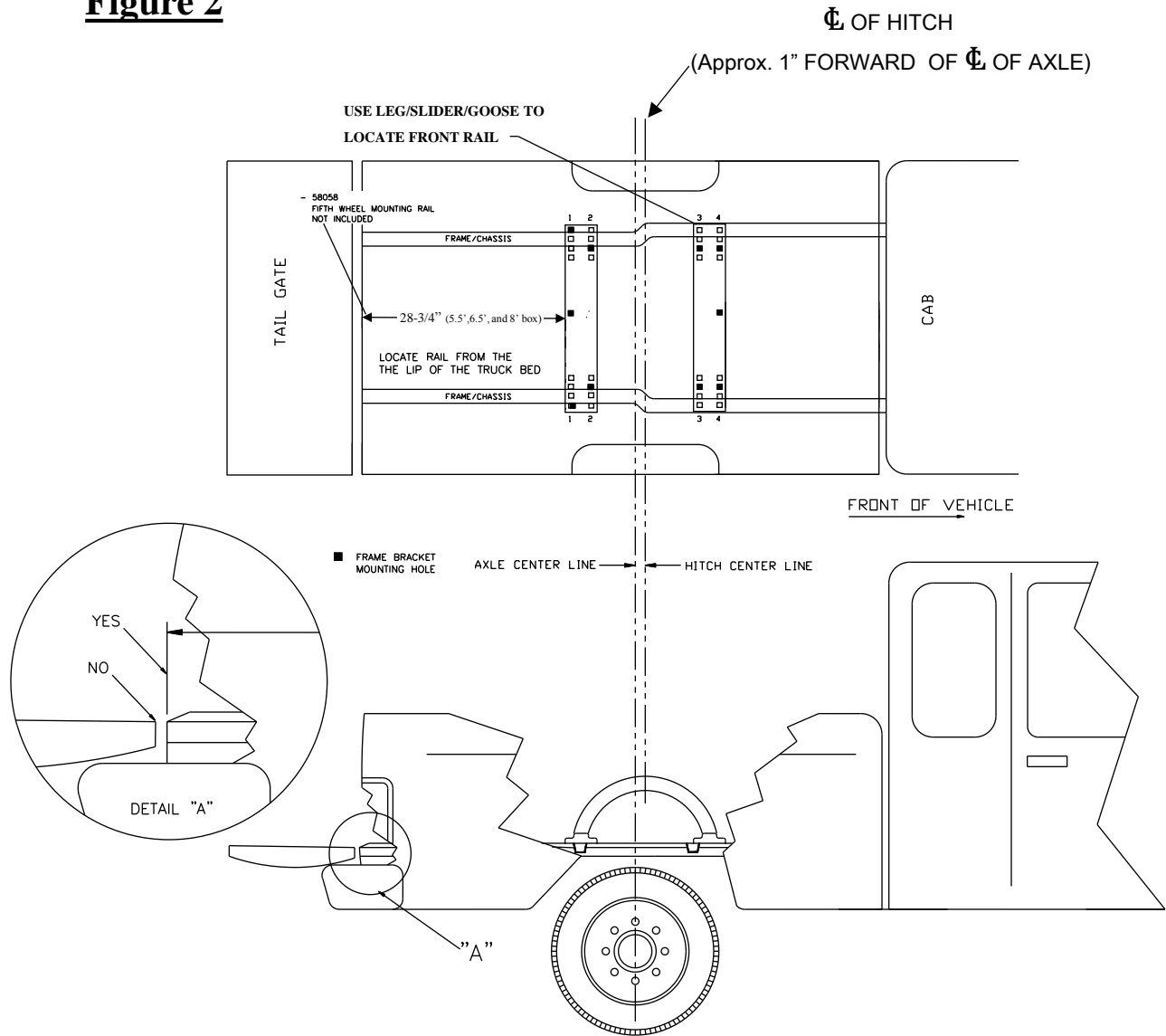

Figure 3 - Spacer Block Below Bed

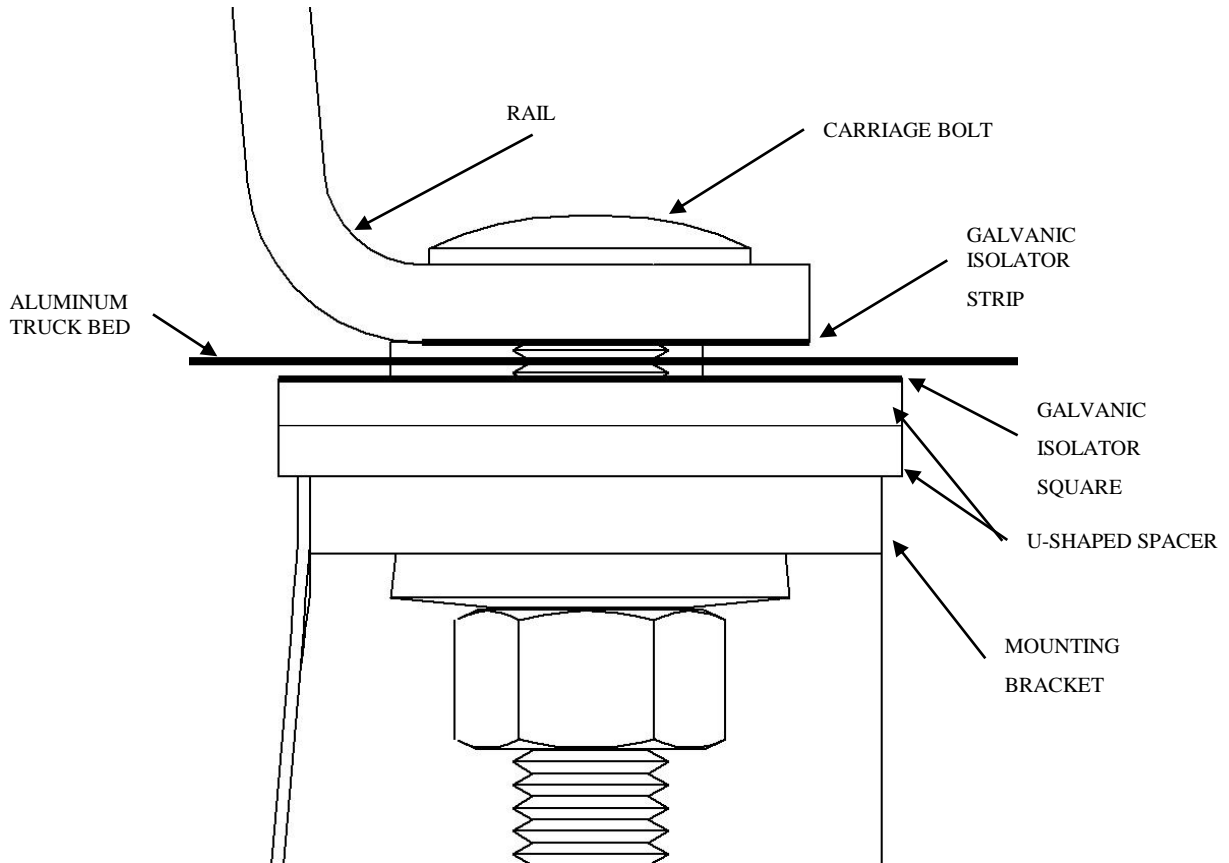

Figure 4 – Spacer Block Above Bed

