



TECHNICAL BULLETIN: TB15-03

Pro Series/Reese Select Series 5th Wheel: Service and Inspection Recommendation

Heavy Duty Towing

Pro Series / Reese Select 5th Wheel

- 16K Pro Series
- 20K Pro Series
- 16K Reese Select

Background: The upper handle C-clip may have been incorrectly installed to the handle during production. At low speeds, if a sequence of multipoint failure events occurs, the King Pin may become unlatched.

Service and Inspection

Inspection of Units in the original packaging: 16K Pro Series, 20K Pro Series and 16K Reese Select

- Inspection from a new packaged unit in a box: Only units with package dates between January 1, 2012 to August 15, 2014 are suspect. If suspect units are found, please perform the inspection described on Page 3 and Page 4.

Identification of Package Dates:

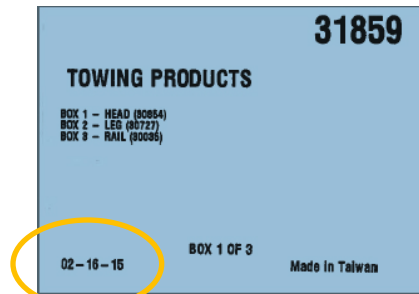

Date Code: Month-Date-Year
Example Feb 16, 2015

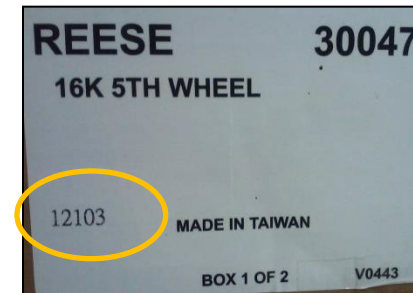

Date Code: YR/DDD
Example: 12103 = April 13, 2012



TECHNICAL BULLETIN: TB15-03

Pro Series/Reese Select Series 5th Wheel: Service and Inspection Recommendation

Service and Inspection

Inspection of Units in the field: 16K Pro Series, 20K Pro Series and 16K Reese Select

A. Units with MFG build date 2012 thru 2014 are suspect if they have:

- MFG Date Codes between M011201 – M011431
(Example 1201 is first week of Jan 2012)

AND

- The C-clip design shown here

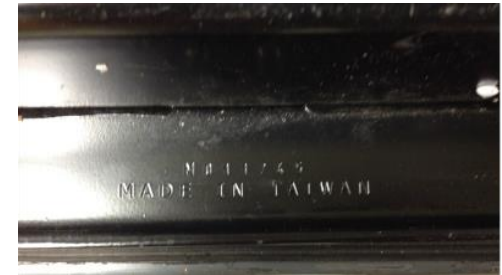

B. Units with MFG Date codes M011200 – M011431 are **OK** if they have either:

- A green dot or blue paint mark on the head assembly

OR

- The updated C-clip design





CEQUENT™
PERFORMANCE PRODUCTS



REESE

DRAW-TITE

RELA

FULTON

TEKONSHA

HIDDEN HITCH

PRO SERIES

WesBarg



TECHNICAL BULLETIN: TB15-03

Pro Series/Reese Select Series 5th Wheel: Service and Inspection Recommendation

- A. Remove the 5th Wheel Hitch – Head
- B. Lay on workbench upside down
- C. Inspect C-Clip to see if it is installed correctly at the handle to linkage joint (see page 4). *If installed correctly: the C-Clip will be at the prescribed location and will rotate by hand or screw driver force.*
- D. If the C-Clip is missing or not installed correctly, contact Reese for service kit 58526. Disconnect handle as identified below and install replacement C-Clip. **Warning: do not use or sell prior to replacing C-Clip!**
- E. Service Kit: C-Clips will have colored paint dot on clips.

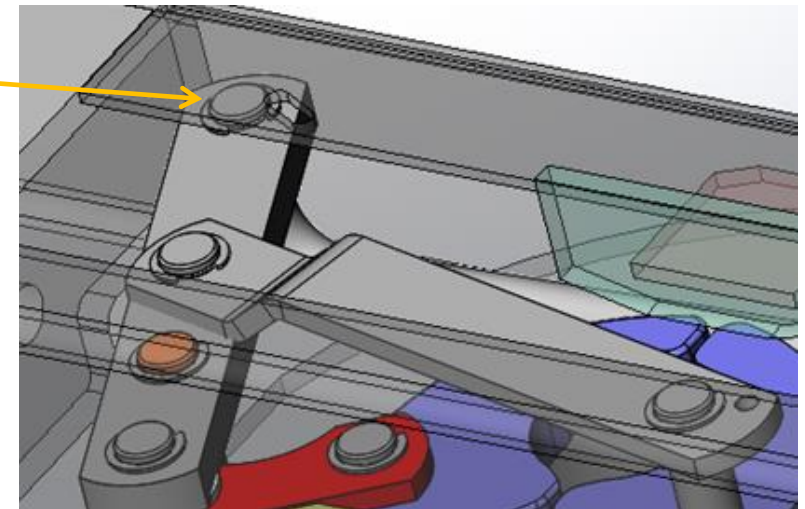
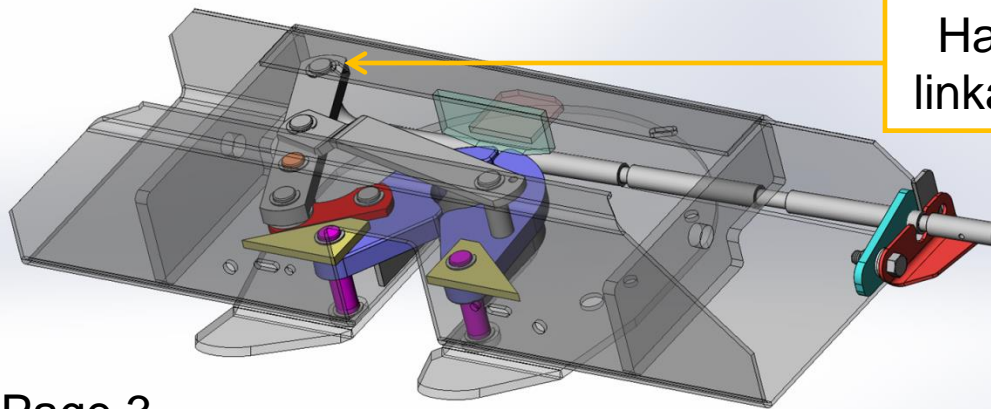
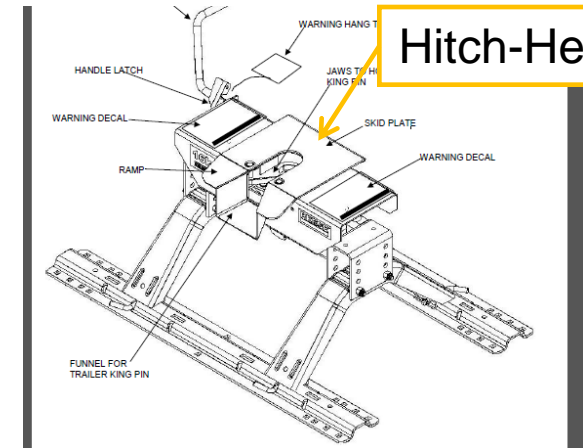



CEQUENT™
PERFORMANCE PRODUCTS



REESE



RELA

FULTON



HIDDEN HITCH

PRO
SERIES

WesBarg



TECHNICAL BULLETIN: TB15-03

Pro Series/Reese Select Series 5th Wheel: Service and Inspection Recommendation

Criteria for a correctly installed C-Clip:

A. C-Clip wings are in the groove



C-Clip Wings

B. C-Clip base is in the groove



C-Clip Base

C. Secondary verification:

Confirm that C-Clip rotates by hand or screw driver force.

