



Before Using Your Cargo Carrier

The user must read and understand these Instruction Sheets and the Warranty.

Installation is the end user's responsibility and beyond Cequent Consumer Products control. Therefore, Cequent Consumer Products exclusively limits its Warranty to the repair or replacement of a defective product. Damage to your vehicle, your cargo or any person or property is excluded.

- ⚠** Your Cargo Carrier must be inspected for signs of wear, corrosion and fatigue before each use.
- ⚠** Make sure your Cargo Carrier is secure before every trip. Check at each stop to ensure your Cargo Carrier is secure.
- ⚠** Remove your Cargo Carrier when not in use and before entering automatic car washes.
- ⚠** ALWAYS obey all posted speed limits and be aware of traffic conditions. Adapt your speed to the conditions of the road and the load being carried.
- ⚠** Check local and state laws governing projection of objects beyond the perimeter of a vehicle.
- ⚠** If Cargo Carrier or cargo is in line with exhaust pipe, an exhaust tip must be used to redirect the exhaust flow away.
- ⚠** Do not use your Cargo Carrier for purposes other than those for which it was designed.
- ⚠** Do not exceed your Cargo Carrier's weight capacity or your hitch tongue weight rating, whichever is lower. The capacity of your Cargo Carrier is 500 lb. (227 kg) with the 2" shank and 300 lb. (136 kg) with the 1-1/4" shank.
- ⚠** Position cargo so that the center of gravity is positioned in the middle third of the Cargo Carrier.
- ⚠** Your Cargo Carrier will not prevent property damage that may result from improper loading, securing, or driving.
- ⚠** Do not attempt to drill, weld, or modify your Cargo Carrier or any of the system components.

Review all Warnings, Instructions, and Warranty information carefully. Failure to follow these warnings and instructions will void the Warranty.



Parts List

Part	Description	Quantity
A	Hex Bolt, 1/4" x 3/4"	12
B	Carriage Bolt, 3/8" x 3"	2
C	Hex Bolt, 1/2" x 3"	1
D	Hex Lock Nut, 1/4"	12
E	Hex Lock Nut, 1/2"	1
F	Hex Nut, 3/8"	2
G	Flat Washer, 1/4"	24
H	Flat Washer, 1/2"	2
I	Flat Washer, 3/8"	2
J	Hitch Pin, 5/8" (Not Shown)	1
K	Hitch Pin, 1/2"	1
L	Clip	2
M	End Plate	1
N	End Plate w/ Shank hole	1
O	Center Plate	1
P	Shank	1
Q	Adaptor	1
R	Basket Frame	2
S	Reflective Tape (Not Shown)	2

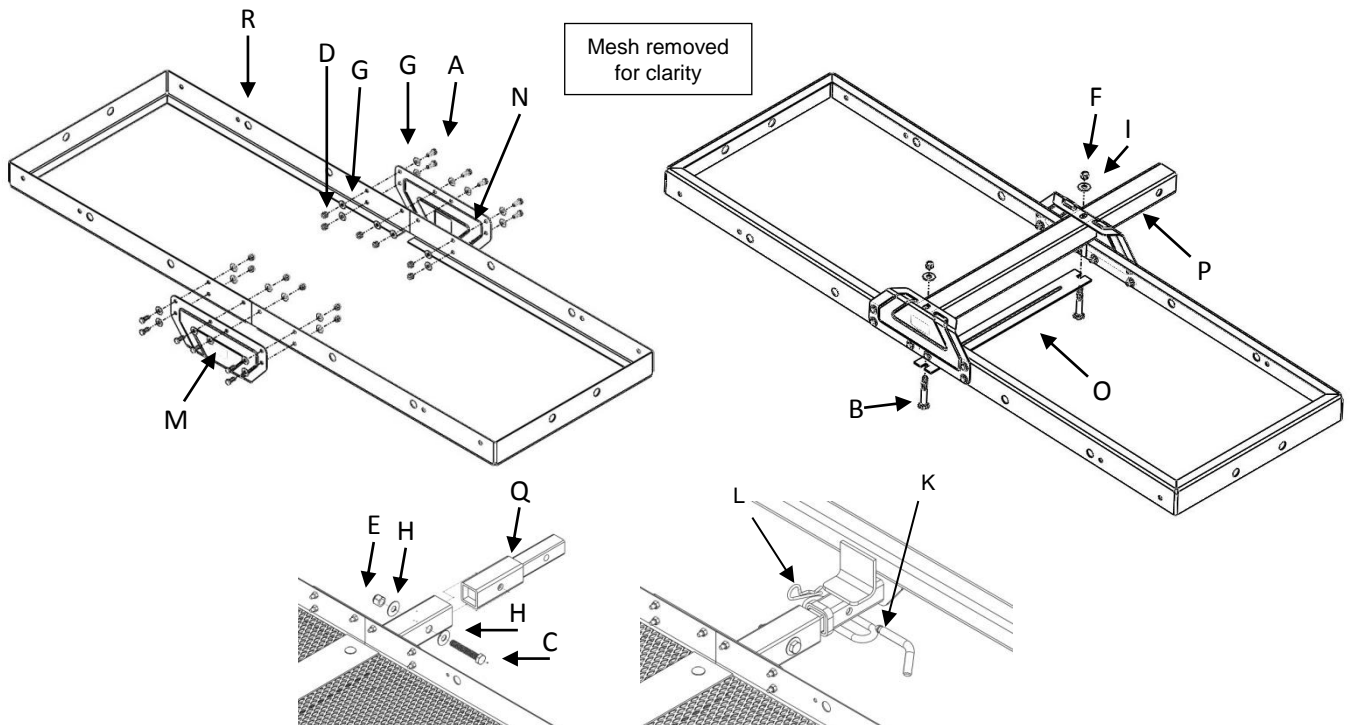

Installation Instructions

Tools required for assembly: 7/16" Wrench, 7/16" Socket, 9/16" Wrench

Step 1: Remove all parts from box and make sure all parts out of the box are undamaged.

Step 2: Assemble Cargo Carrier

- Align both halves of the basket on the ground. Attach each end plate to the outside of the basket as shown in Fig 1 and fasten loosely with (12) 1/4" bolts, (24) 1/4" flat washers, and (12) 1/4" hex nuts.
- Slide 2" shank through shank hole and align holes in end plates. Align center plate on the inside of the basket with holes in shank and loosely attach with (2) 3/8" carriage bolts, (2) 3/8" flat washers, and (2) 3/8" nuts.
- Go back and tighten all hardware. Tighten all 1/4" hex bolts to 6 ft-lb and all 3/8" bolts to 24 ft-lb.

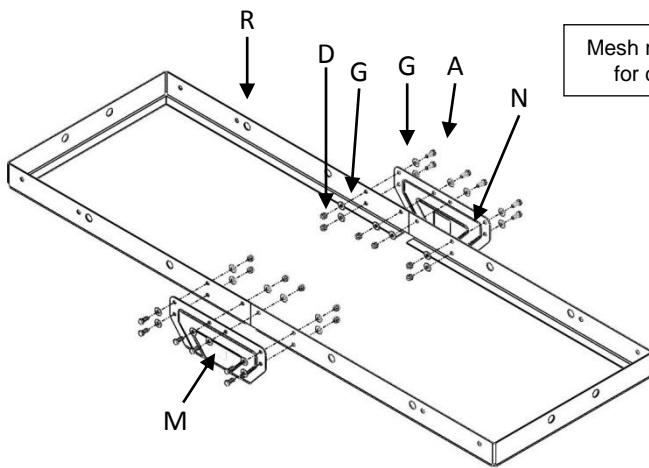

Fig 1

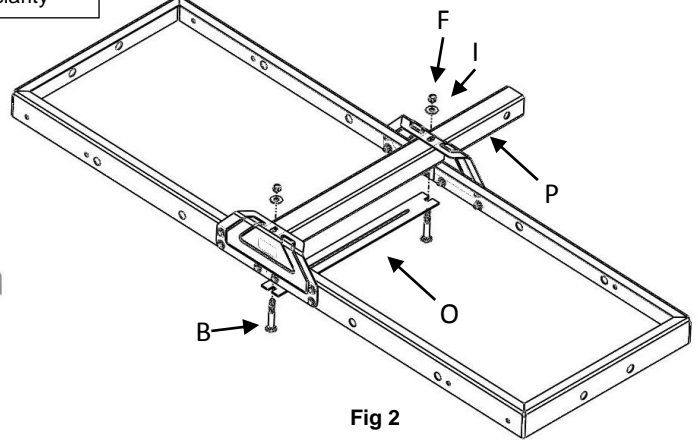

Fig 2

Step 3: Install Cargo Carrier to Hitch

- For 2" hitches, slide Cargo Carrier shank into hitch so that hitch holes and shank holes are aligned. Insert 5/8" hitch pin through hole and secure with clip. (Fig 3)
- For 1-1/4" hitches, insert adapter into shank so that the through holes are aligned. Secure with 1/2"x3" hex bolt, (2) 1/2" flat washer and 1/2" hex nut. Tighten to 24 ft-lb. (Fig 4)
- Slide Cargo Carrier adapter into hitch so that hitch holes and adapter hole is aligned. Insert 1/2" hitch pin and secure with clip (Fig 5)

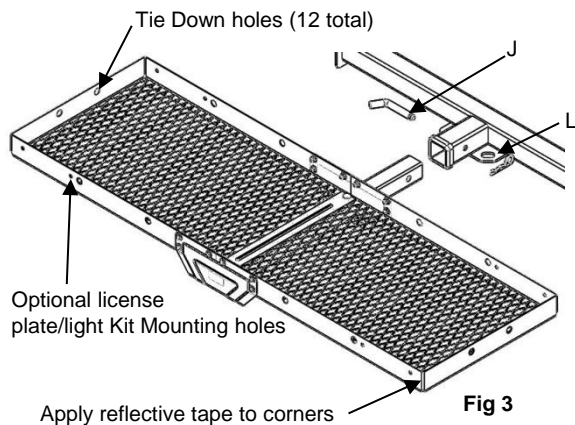

Fig 3

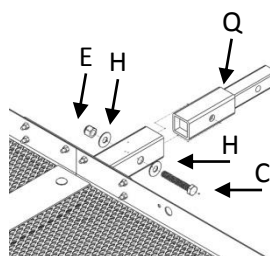

Fig 4

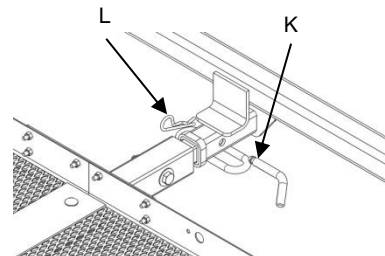

Fig 5

Before Driving

⚠️ WARNING

To Prevent Serious Injury or Death:

- **INSPECT** for signs of wear, corrosion, and fatigue **BEFORE** each use. **DO NOT** use if bent or deformed.
- **Do not exceed your Cargo Carrier's weight capacity or your hitch tongue weight rating, whichever is lower. The capacity of your Cargo Carrier is 500 lb. (227 kg) with the 2" shank and 300 lb. (136 kg) with the 1-1/4" shank.**
- **DO NOT use Cargo Carrier to transport people, animals, or flammable liquids.**

Check local and state laws governing projection of objects beyond the perimeter of a vehicle. Be aware of the width and height of your cargo since low clearance branches, bridges, and parking garages can affect the load.

1. Lift the cargo onto the Cargo Carrier. Place heavy, large objects on first and evenly distribute the weight so that the center of gravity is within the middle third of the platform.
2. Secure the cargo to the Cargo Carrier. Make sure all bolts, straps, knobs and locks are firmly attached and locked before every trip.

⚠️ NEVER use elastic straps or belts to secure cargo.

3. **CHECK BOTH THE CARGO AND THE Cargo Carrier ARE SECURE.**

⚠️ If your Cargo Carrier is not secure, DO NOT use your Cargo Carrier. Remember cargo can shift or the Cargo Carrier can loosen during travel. Readjust as needed. If movement continues, stop use.

While Driving

⚠️ WARNING

To Prevent Serious Injury, Death and Property Damage:

- **REDUCE YOUR SPEED.** Your vehicle can handle differently when transporting cargo.
- **ALWAYS** obey all posted speed limits and be aware of traffic conditions.
- **FREQUENTLY** check your Cargo Carrier and the cargo is secure. Cargo can shift or your Cargo Carrier can loosen during travel. Readjust as needed. If movement continues, stop use.
- **ALWAYS** use caution when opening hatch when using your Cargo Carrier to transport cargo to prevent damage to vehicle.

After Driving

⚠️WARNING

To Prevent Serious Injury and Property Damage:

- **ALWAYS** unload all objects before removing your Cargo Carrier from hitch.
- **ALWAYS** remove your Cargo Carrier when not in use.

Removing your Cargo Carrier when not in use may also reduce fuel consumption.

THIS WARNING IS GIVEN IN COMPLIANCE WITH CALIFORNIA PROPOSITION 65

WARNING: This product contains chemicals known to the state of California to cause cancer, birth defects or other reproductive harm.

The proper attachment of this product in accordance with the enclosed instructions is critical to its proper performance. Cequent Consumer Products, Inc. has no control over, or responsibility for, the attachment or the installation. Cequent Consumer Products, Inc. is NOT responsible nor will be held liable for any damage resulting from its attachment or improper use. Cequent Consumer Products, Inc. shall not be liable for any claims of any kind greater than the purchase price of the product.