

Installation Instructions

Part Numbers:

Ford Econoline Van

41945

96945

All Models

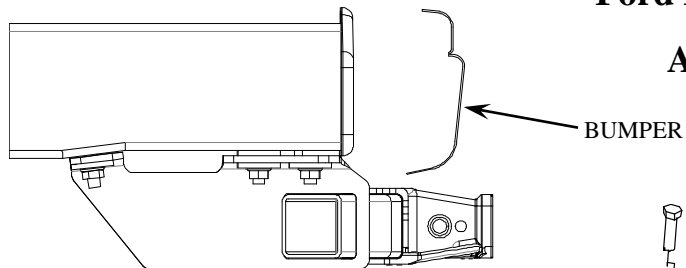

BUMPER

Do Not Exceed Lower of Towing Vehicle
Manufacturer's Rating or

Hitch type	Max Gross Trailer WT (LB)	Max Tongue WT (LB)
Weight Distributing	12000 (5448 Kg)	1200 (545 Kg)
Weight Carrying Ball Mount	10000 (4540 Kg)	1500 (681 Kg)

Hitch Shown In Proper Position

Equipment Required:

Fastener Kit: 41945F

Wrenches: 13/16", 7/8"

Drill Bits: NONE

Wiring Access Location: SUV1, SUV2

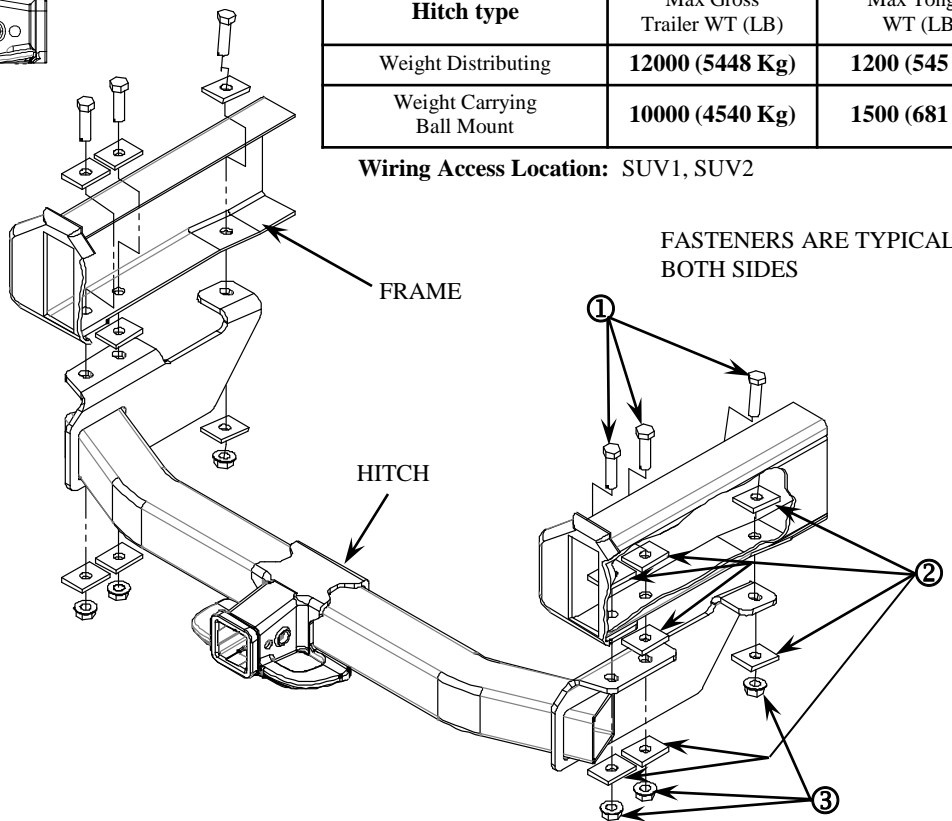

①	Qty. (6)	BOLT- HEX HEAD 9/16-18 X 2.00 GR5	③	Qty. (6)	LOCKNUT – FLANGED 9/16-18
②	Qty. (14)	BLOCK – 1.50 X 2.00 X .250			

- IF PRESENT, LOWER CARBON CANISTER FROM DRIVER'S SIDE FRAME RAIL.
- DISCONNECT FROM BUMPER, FACTORY INSTALLED OPTIONAL DRIVER'S SIDE TRAILER WIRING CONNECTOR.
- RAISE HITCH INTO POSITION AND ATTACH WITH FASTENERS AS SHOWN ABOVE.
MAKE SURE TO SANDWICH A BLOCK BETWEEN HITCH AND FRAME AT MIDDLE ATTACHMENT.
- REINSTALL FACTORY TRAILER WIRING CONNECTOR TO CLEAR HITCH
- REATTACH CARBON CANISTER IF PRESENT – CARBON CANISTER MUST NOT CONTACT BOLT HEAD, IF IT DOES, LOOSEN CANISTER FASTENERS AND REPOSITION TO ENSURE CLEARANCE WITH BOLT HEAD.

Tighten all 9/16-18 grade 5 fasteners with torque wrench to 120 Lb.-Ft. (163 n*m)

Note: check hitch frequently, making sure all fasteners and ball are properly tightened. If hitch is removed, plug all holes in trunk pan or other body panels to prevent entry of water and exhaust fumes. A hitch or ball which has been damaged should be removed and replaced. Observe safety precautions when working beneath a vehicle and wear eye protection. Do not cut access or attachment holes with a torch.

This product complies with safety specifications and requirements for connecting devices and towing systems of the state of New York, V.E.S.C. Regulation V-5 and SAE J684.