

Installation Instructions

C & K Series Full Size Pickup w/8' Box Chevrolet & GMC Cab & Chassis* Ford 350 Super Duty Cab & Chassis*

Part Numbers:

41938

96938

*-Vehicles with 34" Frame Spacing

Note: Vehicle **MUST** have a minimum of 19" from end of frame rail to spring shackle bracket

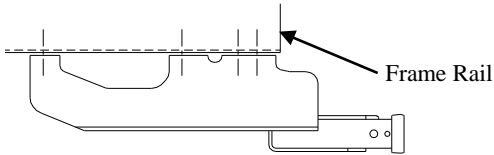

**Do Not Exceed Lower of Towing Vehicle
Manufacturer's Rating or**

Hitch type	Max Gross Trailer WT (LB)	Max Tongue WT (LB)
Weight Distributing	15,000 (6 810 Kg)	1,500 (681 Kg)
Weight Carrying Ball Mount	12,000 (5 448 Kg)	1,200 (545 Kg)

Hitch Shown In Proper Position

Equipment Required:

Fastener Kit: 41938F

Wrenches: 13/16", 7/8"

Drill Bits: 9/16"

Wiring Access Location: PU3

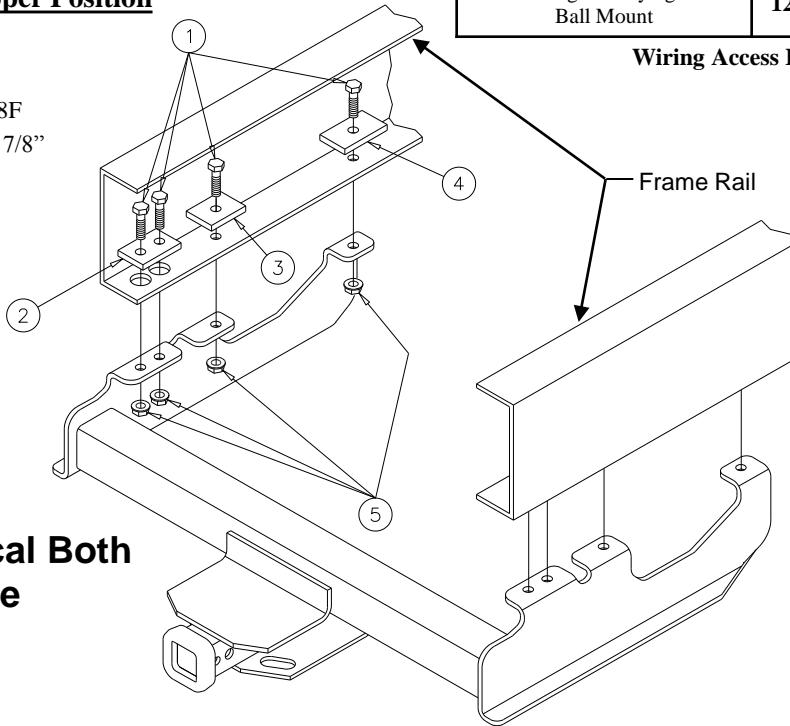

Fasteners Typical Both Sides of Vehicle

①	Qty. (8)	Hex Bolt 9/16-18 x 1-3/4" GR5	④	Qty. (2)	Spacer 3/8 x 1-1/2 x 3" (Single Hole)
②	Qty. (2)	Spacer 3/8 x 1-1/2 x 3" (2 Holes)	⑤	Qty. (8)	Flanged Locknut 9/16-18
③	Qty. (2)	Spacer 3/8 x 1-1/2 x 2"			

Warning: Under no circumstances is this hitch to be installed on a vehicle with 6' box (short wheelbase)

Note: 1981 and later models with factory step bumpers require removal of support brackets to frame. These brackets should be retained for replacement upon removal of the hitch. The step bumper should not be used for towing with the brackets removed.

1. Remove the spare tire and carrier from the vehicle. If the under-box tire storage is to be retained, the spare tire carrier will have to be relocated and/or modified after receiver is installed.
2. Position the receiver on the vehicle with the rear attaching holes aligned with the slots in the end of the frame.
3. Center the receiver on the frame. Using the receiver as a template, drill and/or enlarge the remaining holes.
4. Install all fasteners as shown, placing the blocks inside the frame rails.

Tighten all 9/16-18 GR5 fasteners with torque wrench to 110 Lb.-Ft. (149 N-M)

Note: check hitch frequently, making sure all fasteners and ball are properly tightened. If hitch is removed, plug all holes in trunk pan or other body panels to prevent entry of water and exhaust fumes. A hitch or ball which has been damaged should be removed and replaced. Observe safety precautions when working beneath a vehicle and wear eye protection. Do not cut access or attachment holes with a torch.

This product complies with safety specifications and requirements for connecting devices and towing systems of the state of New York, V.E.S.C. Regulation V-5 and SAE J684.