

INSTALLATION INSTRUCTIONS

EQUIPMENT REQUIRED:

WIRING ACCESS LOCATION: PU3

DRILL BITS: 1/2

WRENCHES: (TIGHTEN ALL FASTENERS WITH TORQUE WRENCH) 7/8 (CROWFOOT)

VEHICLE	HITCH NO.
CHEVROLET/GMC PICK-UP ALL REGULAR & EXTENDED MODELS WITH AFTERMARKET ROLL PAN EXCEPT 2500 SERIES WITH H.D SUSPENSION OR ANY 3500 SERIES SEE DIAGRAM 1	41522

- * WILL NOT FIT VEHICLES W
- * IF UNDER BED SPARE TIRE IS TO BE RETAINED, AN AFTERMARKET SPARE TIRE REPOSITIONER WILL HAVE TO BE INSTALLED.
- * LICENSE PLATE MUST BE REPOSITIONED WHILE DRAWBAR IS IN USE.

ROLL PAN CUTTING REQUIRED. OBTAIN VEHICLE OWNER APPROVAL BEFORE CUTTING.

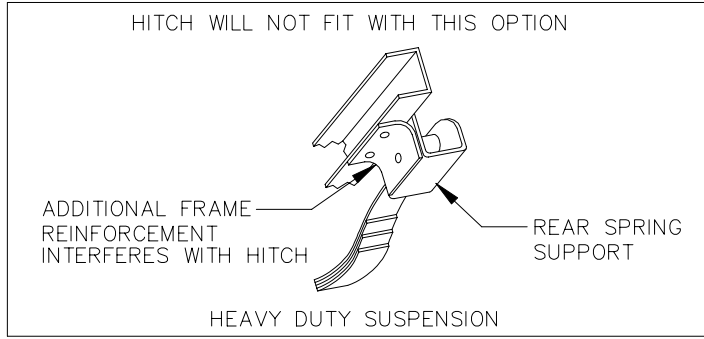

DIAGRAM 1

DO NOT EXCEED LOWER OF TOWING VEHICLE MFR'S RATINGS OR

HITCH TYPE ▼	MAX GROSS TRLR WT(LB)	MAX TONGUE WT(LB)
WEIGHT DISTRIBUTING	5500	550
WEIGHT CARRYING BALL MOUNT	5000	500

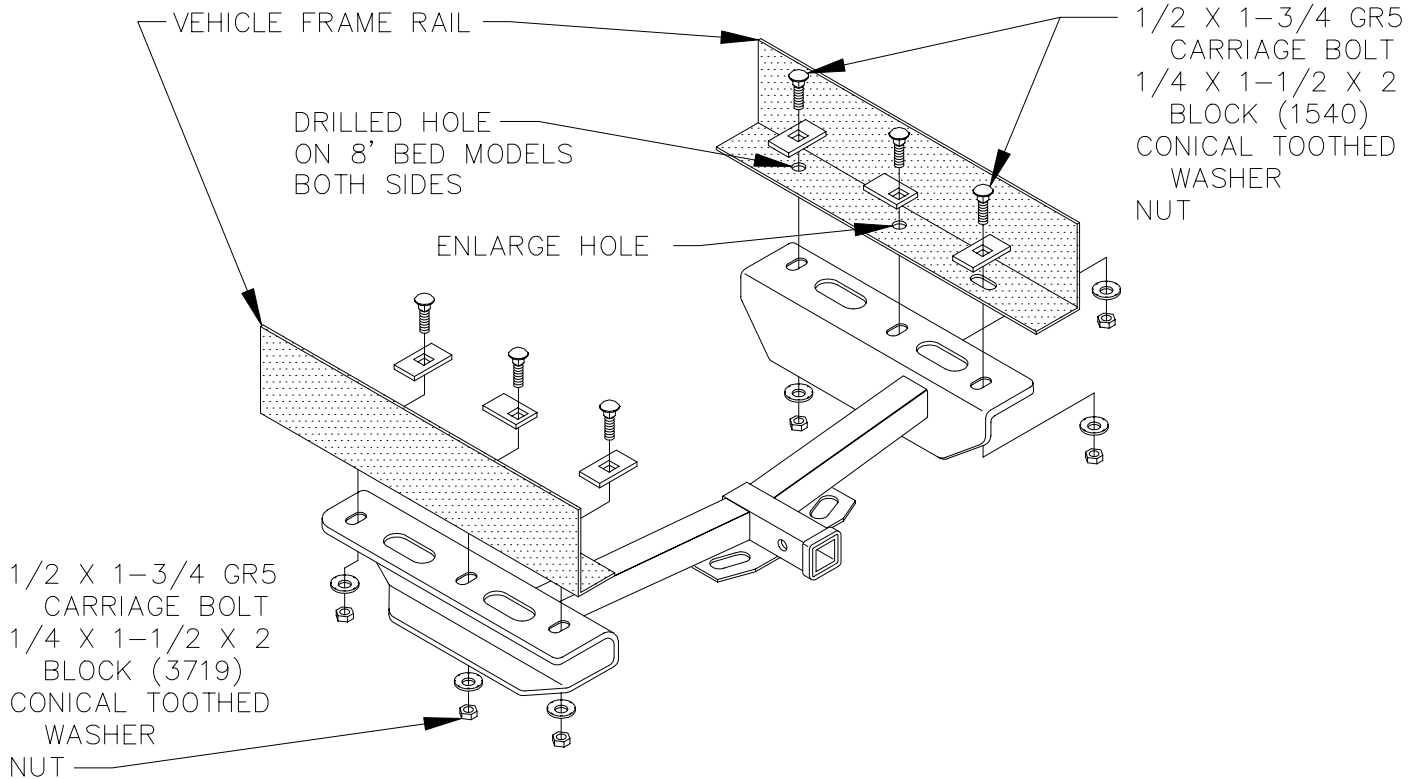

FIGURE 1.

THIS PRODUCT COMPLIES WITH SAFETY SPECIFICATIONS AND REQUIREMENTS FOR CONNECTING DEVICES AND TOWING SYSTEMS OF THE STATE OF NEW YORK AND V.E.S.C. REGULATION V-5.

APPROX WEIGHT (LB.)	27	FASTENER KIT NO.	K41522
---------------------	----	------------------	--------

NOTE: Check hitch frequently, making sure all fasteners and ball are properly tightened. If hitch is removed, plug all holes in trunk pan or other body panels to prevent entry of water and exhaust fumes. A hitch or ball which has been damaged should be removed and replaced. Observe safety precautions when working beneath a vehicle and wear eye protection. Follow car maker's specs for maximum trailer weight and tongue weight. Do not cut access or attachment holes with a torch.

VEHICLE	HITCH NO.
CHEVROLET/GMC PICK-UP ALL REGULAR & EXTENDED MODELS WITH AFTERMARKET ROLL PAN EXCEPT 2500 SERIES WITH H.D SUSPENSION OR ANY 3500 SERIES SEE DIAGRAM 1	41522

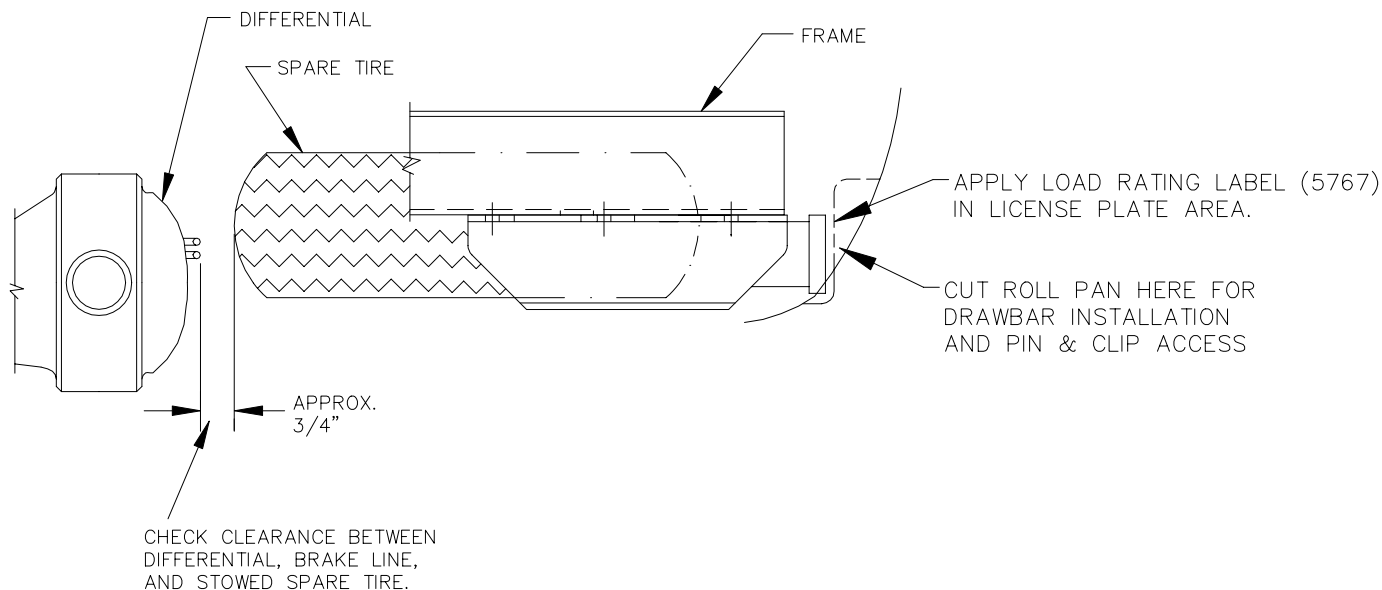

HITCH SHOWN IN PROPER POSITION
(SPARE SHOWN WITH AFTERMARKET REPOSITIONER)
FIGURE 2.

1. REMOVE SPARE TIRE. IF UNDER BED SPARE TIRE IS TO BE RETAINED, AN AFTERMARKET SPARE TIRE REPOSITIONER WILL HAVE TO BE INSTALLED.
2. POSITION REARMOIST SLOTS IN RECEIVER OVER FORE/AFT SLOT NEAR END OF FRAME.
NOTE: ON 8' BED MODELS, USING HITCH AS A TEMPLATE, DRILL FORWARD ATTACHMENT HOLES.
3. INSTALL FASTENERS AS SHOWN. SEE FIGURE 1.
NOTE: 1/4 X 1-1/2 X 2 BLOCKS (1540 AND 3719) MUST BE ORIENTED AS SHOWN.
4. CUT ROLL PAN IN LICENSE PLATE AREA TO PROVIDE DRAWBAR INSTALLATION AND PIN & CLIP ACCESS.
NOTE: LICENSE PLATE MUST BE REPOSITIONED WHILE DRAWBAR IS IN USE.
5. IF ROLL PAN LIP CONTACTS HITCH SIDE BRACKETS, TRIM ROLL PAN AS NECESSARY.
6. APPLY LOAD RATING LABEL (5767) PROVIDED IN LICENSE PLATE AREA OF ROLL PAN.
7. WHEN USING AN AFTERMARKET SPARE TIRE REPOSITIONER, CHECK CLEARANCE BETWEEN SPARE TIRE, BRAKE LINES AND DIFFERENTIAL. SEE FIGURE 2.

TIGHTEN 1/2 GR5 FASTENERS TO 75 LB.-FT.

THIS PRODUCT COMPLIES WITH SAFETY SPECIFICATIONS AND REQUIREMENTS FOR CONNECTING DEVICES AND TOWING SYSTEMS OF THE STATE OF NEW YORK AND V.E.S.C. REGULATION V-5.

APPROX WEIGHT (LB.)	FASTENER KIT NO.
---------------------	------------------

NOTE: Check hitch frequently, making sure all fasteners and ball are properly tightened. If hitch is removed, plug all holes in trunk pan or other body panels to prevent entry of water and exhaust fumes. A hitch or ball which has been damaged should be removed and replaced. Observe safety precautions when working beneath a vehicle and wear eye protection. Follow car maker's specs for maximum trailer weight and tongue weight. Do not cut access or attachment holes with a torch.

®