



Installation Instructions

PART NUMBERS: 76034, 84034

⚠ WARNING

To prevent **SERIOUS INJURY, DEATH or PROPERTY DAMAGE:**

- **ALWAYS read, understand and follow warnings and instructions for your hitch BEFORE installation. Keep for future reference.**
 - **DO NOT cut, weld or modify this receiver.**
 - **CHECK all fasteners are tight and your hitch is securely mounted to your vehicle periodically.**
 - **ALWAYS read, understand and follow all warnings and instructions for your vehicle and for other accessories you will use with your hitch BEFORE use.**
 - **LOAD the trailer heavier in front.**
 - **DO NOT exceed lower of towing vehicle manufacturer’s rating or:**
- | Hitch Type | Max Gross Trailer Weight | Max Tongue Weight |
|---------------------|--------------------------|-------------------|
| Weight Carrying | 4500 lb. (2043 kg) | 675 lb. (306 kg) |
| Weight Distributing | 5000 lb. (2270 kg) | 500 lb. (227 kg) |
- **ALWAYS wear your seatbelt.**
 - **SLOW DOWN when towing, NEVER exceed any posted speed limit.**
 - **If EXCESS SWAY occurs, take your foot off the gas pedal and hold the steering wheel as steady as possible. DO NOT apply your brakes and DO NOT speed up.**

LIMITED LIFETIME WARRANTY

1. **Limited Lifetime Warranty (“Warranty”).** Cequent Performance Products, Inc. (“We”, “Us” or “Our”) warrants to the original consumer purchaser only (“You” or “Your”) that the product will be free from material defects in both material and workmanship, ordinary wear and tear excepted. The Warranty is valid only if (a) the products are returned to Us for inspection and testing; (b) Our inspection discloses to Our satisfaction that any alleged nonconformance are material and have not been caused by misuse, neglect, wear and tear, improper installation, unsuitable storage, improper repair, alteration, or accident; and (c) the products were installed, maintained and used in accordance with Our instructions. **THE WARRANTY IS MADE IN LIEU OF ALL OTHER WARRANTIES, EXPRESS OR IMPLIED (OTHER THAN THE WARRANTY OF TITLE AS PROVIDED BY THE UNIFORM COMMERCIAL CODE IN EFFECT IN MICHIGAN), INCLUDING WITHOUT LIMITATION, ANY WARRANTIES OF MERCHANTABILITY OR FITNESS FOR A PARTICULAR PURPOSE, SAID WARRANTIES BEING EXPRESSLY DISCLAIMED.**
2. **Obligations of Purchaser.** Any returned product that is replaced by Us becomes our property. You may be responsible for return shipping costs. Please retain your purchase receipt to verify date of purchase and that You are the original consumer purchaser. The product and the purchase receipt must be provided to Us in order to process Your Warranty claim.
3. **Exclusive Remedy.** Product replacement is Your sole and exclusive remedy under this Warranty. We shall not be liable for service or labor charges incurred in removing or replacing a product. **IN NO EVENT WILL WE BE RESPONSIBLE FOR ANY INDIRECT, SPECIAL, CONSEQUENTIAL OR PUNITIVE DAMAGES.**
4. **Assumption of Risk.** You acknowledge and agree that any use of the product for any purpose other than the specified use(s) stated in the product instructions is at Your own risk.
5. **Governing Law.** This Warranty gives You specific legal rights, and You also may have other rights which vary from state to state. This Warranty is governed by the laws of the State of Michigan, without regard to rules pertaining to conflicts of law. The state courts located in Oakland County, Michigan shall have exclusive jurisdiction for any disputes relating to this Warranty.



Installation Instructions

PART NUMBERS: 76034, 84034

Applications:

Years	Make	Models
-------	------	--------

2011-Current*	Ford	Explorer
---------------	------	----------

*Visit our website for the most up to date information regarding application years and trim levels.









Installation Time: 45 Min.

The time listed above is the average time for professional installers. If you do not feel comfortable performing this installation on your own or are in need of assistance, please contact a professional installer.

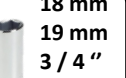

Representative Vehicle Photo

Equipment Required:

 Safety Glasses	 Ratchet	 18 mm 19 mm 3 / 4 " 11/16"	 Torque Wrench	 Optional Universal Joint Socket
 Lubricant or Soapy water	 6" socket Extension	 Pry Bar	 or Exhaust Removal Pliers	

DO NOT EXCEED LOWER OF TOWING VEHICLE MANUFACTURER'S RATING OR:

Hitch Type	Max Gross Trailer Weight	Max Tongue Weight
Weight Carrying	4500 lb. (2043 kg)	675 lb. (306 kg)
Weight Distributing	5000 lb. (2270 kg)	500 lb. (227 kg)

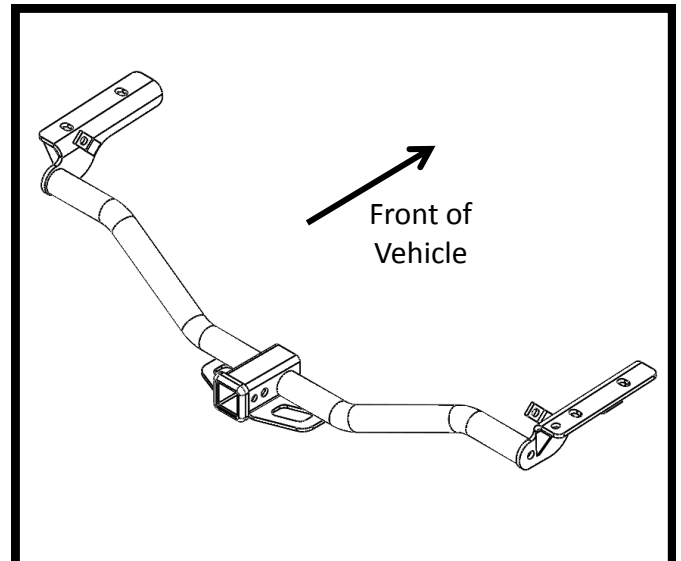

Hitch Illustration



Always wear **SAFETY GLASSES** when installing hitch

Installation Instructions

PART NUMBERS: 76034, 84034

Fastener Kit : 76034F

①	Qty. (4)	Hex bolt M12 x 1.75 40mm CL8.8	
②	Qty. (5)	Conical washer 1/2"	
③	Qty. (1)	Bolt Carriage 1/2-13 x 1.50 GR5	
④	Qty. (1)	Spacer 1/4" x 1.00 x 2.00	
⑤	Qty. (1)	Hex nut 1/2-13	
⑥	Qty. (2)	Bolt carriage 7/16-14 x 2.500 GR5	
⑦	Qty. (2)	Flat washer 7/16"	
⑧	Qty. (2)	Hex lock nut 7/16-14	
⑨	Qty. (1)	Pull wire 1/2-13	

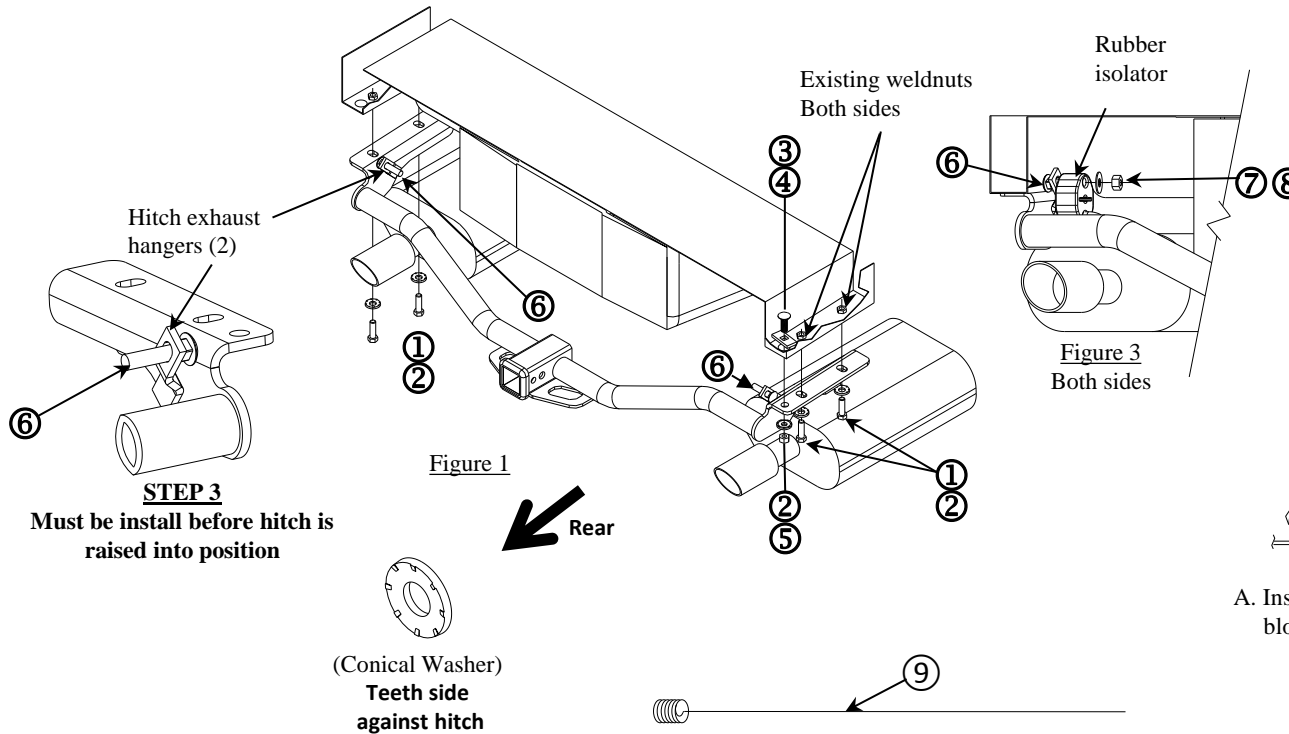

For vehicles with OEM Tow Hook: Tow hook must be permanently removed for hitch installation.

- Lower exhaust system at the rubber isolator (3 places). Note: Spraying a lubricant or soapy water on the metal hanger rod and the rubber isolator helps removal. Remove rubber isolator from mufflers only (2) to be re-install step 3. Be careful not to allow muffler to fall under its own weight.
- Remove and return exhaust hanger, and/or exhaust hanger with factory tow hook, and fasteners to vehicle owner.
- Install carriage bolts (item 6) into exhaust hangers on hitch. Install rubber isolators removed in step 1, onto 7/16 carriage bolts on hitch. Install flat washer, and 7/16-14 hex lock nut. See Figure 3.
- Feed 1/2-13 carriage bolt and spacer into passenger side frame rail as shown using reverse pullwire procedure. Leave pullwire attached. See Figure 2.
- Feed pull wire through hole in bracket on passenger side. Raise hitch into position, over exhaust and align with existing weldnuts in frame rail and 1/2-13 carriage bolt installed in Step 4. Install M12 hex bolts and conical washer as shown.
- Remove pullwire and install conical washer and hex nut on carriage bolt.
- Tighten all M12 CL8.8 fasteners with torque wrench to 68 Lb.-Ft (92 N*M), Tighten all 1/2-13 GR5 fasteners with torque wrench to 75 Lb.-Ft. (102 N*M)**
Proper torque is needed to keep the hitch secure to the vehicle when towing.
- Raise exhaust back into position (3 places). Note: Spraying a lubricant or soapy water on the metal hanger rod and the rubber isolator helps.

Note: check hitch frequently, making sure all fasteners and ball are properly tightened. If hitch is removed, plug all holes in trunk pan or other body panels to prevent entry of water and exhaust fumes. A hitch or ball which has been damaged should be removed and replaced. Observe safety precautions when working beneath a vehicle and wear eye protection. Do not cut access or attachment holes with a torch.

This product complies with safety specifications and requirements for connecting devices and towing systems of the state of New York, V.E.S.C. Regulation V-5 and SAE J684.

For vehicles with OEM Tow Hook: Tow hook must be permanently removed for hitch installation.

1. Lower exhaust system at the rubber isolator (3 places). Note: Spraying a lubricant or soapy water on the metal hanger rod and the rubber isolator helps removal. Remove rubber isolator from mufflers only (2) to be re-install step 3. **Be careful not to allow muffler to fall under its own weight.**

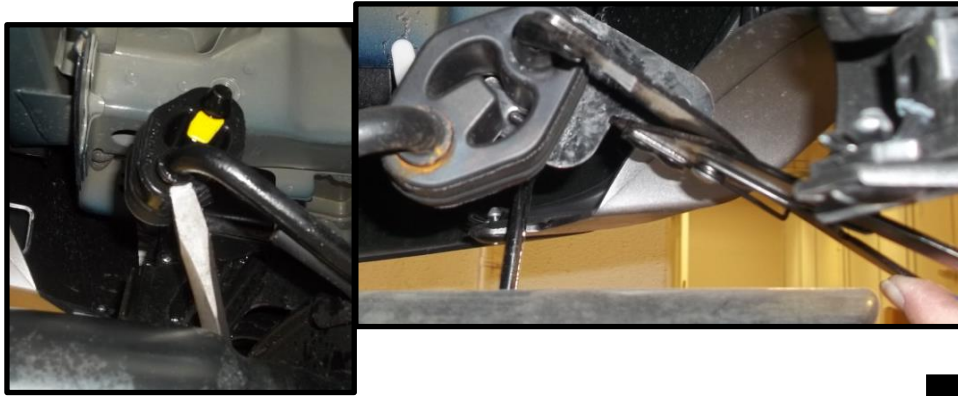

2. Remove and return exhaust hanger, and/or exhaust hanger with factory tow hook, and fasteners to vehicle owner.

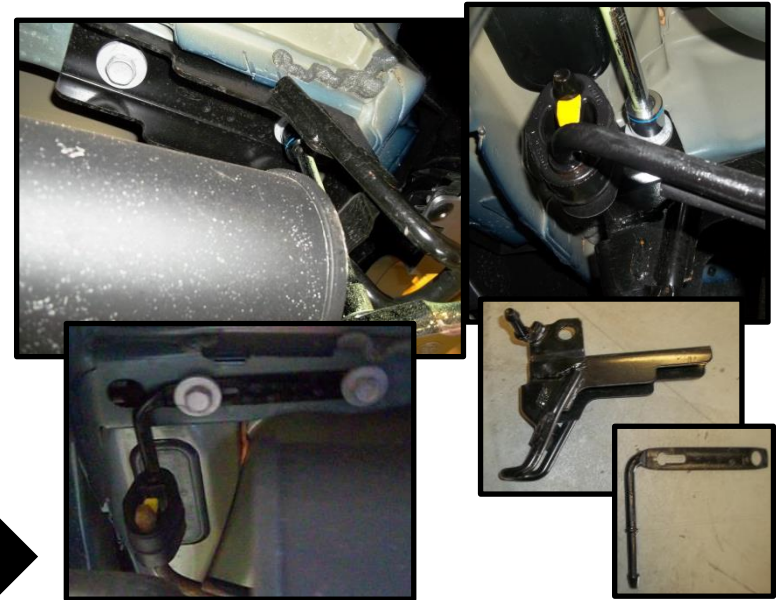

3. Install carriage bolts (item 6) into exhaust hangers on hitch. Install rubber isolators removed in step 1, onto 7/16 carriage bolts on hitch. Install flat washer, and 7/16-14 hex lock nut. See Figure 3.



4. Feed ½-13 carriage bolt and spacer into passenger side frame rail as shown using reverse pullwire procedure. Leave pullwire attached. See Figure 2.

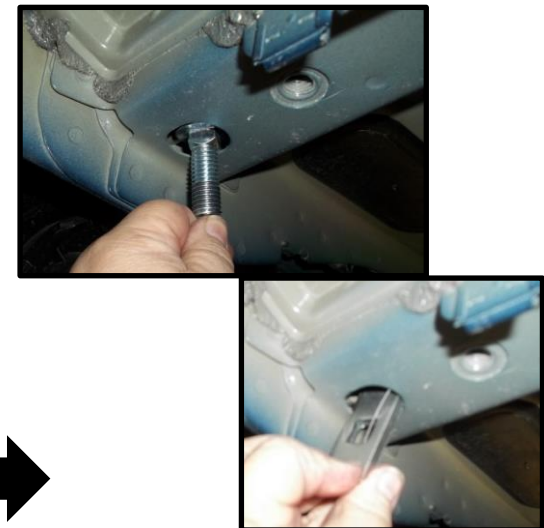

5. Feed pull wire through hole in bracket on passenger side. Raise hitch into position, over exhaust and align with existing weldnuts in frame rail and 1/2-13 carriage bolt installed in Step 4. Install M12 hex bolts and conical washer as shown.



6. Remove pullwire and install conical washer and hex nut on carriage bolt.



7. **Tighten all M12 CL.8.8 fasteners with torque wrench to 68 Lb.-Ft (92 N*M) , Tighten all 1/2-13 GR5 fasteners with torque wrench to 75 Lb.-Ft. (102 N*M)**

⚠ Proper torque is needed to keep the hitch secure to the vehicle when towing.



8. Raise exhaust back into position (3 places). Note: Spraying a lubricant or soapy water on the metal hanger rod and the rubber isolator helps

