



# Installation Instructions

PART NUMBERS: 76016, 84016, CQT76016

## LIMITED LIFETIME WARRANTY

### ⚠ WARNING

To prevent **SERIOUS INJURY, DEATH** or **PROPERTY DAMAGE**:

- **ALWAYS** read, understand and follow warnings and instructions for your hitch **BEFORE** installation. Keep for future reference.
- **DO NOT** cut, weld or modify this receiver.
- **CHECK** all fasteners are tight and your hitch is securely mounted to your vehicle periodically.
- **ALWAYS** read, understand and follow all warnings and instructions for your vehicle and for other accessories you will use with your hitch **BEFORE** use.
- **LOAD** the trailer heavier in front.
- **DO NOT** exceed lower of towing vehicle manufacturer's rating or:

Hitch Type	Max Gross Trailer Weight	Max Tongue Weight
Weight Carrying	6000 lb. (2722 kg)	900 lb. (408 kg)
Weight Distributing	10000 lb. (4536 kg)	1000 lb. (454 kg)

- **ALWAYS** wear your seatbelt.
- **SLOW DOWN** when towing, **NEVER** exceed any posted speed limit.
- If **EXCESS SWAY** occurs, take your foot off the gas pedal and hold the steering wheel as steady as possible. **DO NOT** apply your brakes and **DO NOT** speed up.

1. **Limited Lifetime Warranty ("Warranty").** Cequent Performance Products, Inc. ("We", "Us" or "Our") warrants to the original consumer purchaser only ("You" or "Your") that the product will be free from material defects in both material and workmanship, ordinary wear and tear excepted. The Warranty is valid only if (a) the products are returned to Us for inspection and testing; (b) Our inspection discloses to Our satisfaction that any alleged nonconformance are material and have not been caused by misuse, neglect, wear and tear, improper installation, unsuitable storage, improper repair, alteration, or accident; and (c) the products were installed, maintained and used in accordance with Our instructions. **THE WARRANTY IS MADE IN LIEU OF ALL OTHER WARRANTIES, EXPRESS OR IMPLIED (OTHER THAN THE WARRANTY OF TITLE AS PROVIDED BY THE UNIFORM COMMERCIAL CODE IN EFFECT IN MICHIGAN), INCLUDING WITHOUT LIMITATION, ANY WARRANTIES OF MERCHANTABILITY OR FITNESS FOR A PARTICULAR PURPOSE, SAID WARRANTIES BEING EXPRESSLY DISCLAIMED.**
2. **Obligations of Purchaser.** Any returned product that is replaced by Us becomes our property. You may be responsible for return shipping costs. Please retain your purchase receipt to verify date of purchase and that You are the original consumer purchaser. The product and the purchase receipt must be provided to Us in order to process Your Warranty claim.
3. **Exclusive Remedy.** Product replacement is Your sole and exclusive remedy under this Warranty. We shall not be liable for service or labor charges incurred in removing or replacing a product. **IN NO EVENT WILL WE BE RESPONSIBLE FOR ANY INDIRECT, SPECIAL, CONSEQUENTIAL OR PUNITIVE DAMAGES.**
4. **Assumption of Risk.** You acknowledge and agree that any use of the product for any purpose other than the specified use(s) stated in the product instructions is at Your own risk.
5. **Governing Law.** This Warranty gives You specific legal rights, and You also may have other rights which vary from state to state. This Warranty is governed by the laws of the State of Michigan, without regard to rules pertaining to conflicts of law. The state courts located in Oakland County, Michigan shall have exclusive jurisdiction for any disputes relating to this Warranty.



# Installation Instructions

**PART NUMBERS: 76016, 84016, CQT76016**

## Applications:

Years	Make	Models
2014-Current*	GMC	Sierra 1500
2014-Current*	Chevy	Silverado 1500

\*Visit our website for the most up to date information regarding application years and trim levels.

## Installation Time: **25 min.**

The time listed above is the average time for professional installers. If you do not feel comfortable performing this installation on your own or are in need of assistance, please contact a professional installer.



**Representative Vehicle Photo**

## Equipment Required:

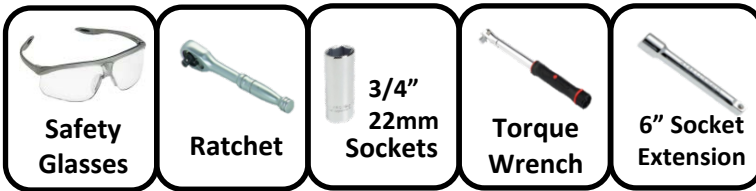

**DO NOT EXCEED LOWER OF TOWING VEHICLE  
MANUFACTURER'S RATING OR:**

Hitch Type	Max Gross Trailer Weight	Max Tongue Weight
Weight Carrying	6000 lb. (2722 kg)	900 lb. (408 kg)
Weight Distributing	10000 lb. (4536 kg)	1000 lb. (454 kg)

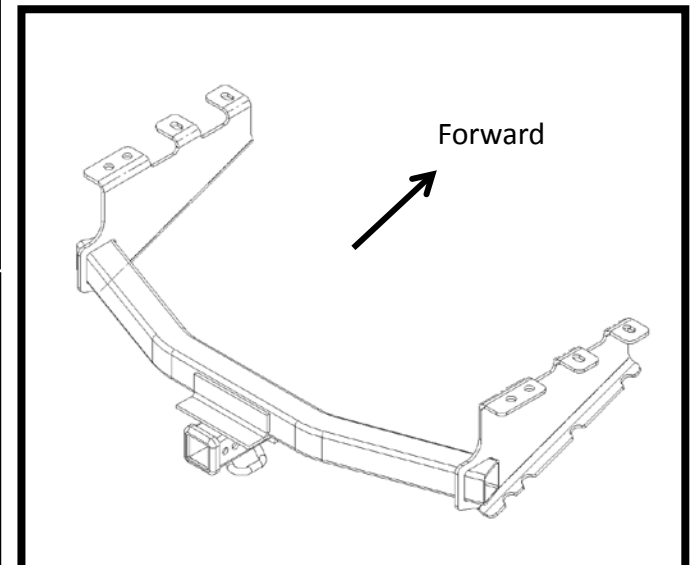

**Hitch Illustration**

**!** Always wear **SAFETY GLASSES** when installing hitch

# Installation Instructions

## PART NUMBERS: 76016, 84016, CQT76016

**FASTENERS TYPICAL**  
**ON BOTH SIDES**

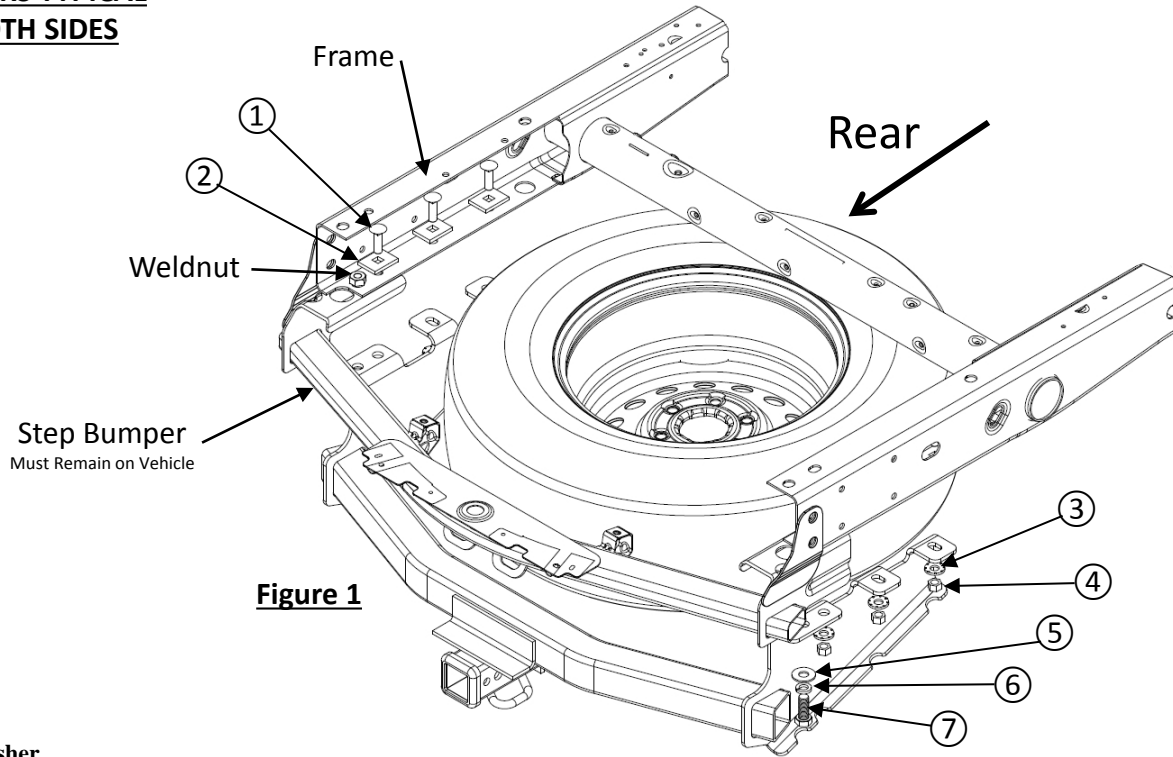

**Figure 1**



**Conical Washer**  
Teeth side  
against hitch

**Figure 2**

### Fastener Kit: 76016F

①	Qty. (6)	Carriage bolt 1/2" - 13 x 1.75 GR5	
②	Qty. (6)	Block 1/4" x 1.5" x 2"	
③	Qty. (6)	Conical washer 1/2"	
④	Qty. (6)	Hex Nut 1/2" - 13 GR5	
⑤	Qty. (2)	Flat Washer 9/16"	
⑥	Qty. (2)	Lock Washer 9/16" Plated	
⑦	Qty. (2)	Hex Bolt CL10.9 M14 x 2.00 x40 mm	

- 1. Lower or Remove the Spare Tire** – Lowering or removing the spare tire will help ease installation.
- 2. Remove the existing M14 bolts** – At the rear of each side of the Frame, remove (1) Factory M14 bolt and return it to the customer.
- 3. Install Hitch** – While lifting the Hitch into position, install (1) supplied M14 bolt with (1) 9/16" Lock Washer and (1) 9/16" Flat Washer into the rear most weldnut on each side of the frame.
- 4. Install Remaining Fasteners** – With the Hitch in position, install the remaining fasteners; (3) 1/2 – 13 Carriage Bolts and (3) 1/4" Blocks inside each side of the Frame and three (3) 1/2" Conical Washers and three (3) 1/2 – 13 Hex Nuts below the Hitch on each side of the Frame.
- 5. Tighten all 1/2 – 13 Grade 5 Fasteners with Torque Wrench to 75 ft-lb (102 N-m) and Tighten all M14 CL 10.9 Fasteners with Torque Wrench to 148 ft-lb (201N-m).**
- ⚠ Proper torque is needed to keep the hitch secure to the vehicle when towing.**
- 6. Re-tighten or re-stow the Spare Tire**

Note: Check hitch frequently, making sure all fasteners and ball are properly tightened. If hitch is removed, plug all holes in trunk pan or other body panels to prevent entry of water and exhaust fumes. A hitch or ball which has been damaged should be removed and replaced. Observe safety precautions when working beneath a vehicle and wear eye protection. Do not cut access or attachment holes with a torch.

This product complies with safety specifications and requirements for connecting devices and towing systems of the state of New York, V.E.S.C. Regulation V-5 and SAE J684.

**1. Lower or Remove the Spare Tire** – Lowering or removing the spare tire will help ease installation.

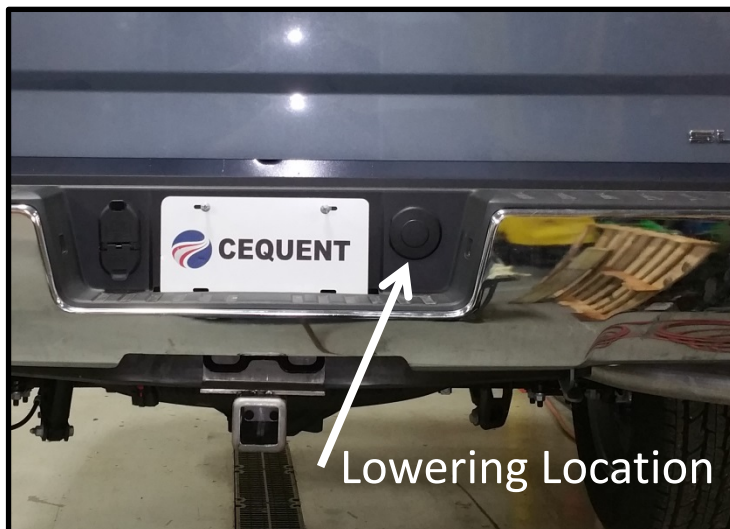

**2. Remove the existing M14 bolts** – At the rear of each side of the Frame, remove (1) Factory M14 bolt and return it to the customer.

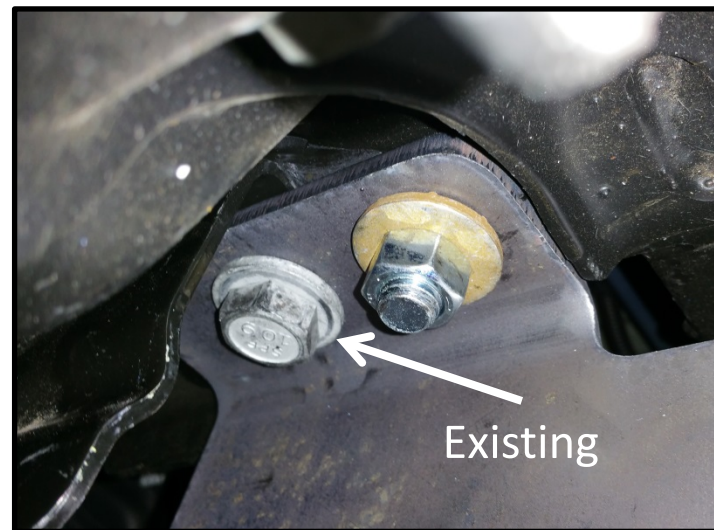

**3. Install Hitch** – While lifting the Hitch into position, install (1) supplied M14 bolt with (1) 9/16" Lock Washer and (1) 9/16" Flat Washer into the rear most weldnut on each side of the frame.

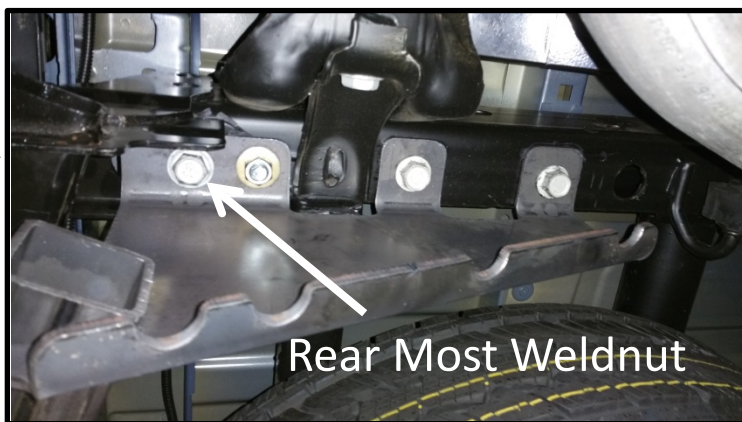

**4. Install Remaining Fasteners** – With the Hitch in position, install the remaining fasteners; (3) 1/2 – 13 Carriage Bolts and (3) 1/4" Blocks inside each side of the Frame and three (3) 1/2" Conical Washers and three (3) 1/2 – 13 Hex Nuts below the Hitch on each side of the Frame.

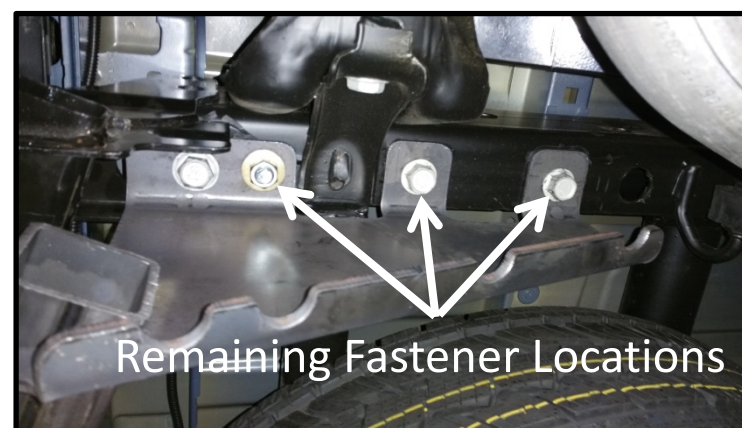

5. Tighten all 1/2 – 13 Grade 5 Fasteners with Torque Wrench to 75 ft-lb (102 N-m) and Tighten all M14 CL 10.9 Fasteners with Torque Wrench to 148 ft-lb (201N-m).

**⚠ Proper torque is needed to keep the hitch secure to the vehicle when towing.**



\*\*Image is of Generic Hitch

6. Re-tighten or re-stow the Spare Tire

