



Installation Instructions

Trailer Tow Harness

READ THIS FIRST:

Read and follow all vehicle warnings and installation instructions before beginning installation. Wear safety glasses and use all safety precautions during installation.

5197410-037

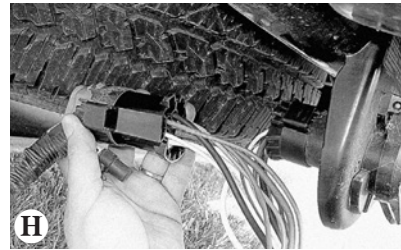
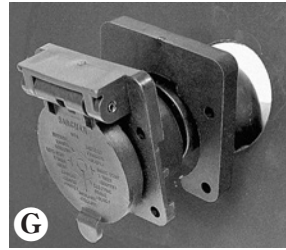
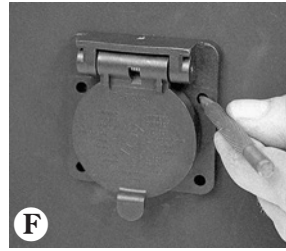
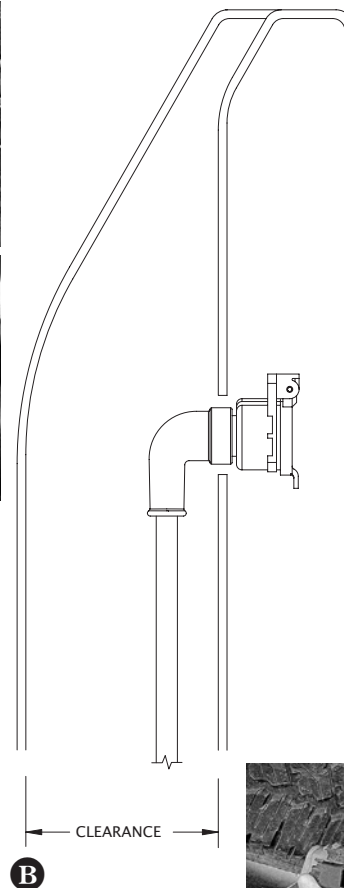
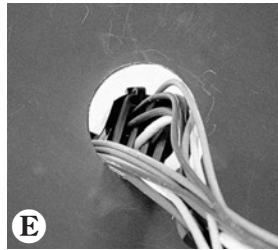
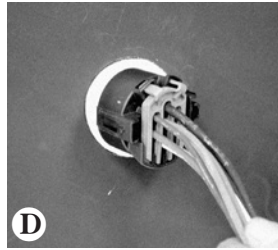
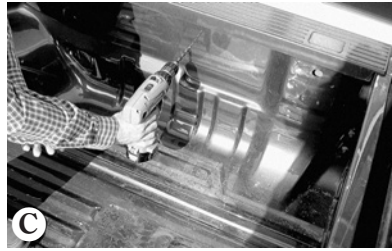
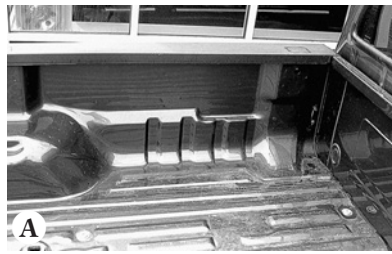

TOOLS REQUIRED:

Drill (3/32" & 1/4" Drill Bits), 2" Hole Saw, 5/16" Socket, Center Punch

1. Determine a suitable mounting point on the tow vehicle for the adapter, usually on the Driver's side between the rear cab post and in front of the wheel well area **A**.

NOTE

Cut away view of truck rail. Make sure there is clearance for mounting **B**.

2. Once a suitable mounting location is found, drill a pilot hole using a drill and 1/4" bit **C**. Re-check your mounting location and wire lengths and then use your 2" hole saw to finish cutting the mounting hole.

CAUTION

Verify what is behind any surface prior to drilling to avoid damage to the vehicle and/or personal injury. Do not drill into any exposed surfaces.

NOTE

If the vehicle has a bedliner it will need to be notched or use a longer set of screws (not provided) and mount directly into the bedliner and body panel.

NOTE

Use rust-proof coating in drilled areas to prevent future rusting (not provided).

3. Route the OE wire connectors through the 2" hole being careful not to scrape or damage the wires against the sharp edges of the sheet metal **D****E**. Using the 7-way end as a guide, mark the mounting hole locations with a center punch **F**. Slide the 7-Way end back and then drill four 3/32" holes as marked.

CAUTION

Verify what is behind any surface prior to drilling to avoid damage to the vehicle and/or personal injury. Do not drill into any exposed surfaces.

NOTE

Use rust-proof coating in drilled areas to prevent future rusting (not provided).

4. Using the 4 self-tapping screws, mount the 7-way harness to the vehicle surface.

NOTE

Use spacer provided in-between the 7-Way plug and the truck bed if the 90 degree bend corner is too close to the outside wall of the truck bed **G**.

WARNING

Route the wire being careful to avoid any hot pipes, heat shields, the fuel tank or any other points that may pinch or break the wire.

5. Locate the vehicle's 7-way factory harness on or near the rear bumper. Separate this connector, being careful not to break the locking tabs. All connector surfaces should be clean and free of dirt. Install the Trailer Tow Harness between the mating plugs **F**.

NOTE

Dodge version is rectangular.

WARNING

All connections must be complete for the Trailer Tow Harness to function properly. Test and verify installation with a test light or trailer once installed.

NOTE

On some vehicles you may need to add a fuse or relay (not provided) to complete all of the functions going to the 7-way. Consult your owner's manual for locations.

6. Secure all loose wiring.