



! WARNING

To prevent SERIOUS INJURY, DEATH or PROPERTY DAMAGE:

- **ALWAYS read, understand and follow warnings and instructions for your hitch BEFORE installation. Keep for future reference.**
- **DO NOT cut, weld or modify this receiver.**
- **CHECK all fasteners are tight and your hitch is securely mounted to your vehicle periodically.**
- **ALWAYS read, understand and follow all warnings and instructions for your vehicle and for other accessories you will use with your hitch BEFORE use.**
- **LOAD the trailer heavier in front.**
- **DO NOT exceed lower of towing vehicle manufacturer's rating or:**

Hitch Type	Max Gross Trailer Weight	Max Tongue Weight
Weight Carrying	2000 lb. (908 kg)	200 lb. (90.8 kg)
Weight Distributing	X	X

- **ALWAYS wear your seatbelt.**
- **SLOW DOWN when towing, NEVER exceed any posted speed limit.**
- **If EXCESS SWAY occurs, take your foot off the gas pedal and hold the steering wheel as steady as possible. DO NOT apply your brakes and DO NOT speed up.**

LIMITED LIFETIME WARRANTY

1. **Limited Lifetime Warranty (“Warranty”).** Cequent Performance Products, Inc. (“We”, “Us” or “Our”) warrants to the original consumer purchaser only (“You” or “Your”) that the product will be free from material defects in both material and workmanship, ordinary wear and tear excepted. The Warranty is valid only if (a) the products are returned to Us for inspection and testing; (b) Our inspection discloses to Our satisfaction that any alleged nonconformance are material and have not been caused by misuse, neglect, wear and tear, improper installation, unsuitable storage, improper repair, alteration, or accident; and (c) the products were installed, maintained and used in accordance with Our instructions. THE WARRANTY IS MADE IN LIEU OF ALL OTHER WARRANTIES, EXPRESS OR IMPLIED (OTHER THAN THE WARRANTY OF TITLE AS PROVIDED BY THE UNIFORM COMMERCIAL CODE IN EFFECT IN MICHIGAN), INCLUDING WITHOUT LIMITATION, ANY WARRANTIES OF MERCHANTABILITY OR FITNESS FOR A PARTICULAR PURPOSE, SAID WARRANTIES BEING EXPRESSLY DISCLAIMED.
2. **Obligations of Purchaser.** Any returned product that is replaced by Us becomes our property. You may be responsible for return shipping costs. Please retain your purchase receipt to verify date of purchase and that You are the original consumer purchaser. The product and the purchase receipt must be provided to Us in order to process Your Warranty claim.
3. **Exclusive Remedy.** Product replacement is Your sole and exclusive remedy under this Warranty. We shall not be liable for service or labor charges incurred in removing or replacing a product. IN NO EVENT WILL WE BE RESPONSIBLE FOR ANY INDIRECT, SPECIAL, CONSEQUENTIAL OR PUNITIVE DAMAGES.
4. **Assumption of Risk.** You acknowledge and agree that any use of the product for any purpose other than the specified use(s) stated in the product instructions is at Your own risk.
5. **Governing Law.** This Warranty gives You specific legal rights, and You also may have other rights which vary from state to state. This Warranty is governed by the laws of the State of Michigan, without regard to rules pertaining to conflicts of law. The state courts located in Oakland County, Michigan shall have exclusive jurisdiction for any disputes relating to this Warranty.

Rev 9/2014

Cequent™ Performance Products, Inc. Installation Instructions



PART NUMBERS: 24950, 77950, CQT24950

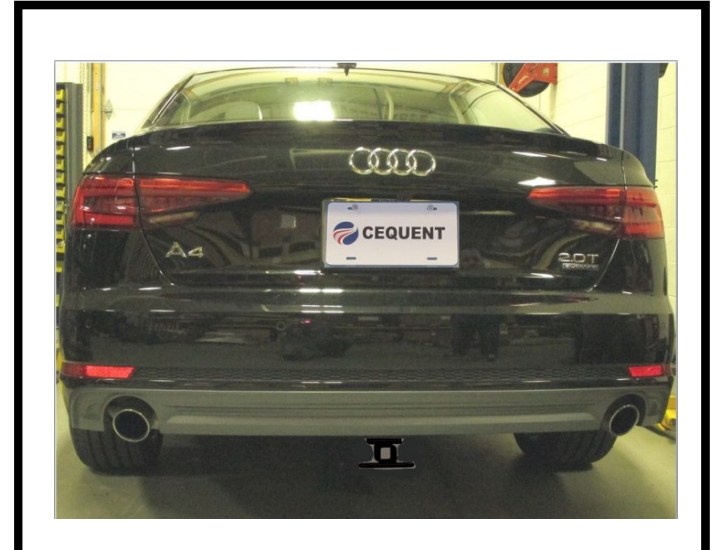
Applications:

Years	Make	Models
2009 -Current*	Audi	A4

*Visit our website for the most up to date information regarding application years and trim levels.

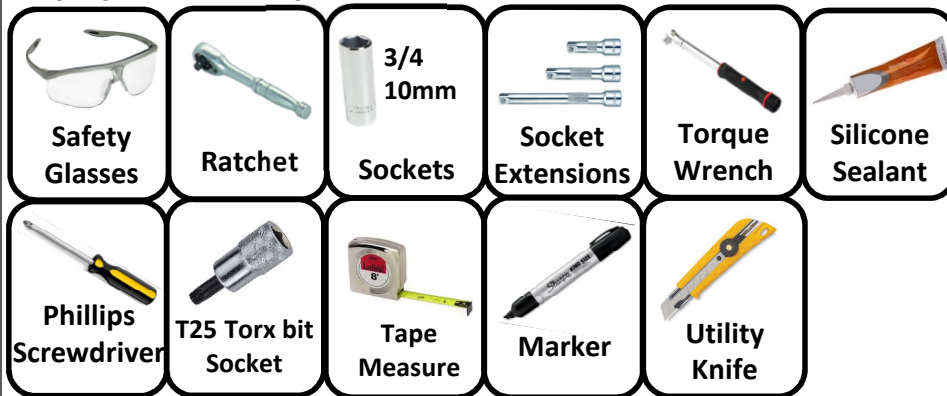
Installation Time: **25 min**

The time listed above is the average time for professional installers. If you do not feel comfortable performing this installation on your own or are in need of assistance, please contact a professional installer.



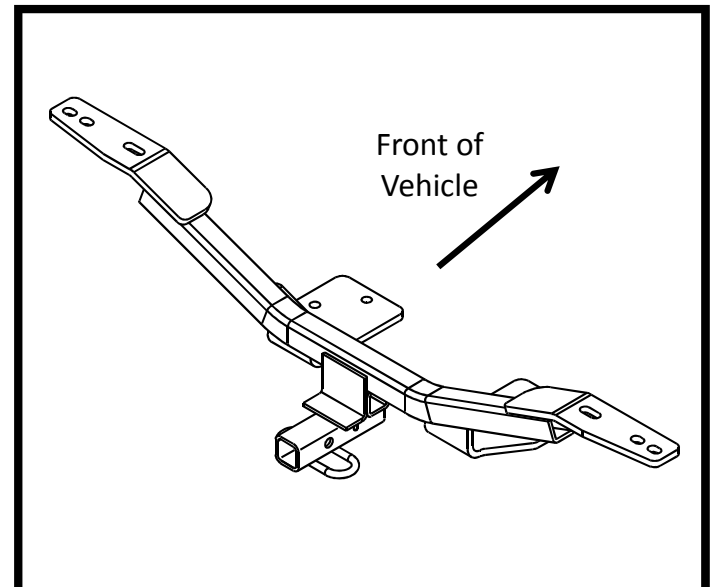
Representative Vehicle Photo

Equipment Required:



DO NOT EXCEED LOWER OF TOWING VEHICLE MANUFACTURER'S RATING OR:

Hitch Type	Max Gross Trailer Weight	Max Tongue Weight
Weight Carrying	2000 lb. (908 kg)	200 lb. (90.8 kg)
Weight Distributing	X	X



Hitch Illustration

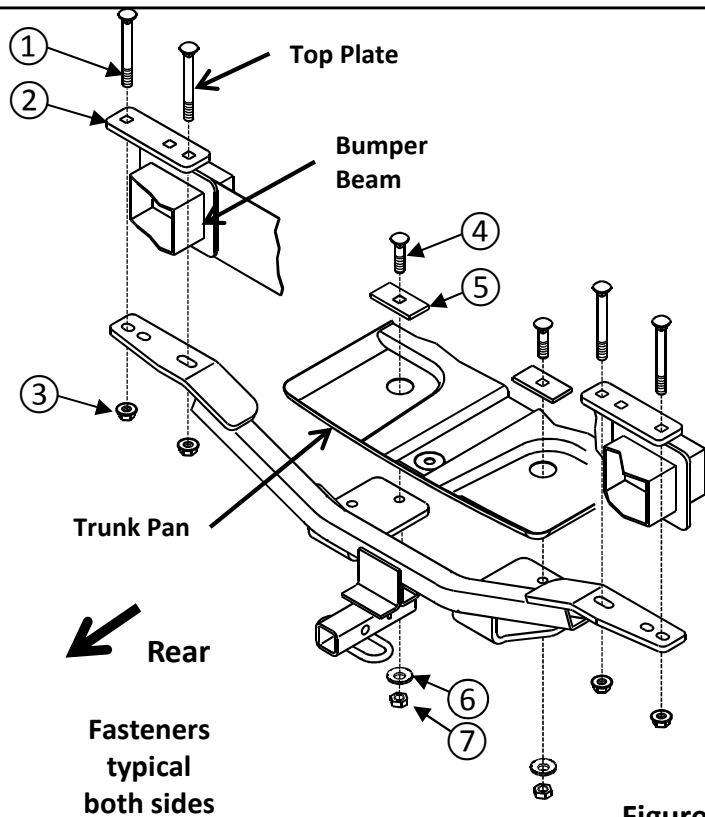


Figure 1

Installation Instructions

PART NUMBERS: 24950, 77950, CQT24950

Authorized Drawbar Kit:
3593 (Sold Separately)
Drawbar must be used in the **RISE** position only.

Always wear SAFETY GLASSES when installing hitch

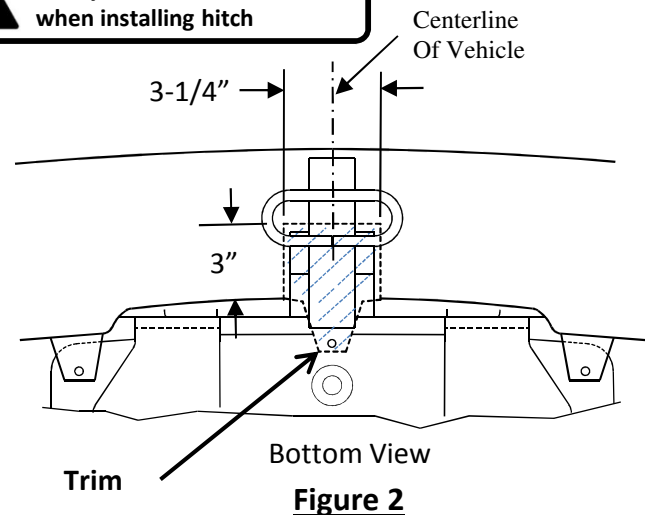
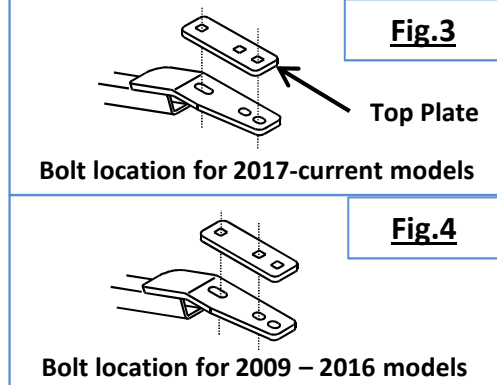


Figure 2

Fastener Kit: 24950F			
①	Qty. (4)	Carriage Bolt 1/2-13 X 4-1/2" GR5	
②	Qty. (2)	Top Plate	
③	Qty. (4)	Hex Flanged Locknut 1/2-13 Grade G	
④	Qty. (2)	Carriage Bolt 1/2-13 X 1-3/4" GR5	
⑤	Qty. (2)	Spacer block 1/2" x 1.50 x 3.00	
⑥	Qty. (2)	Conical toothed washer 1/2"	
⑦	Qty. (2)	Hex Nut 1/2-13 Gr5	



2009 – 2016 models:

1. Using a T25 torx bit, remove (3) screws holding the bumper fascia to the bottom of the trunk pan.

2017 – current models:

- Using a 10mm socket, remove (2) hex nuts holding the bumper fascia to the bottom of the trunk pan.
- Remove underbody panel** – If present (single exhaust models), using a 10mm socket remove (3) hex nuts and (1) push-type rivet and temporarily remove the underbody panel.
- Remove spare tire and jack tool kit** – remove spare tire and using a 10mm socket remove the jack tool kit from trunk.
- Remove drain plugs** – using a utility knife, carefully cut the caulking around the (2) rearmost drain plugs in trunk pan. Remove drain plugs and return to vehicle owner.
- If present, temporarily move hands-free trunk release cable from fascia near area to be trimmed.
- Trim fascia** - using a tape measure, marker, and utility knife, cut a notch in the lower part of fascia, approximately 3-1/4" wide x 3" deep, centered on vehicle as shown in figure 2.
Note: Obtain vehicle owner's permission before trimming fascia.
- Install top plates and fasteners** – gently pull fascia down and install Top Plates with 4-1/2" long carriage bolts on top of bumper beam extensions.
NOTE: The bolt location varies by model year – See figures 3 and 4 for correct top plate bolt location.
- Hitch installation** - raise hitch into position aligning slots in hitch with carriage bolts and loosely install the (4) flanged locknuts onto carriage bolts.
- Seal drain holes** – using silicone caulk, seal around drain holes from inside trunk pan to prevent intrusion of water and exhaust fumes.
- Install fasteners** – install (2) 1-3/4" long carriage bolts and spacer blocks from inside the trunk pan and through holes in hitch. Loosely install the (2) conical toothed washers and hex nuts.
- Tighten all 4-1/2" long Gr5 carriage bolts with torque wrench to 50 Lb.-Ft. (68 N*M)**
- Tighten all 1-3/4" long Gr5 carriage bolts with torque wrench to 75 Lb.-Ft. (102 N*M)** **▲ Proper torque is needed to keep the hitch secure to the vehicle when towing.**
- Reinstall hands-free trunk release cable between hitch bracket and trunk pan.
- Reinstall the underbody panel (if equipped).
- Reinstall (2) screws or (2) hex nuts (depending on model year) to reattach the fascia to the trunk pan.
- Reinstall jack tool kit and spare tire into trunk.

Note: check hitch frequently, making sure all fasteners and ball are properly tightened. If hitch is removed, plug all holes in trunk pan or other body panels to prevent entry of water and exhaust fumes. A hitch or ball which has been damaged should be removed and replaced. Observe safety precautions when working beneath a vehicle and wear eye protection. Do not cut access or attachment holes with a torch. This product complies with safety specifications and requirements for connecting devices and towing systems of the state of New York, V.E.S.C. Regulation V-5 and SAE J684.

2009 – 2016 models:

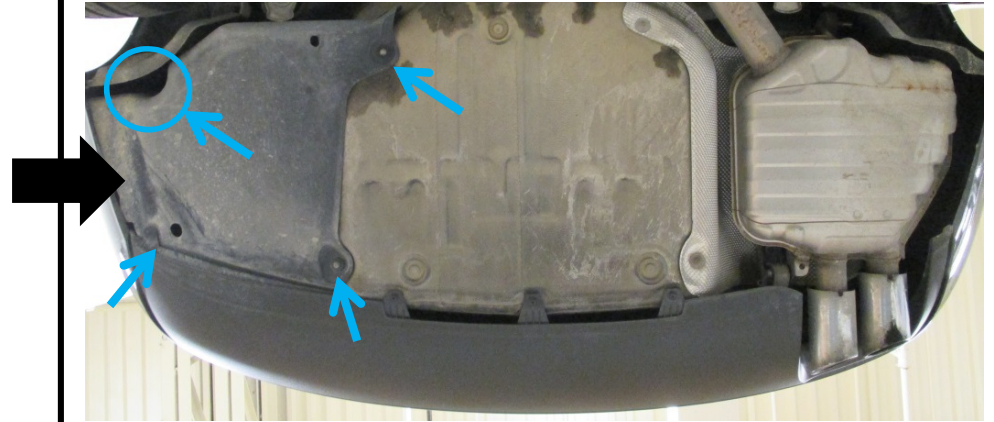
1. Using a T25 torx bit, remove (3) screws holding the bumper fascia to the bottom of the trunk pan.

2017 – current models:

1. Using a 10mm socket, remove (2) hex nuts holding the bumper fascia to the bottom of the trunk pan.



2. **Remove underbody panel** – If present (single exhaust models), using a 10mm socket remove (3) hex nuts and (1) push-type rivet and temporarily remove the underbody panel.



3. **Remove spare tire and jack tool kit** – remove spare tire and using a 10mm socket remove the jack and tool kit from trunk.

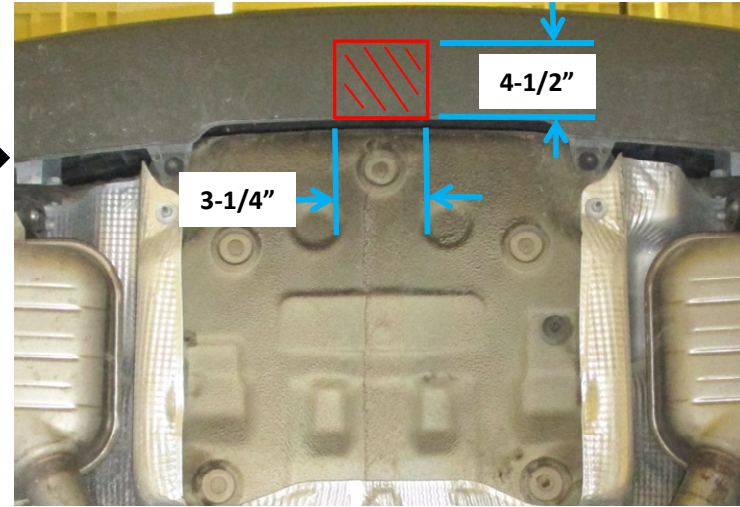


- 4. Remove drain plugs** – using a utility knife, carefully cut the caulking around the (2) rearmost drain plugs in trunk pan. Remove drain plugs and return to vehicle owner.



- 5.** If present, temporarily move hands-free trunk release cable from fascia near area to be trimmed.
- 6. Trim fascia** - using a tape measure, marker, and utility knife, cut a notch in the lower part of fascia, approximately 3-1/4" wide x 3" deep, centered on vehicle as shown in figure 2.

Note: Obtain vehicle owner's permission before trimming fascia.



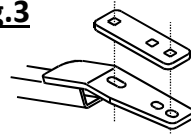
- 7. Install top plates and fasteners** – gently pull fascia down and install Top Plates with 4-1/2" long carriage bolts on top of bumper beam extensions.

NOTE: The bolt location varies by model year .

See figures 3 and 4 for correct top plate bolt location.

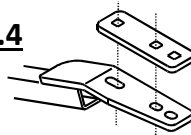


Fig.3



2017-current models

Fig.4

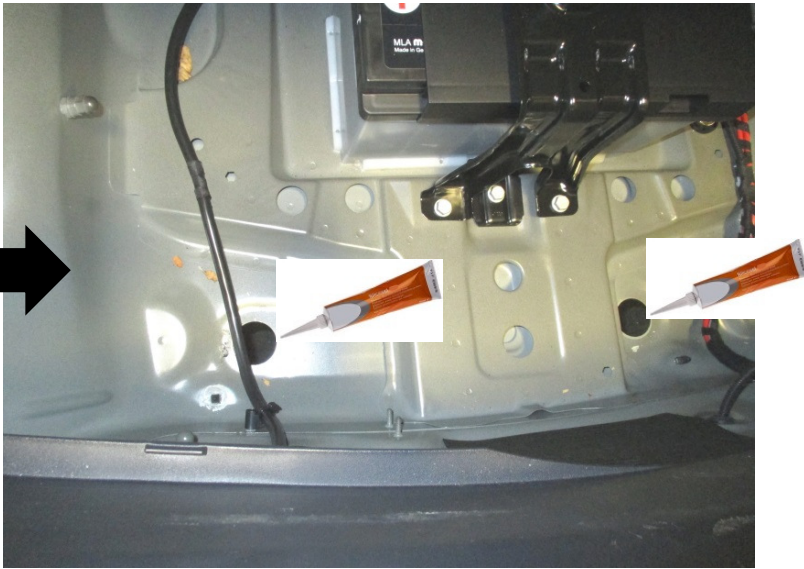


2009 – 2016 models

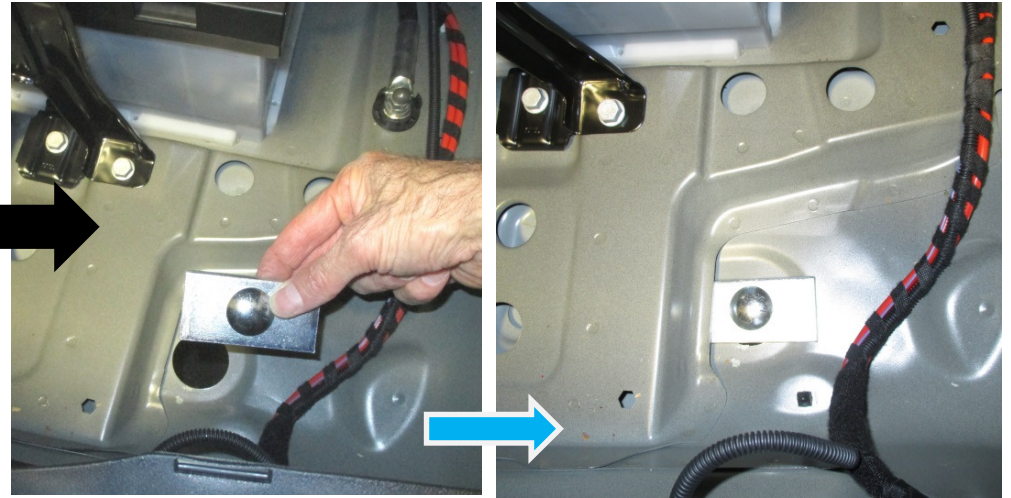
- 8. Hitch installation** - raise hitch into position aligning slots in hitch with carriage bolts and loosely install the (4) flanged locknuts onto carriage bolts, (2) per side.



9. Seal drain holes – using silicone caulk, seal around drain holes from inside trunk pan to prevent intrusion of water and exhaust fumes.



10. Install fasteners – install (2) 1-3/4" long carriage bolts and spacer blocks from inside the trunk pan and through holes in hitch. Loosely install the (2) conical toothed washers and hex nuts.



11. Tighten all 4-1/2" long Gr5 carriage bolts with torque wrench to 50 Lb.-Ft. (68 N*M)

12. Tighten all 1-3/4" long Gr5 carriage bolts with torque wrench to 75 Lb.-Ft. (102 N*M)

⚠ Proper torque is needed to keep the hitch secure to the vehicle when towing.



13. Reinstall hands-free trunk release cable between hitch bracket and trunk pan.
14. Reinstall the underbody panel (if equipped).
15. Reinstall (2) screws or (2) hex nuts (depending on model year) to reattach the fascia to the trunk pan.
16. Reinstall jack, tool kit and spare tire into trunk.

