

Installation Instructions

Chrysler 200

Single exhaust models require underbody shield trimming

Part Numbers:
24919
60352
77306
24481 UH

Drawbar Kit:
 3593
 (Sold separately)

**Do Not Exceed Lower of Towing Vehicle
 Manufacturer's Rating or**

2000 LB (908 Kg) Max Gross Trailer Weight
200 LB (90.8 Kg) Max Tongue Weight

Drawbar must be used in the **RISE** position only.

Wiring Access Location: PC3, 4

Hitch Shown In Proper Position

Equipment Required:

Fastener Kit: 24919F

Wrenches: 11/16, 9/16, 8mm

Drill Bits: N/A

AREA TO BE TRIMMED **Figure 3**

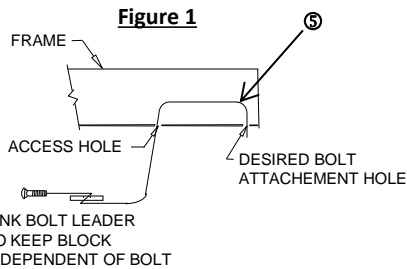
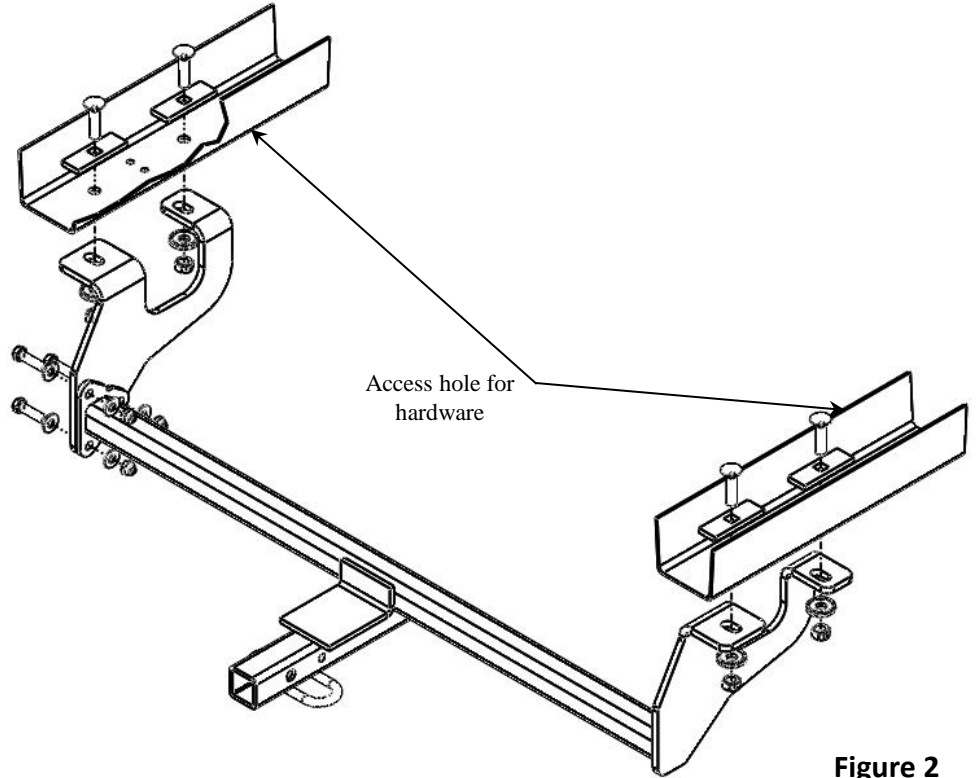
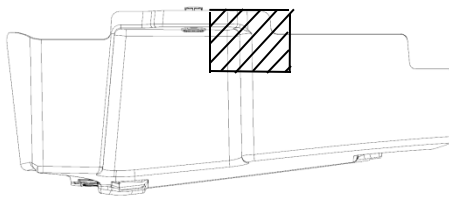

EXAMPLE OF FISHWIRE PROCEDURE

Figure 2

①	Qty. (4)	Carriage bolt 7/16-14 X 1.75 GR5	④	Qty. (4)	NUT 7/16-14
②	Qty. (4)	Spacer 1.00" X 3.00" X .250 Carriage Block	⑤	Qty. (4)	7/16 Bolt Leader (Wireform)
③	Qty. (4)	Conical washer 7/16"	⑥	Qty. (3)	Bolt 3/8-16 X 1.50 GR5
⑦	Qty. (6)	Flat Washer 5/16"	⑧	Qty. (3)	Locknut Hex. 3/8-16

1. Remove bolts and plastic covers from underside of vehicle using and 8mm socket. (Both sides)
2. Remove square rubber plugs from the underside of frame rails. (Both sides)
3. Using square access hole and supplied bolt leader, insert 7/16" bolt and spacer block into frame as show in figure 1.
4. Raise driver side bracket into place, attach conical washers and 7/16" nuts, finger tighten.
5. Raise hitch into position , attach conical washers and 7/16" nuts, finger tighten.
6. Install 3/8" bolts, (with bolt heads facing toward tailpipe) with flatwashers and locknuts through holes in driver side bracket and mating holes in the hitch.
7. Torque all hardware to torque specification below.
8. Reinstall square plug removed from frame rail
9. Reinstall plastic covers. On single exhaust vehicles the plastic cover on the passenger side will need to be trimmed before reinstalling. (Figure 3)

Tighten all fasteners with torque wrench: 7/16-14 GR5 to 50 Lb.-Ft. (68 N*M),
 3/16-16 GR5 to 30 Lb-ft. (41 N*M)

Note: check hitch frequently, making sure all fasteners and ball are properly tightened. If hitch is removed, plug all holes in trunk pan or other body panels to prevent entry of water and exhaust fumes. A hitch or ball which has been damaged should be removed and replaced. Observe safety precautions when working beneath a vehicle and wear eye protection. Do not cut access or attachment holes with a torch.

This product complies with safety specifications and requirements for connecting devices and towing systems of the state of New York, V.E.S.C. Regulation V-5 and SAE J684.