

# Installation Instructions

## Ford Fiesta Sedan

Part Numbers:

**24910**

**60342**

**77297**

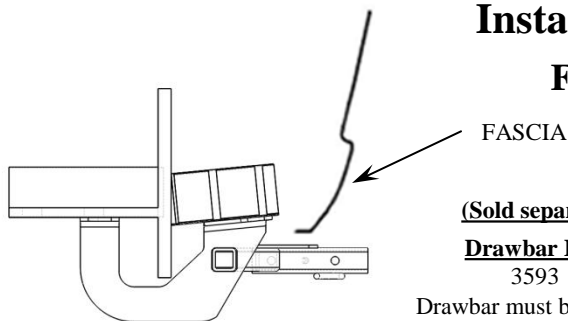

**(Sold separately)**

**Drawbar Kit:**

3593

Drawbar must be used in the **RISE** position only.

**Do Not Exceed Lower of Towing Vehicle Manufacturer's Rating or**

**2000LB (908Kg) Max Gross Trailer Weight**

**200 LB (90.8 Kg) Max Tongue Weight**

**Wiring Access Location: PC 3, 4**

**Hitch Shown In Proper Position**

**Equipment Required: Fishwire (provided)**

**Fastener Kit: 24910F**

**Wrenches: 5/8", 11/16"**

**Drill Bits: none**

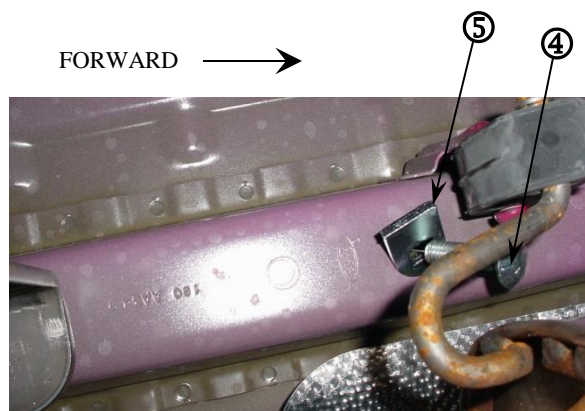
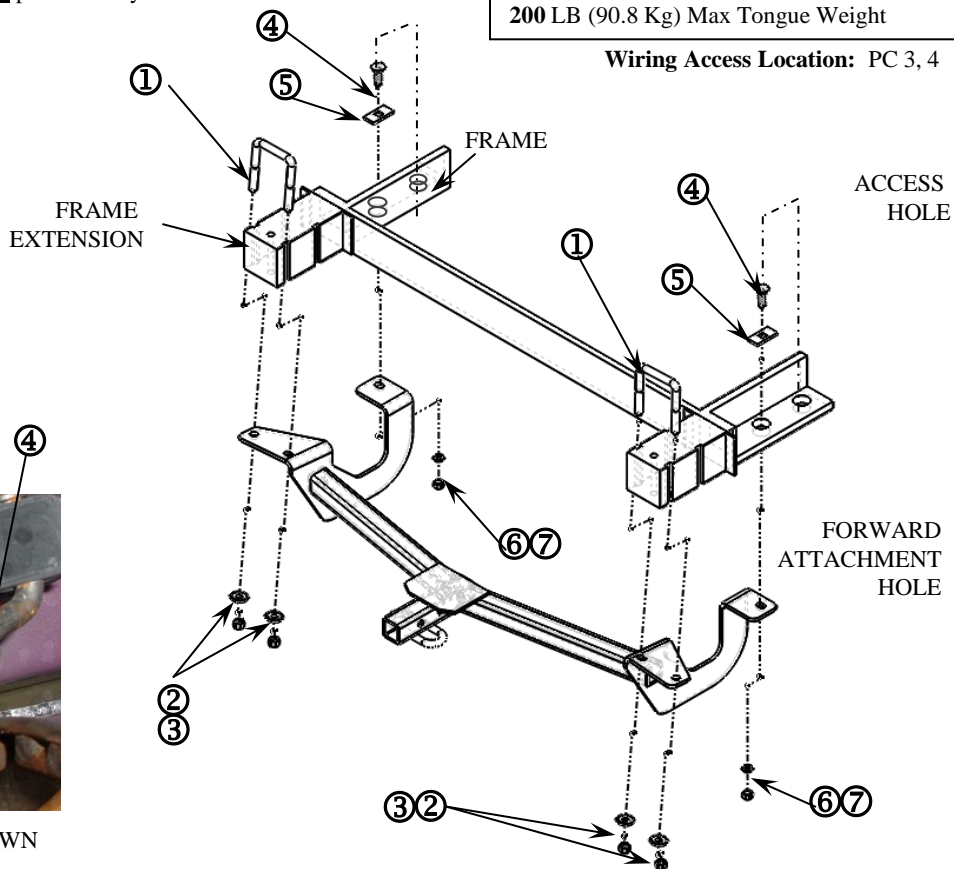

PASSENGER SIDE FRAME RAIL SHOWN

①	Qty. (2)	U-BOLT 7/16-20	⑤	Qty. (2)	BLOCKS – 3/16 X 1 X 2
②	Qty. (4)	CONICAL WASHER – 7/16	⑥	Qty. (2)	LOCK WASHER – 7/16
③	Qty. (4)	NUT – 7/16-20	⑦	Qty. (2)	NUT – 7/16-14
④	Qty. (2)	CARRIAGE BOLT 7/16-14 X 1-1/2	⑧	Qty. (1)	Fishwire

- Place the U-bolts in rear most indentation in frame extension as shown.
- Raise hitch into place and loosely install the conical washers and 7/16-20 (fine thread) nuts.
- Using the fishwire (provided) insert coiled end thru forward attachment hole in hitch, into the frame, and out the access hole. Slide block on and thread carriage bolt into the coil of the fishwire. Keep block and bolt separate until inside frame (see photo above). Pull carriage bolt and block into position with the thread showing below hitch side bracket. Install lock washer and 7/16-14 (course thread) nut.
- Tighten all fasteners to the required torque specifications.

Tighten all 7/16 fasteners with torque wrench to 50 Lb.-Ft. (68 n\*m)

Note: check hitch frequently, making sure all fasteners and ball are properly tightened. If hitch is removed, plug all holes in trunk pan or other body panels to prevent entry of water and exhaust fumes. A hitch or ball which has been damaged should be removed and replaced. Observe safety precautions when working beneath a vehicle and wear eye protection. Do not cut access or attachment holes with a torch.

This product complies with safety specifications and requirements for connecting devices and towing systems of the state of New York, V.E.S.C. Regulation V-5 and SAE J684.