

# Installation Instructions

## Kia Rio 5 Door Hatchback

All models including LX, EX, & SX

Part Numbers:

24883, 60300, 77270

(Sold separately)

**Drawbar Kit:**

3593

**Do Not Exceed Lower of Towing Vehicle  
Manufacturer's Rating or**

**2000 LB (908 Kg) Max Gross Trailer Weight**

**200 LB (90.8 Kg) Max Tongue Weight**

**Wiring Access Location: PC3, PC4**

### Hitch Shown In Proper Position

#### Equipment Required:

**Fastener Kit:** 24883F

**Wrenches/Socket:** 10mm, 11/16, 3/4

**Drill Bits:** None

**Other Tools:** socket extension, small  
Phillips screwdriver

Insert coiled end of Bolt  
Leader through block and  
screw on to bolt. You are  
now ready to push assembly  
up through frame attachment  
hole and back down through.

Large attachment hole in  
bottom of frame for fish-  
wiring bolts with blocks.  
Remove rubber plug and give  
back to vehicle owner.  
Typical both sides of vehicle.

Fasteners typical,  
both sides of vehicle.

9 This is a magnified  
view of a Bolt Leader

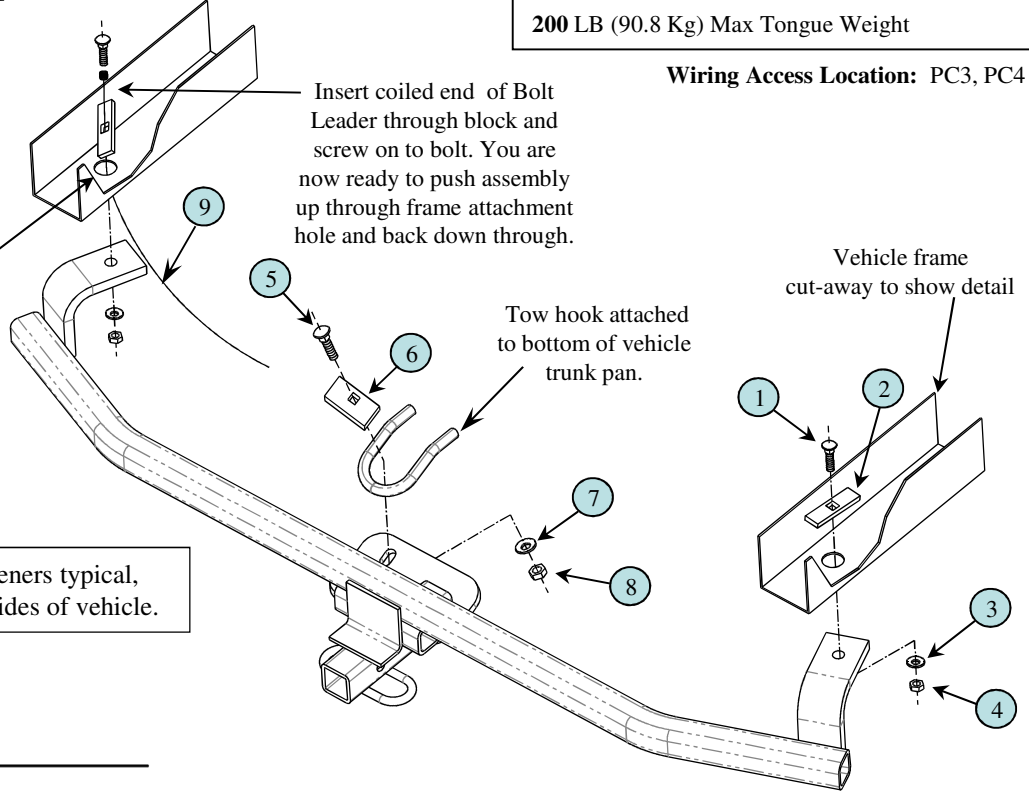
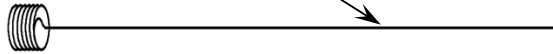

1	Qty. (2)	Carriage Bolt, 7/16"-14 x 1-1/2", Gr. 5	6	Qty. (1)	Block Spacer, 1-1/2" x 3", with square hole
2	Qty. (2)	Block, 7/8" x 3", with square hole	7	Qty. (1)	Conical Toothed Washer, 1/2"
3	Qty. (2)	Conical Toothed Washer, 7/16"	8	Qty. (1)	Hex Nut, 1/2"-13
4	Qty. (2)	Hex Nut, 7/16"-14	9	Qty. (2)	Bolt Leader, 7/16"
5	Qty. (1)	Carriage Bolt, 1/2"-13 X 2", Gr. 5			Another Fine <b>Cequent Performance Products</b> hitch

- Remove plastic trim panel on driver's side of vehicle by removing (3) plastic clips and (3) 10mm nuts. Also remove rubber plugs from attachment holes in frame. See **Picture 1. & 2.** next page. Return panel, fasteners and plugs to vehicle owner.
- Drop vehicle exhaust by removing rubber isolator out of metal peg on muffler on passenger's side vehicle.
- Fish-wire 7/16" carriage bolts and blocks with bolt leaders up through large round attachment holes in bottom of vehicle frame and then back down through same holes; both sides of vehicle. Leave bolt leader wires in place to help guide bolts through hitch in Step 5. below.
- Locate center attachment to vehicle tow hook. Place 1-1/2" wide spacer block with 1/2" carriage bolt in block on top of vehicle tow hook with bolt hanging down.
- Raise hitch into position above tailpipe. Locate hitch sidearm's on bottom of frame, being careful to guide bolt leader wire ends through holes in hitch sidearm's. Pull ends of carriage bolts through hitch sidearm's and remove bolt leaders and loosely install conical toothed washers and hex nuts. Make sure carriage bolts engage with square hole in block as you pull bolts through hitch.
- Install 1/2" conical washer and 1/2" nut on bottom of hitch center attachment and torque to specifications below. Torque 7/16" nuts from Step 5. to specifications below. Reinstall exhaust hanger in place.

Tighten 7/16"-Gr.5 Carriage Bolts with torque wrench to 50 Lb.-Ft. (68 N\*M), Tighten 1/2"-Gr.5 Carriage Bolts with torque wrench to 75 Lb.-Ft. (102 N\*M)

Note: check hitch frequently, making sure all fasteners and ball are properly tightened. If hitch is removed, plug all holes in trunk pan or other body panels to prevent entry of water and exhaust fumes. A hitch or ball which has been damaged should be removed and replaced. Observe safety precautions when working beneath a vehicle and wear eye protection. Do not cut access or attachment holes with a torch.

This product complies with safety specifications and requirements for connecting devices and towing systems of the state of New York, V.E.S.C. Regulation V-5 and SAE J684.

# Installation Instructions

## Kia Rio 5 Door Hatchback

All models including LX, EX, & SX

Part Numbers:  
24883, 60300, 77270

**Picture 1.**

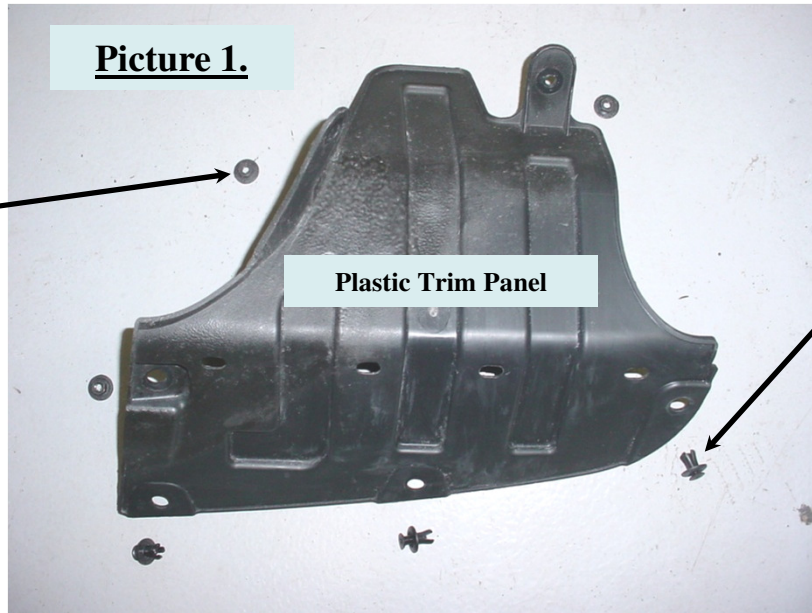

Nuts to be removed from plastic trim panel. (3) total. Use 10mm wrench/socket.

Plastic clips to be removed from trim panel. (3) total. Use a Phillips style screwdriver to loosen and pry out.

**Picture 2.**

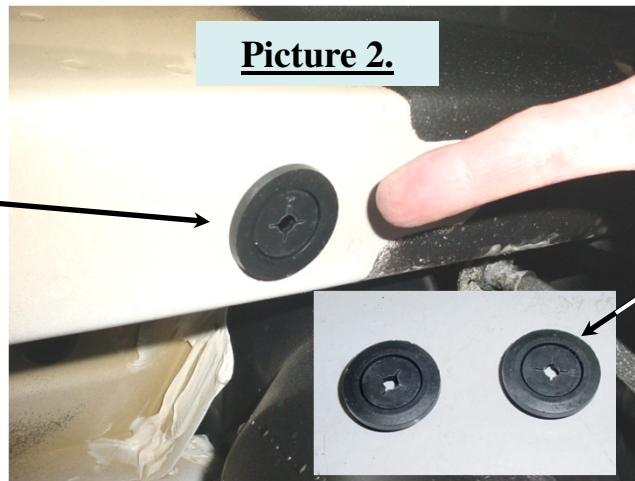

Bottom view of vehicle frame showing rubber plug in attachment hole.

**Return all removed parts to vehicle owner.**

Remove these rubber plugs from attachment holes both sides of vehicle.

**Picture 3.**  
**Installed hitch**

Can you see it?



Tighten 7/16"-Gr.5 Carriage Bolts with torque wrench to 50 Lb.-Ft. (68 N\*M), Tighten 1/2"-Gr.5 Carriage Bolts with torque wrench to 75 Lb.-Ft. (102 N\*M)

Note: check hitch frequently, making sure all fasteners and ball are properly tightened. If hitch is removed, plug all holes in trunk pan or other body panels to prevent entry of water and exhaust fumes. A hitch or ball which has been damaged should be removed and replaced. Observe safety precautions when working beneath a vehicle and wear eye protection. Do not cut access or attachment holes with a torch.

This product complies with safety specifications and requirements for connecting devices and towing systems of the state of New York, V.E.S.C. Regulation V-5 and SAE J684.