

Installation Instructions

Part Numbers:

VOLKSWAGEN PASSAT

Lower fascia panel will need to be trimmed

24880

60297

77267

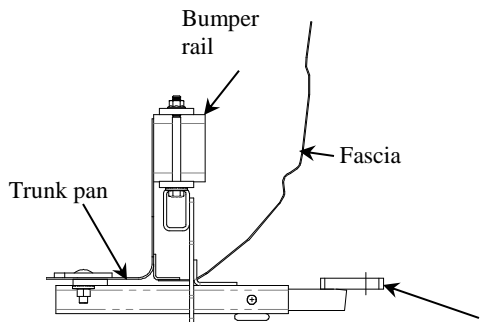

Drawbar Kit: 3590 (Sold separately)

Drawbar must be used in the **RISE** position only.

Do Not Exceed Lower of Towing Vehicle Manufacturer's Rating or

2000 LB (908 Kg) Max Gross Trailer Weight

200 LB (90.8 Kg) Max Tongue Weight

Hitch Shown In Proper Position

Equipment Required: Tape, Utility Knife or cutting wheel, Tape Measure & Marking Pencil, Silicone sealant.

Fastener Kit: 24880F

Wrenches: 15 torxbit, 25 torxbit, 10mm, 13mm, 3/4" socket,

Drill Bits: 1/4" if needed

Recommend 1/4" drill in corners

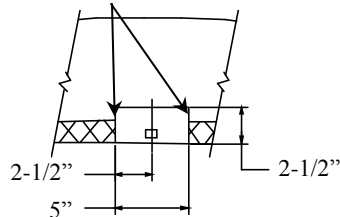

Center fascia tab location.

Figure 1.

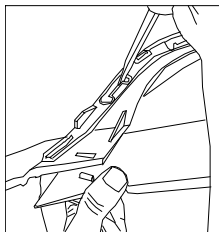

Loosen or remove the lower fascia panel – using a small screwdriver insert in top of slot and gently twist

Figure 2.

Note: Fasteners typical both sides

Wiring Access Location: PC3 & 4

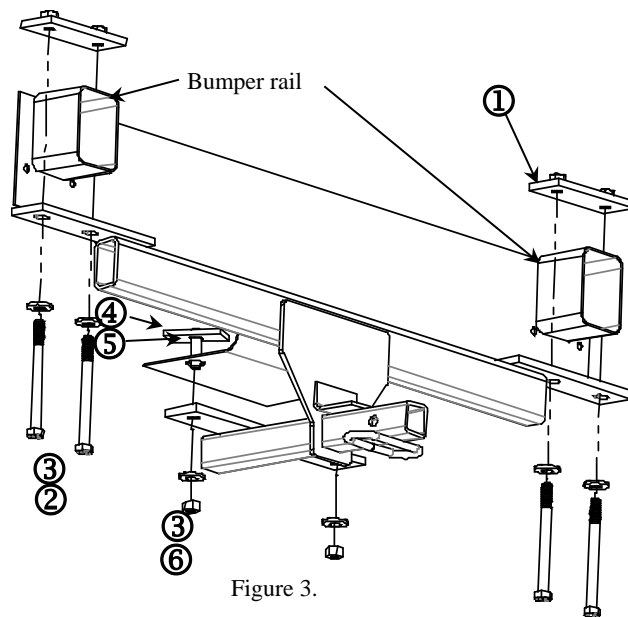

Figure 3.

①	Qty. (2)	Bolt plate	④	Qty. (2)	Carriage bolt 1/2-13 X 1.75 GR5
②	Qty. (4)	Hex bolt 1/2-13 X 5.50 GR5	⑤	Qty. (2)	Spacer
③	Qty. (6)	Conical washer 1/2"	⑥	Qty. (2)	Hex nut 1/2-13

- Remove spare tire from vehicle. Remove the (2) rearward drain plugs and return to owner.
- If present remove the appearance panel on the passenger side. DO NOT REMOVE CANISTER ON DIESEL MODELS.
- Remove the (3) torx screws and clips.
- Lower exhaust by removing the (2) hex bolts at the exhaust hanger.
- Loosen or remove the lower fascia panel – using a small screwdriver insert in top of slot and gently twist as you gently apply pressure. See Figure 2.
- Trim lower fascia panel as shown in Figure 1. Lay out the area to be trimmed by marking with tape or marking pencil (recommend drilling 1/4" minimal holes in corners).
- Place the bolt plates on top of the bumper rails (as shown).
- Raise hitch into position. If, lower appearance panel not completely removed slide under the passenger side all the way over until you have the clearance to raise the drivers side into position (hitch must be raise over existing facial tabs.
- Install the hex bolts and conical washers into the bolt plate. Do not completely tighten.
- Install the carriage bolts and spacer into the trunk drain holes. Use silicone sealant on the bolt plate to assure a seal.
- Seal around the bar at the trunk pan connection and install the conical washer and hex nut.
- Tighten all fasteners to the required torque specification.
- Reinstall the lower fascia panel (line up slot and gently push back into position). Reinstall (2) torx screws and clips. Reinstall the appearance panel if removed.
- Reinstall exhaust.
- Place spare tire back into trunk.

Tighten all 1/2" fasteners with torque wrench to 75 Lb.-Ft. (102 N*M)

Note: check hitch frequently, making sure all fasteners and ball are properly tightened. If hitch is removed, plug all holes in trunk pan or other body panels to prevent entry of water and exhaust fumes. A hitch or ball which has been damaged should be removed and replaced. Observe safety precautions when working beneath a vehicle and wear eye protection. Do not cut access or attachment holes with a torch.

This product complies with safety specifications and requirements for connecting devices and towing systems of the state of New York, V.E.S.C. Regulation V-5 and SAE J684.