

# Installation Instructions

## Fiat 500, 500c (convertible), 500 Turbo

(Turbo model requires fascia trimming)

Part Numbers:

**24873, 60289**

**77255, 24761** U-Haul

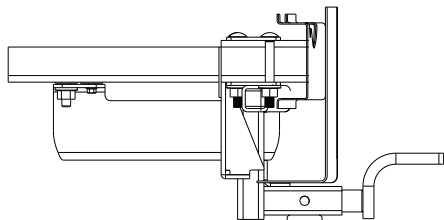

### Hitch Shown In Proper Position

Drawbar must be used in the **Rise** position only.

**Do Not Exceed Lower of Towing Vehicle  
Manufacturer's Rating or**

**2000 LB (908 Kg) Max Gross Trailer Weight**

**200 LB (91 Kg) Max Tongue Weight**

**Wiring Access Location: PC1, PC2**

**Equipment Required: Fish wire (included)  
Spray lube**

**Fastener Kit: 24873F**

**Wrenches: 7/8, M8, M13**

**Drill Bits: None**



SPARE TIRE LIFT

FORWARD

FORWARD  
ATTACHMENT  
HOLE

RUBBER PLUG

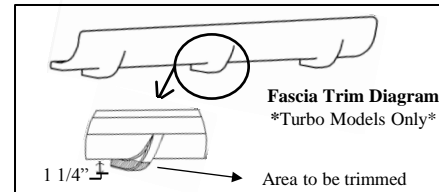
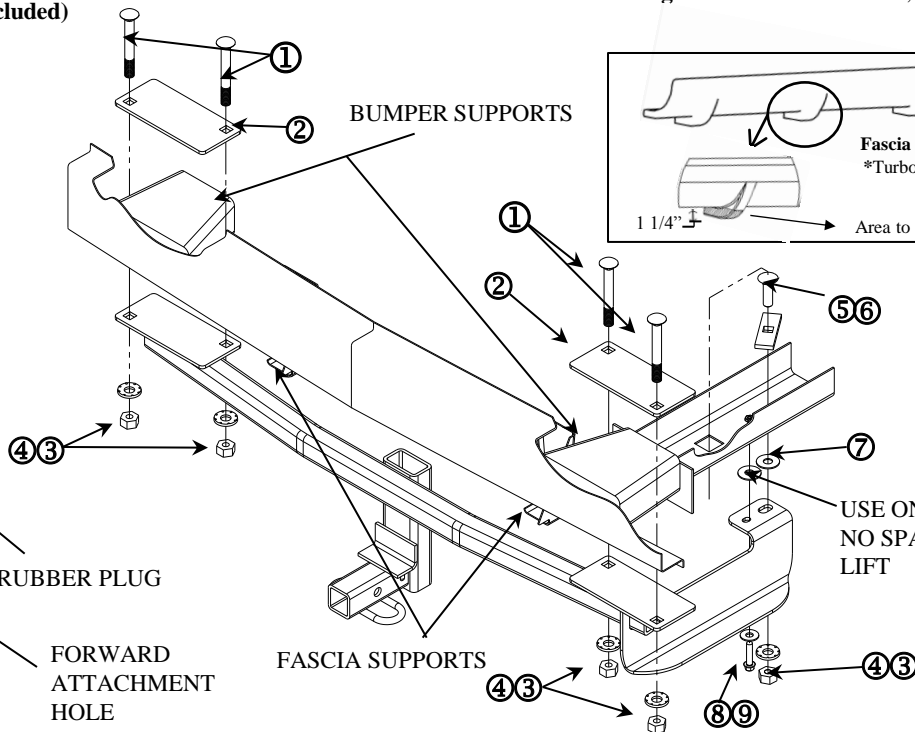

**Fascia Trim Diagram**  
\*Turbo Models Only\*

1 1/4"

Area to be trimmed

USE ONLY IF  
NO SPARE TIRE  
LIFT

①	Qty. (4)	Carriage Bolt – 1/2 – 13 x 4.00 gr5	⑥	Qty. (1)	Block – 1 x 3 x 1/4
②	Qty. (2)	Plates – 3-1/16 x 6-3/4 x 3/16	⑦	Qty. (2)	Flat Washer – 1/2
③	Qty. (5)	Washer – Conical toothed 1/2"	⑧	Qty. (1)	Bolt – M8x1.25 x 30mm
④	Qty. (5)	Nut – 1/2 -13	⑨	Qty. (1)	Washer conical toothed – 3/8"
⑤	Qty. (1)	Carriage Bolt – 1/2 – 13 x 1-3/4 gr5			

- Lower spare tire if it has one. Raise vehicle.
- If spare tire is present, lower spare tire lift by removing (2) M8 screws and (1) M8 nut with m13 socket. Remove rubber plug in frame and fish wire item 5 and 6 into existing hole. Replace rubber plug and spare tire lift. Leave fish wire on bolt.
- Remove two fascia mounting screws from fascia supports with m8 wrench.
- Lower muffler by removing the two pins from the two rubber mounts at the rear of the muffler. It helps if the pins are lubed and the exhaust is gently pulled rearward.
- Place plates (item 2) on top of bumper support as shown and install carriage bolts (item 1) Hint: It is easier if the plate is fed in from the center with the outer bolt already in the plate.
- Gently pull the fascia down and slide the hitch between the fascia and its support. On turbo models, trim center fin flush and horizontal to the lower edge of the bumper (see fascia trim diagram above). Put washer (item 7) in place and thread the fish wire through proper hole in bracket.
- Raise hitch into place as shown and loosely install washers and nuts to bolts (item 1). Pull fish wire with bolt into position, remove the fish wire and install washer and nut. Install M8 bolt and washer (item 8 and 9) thru bracket and into weld nut in frame.
- Push hitch forward and tighten all fasteners

**Tighten all M8 fasteners with torque wrench to 20 Lb.-ft. (27 N\*m)**

**Tighten all 1/2" fasteners with torque wrench to 50 Lb.-ft. (68 N\*m)**

**Note:** check hitch frequently, making sure all fasteners and ball are properly tightened. If hitch is removed, plug all holes in trunk pan or other body panels to prevent entry of water and exhaust fumes. A hitch or ball which has been damaged should be removed and replaced. Observe safety precautions when working beneath a vehicle and wear eye protection. Do not cut access or attachment holes with a torch.

This product complies with safety specifications and requirements for connecting devices and towing systems of the state of New York, V.E.S.C. Regulation V-5 and SAE J684.