

Installation Instructions

Ford Mustang

Part Numbers:

24747

60809

77124

24777 (U-Haul)

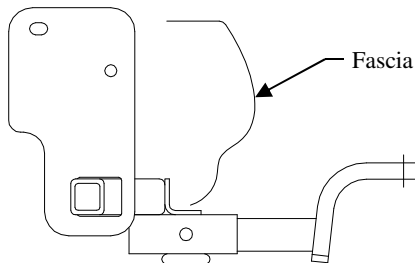

(Sold separately)

Drawbar Kit:

3592

Drawbar must be used in the Rise position only.

**Do Not Exceed Lower of Towing Vehicle
Manufacturer's Rating or**

2000 LB (908 Kg) Max Gross Trailer Weight

200 LB (90.8 Kg) Max Tongue Weight

Hitch Shown In Proper Position

Equipment Required: Drill

Fastener Kit: 60809F

Wrenches: Ratchet, Extension, 13mm, 11/16

Drill Bits: 3/8"

Wiring Access Location: PC3, PC4

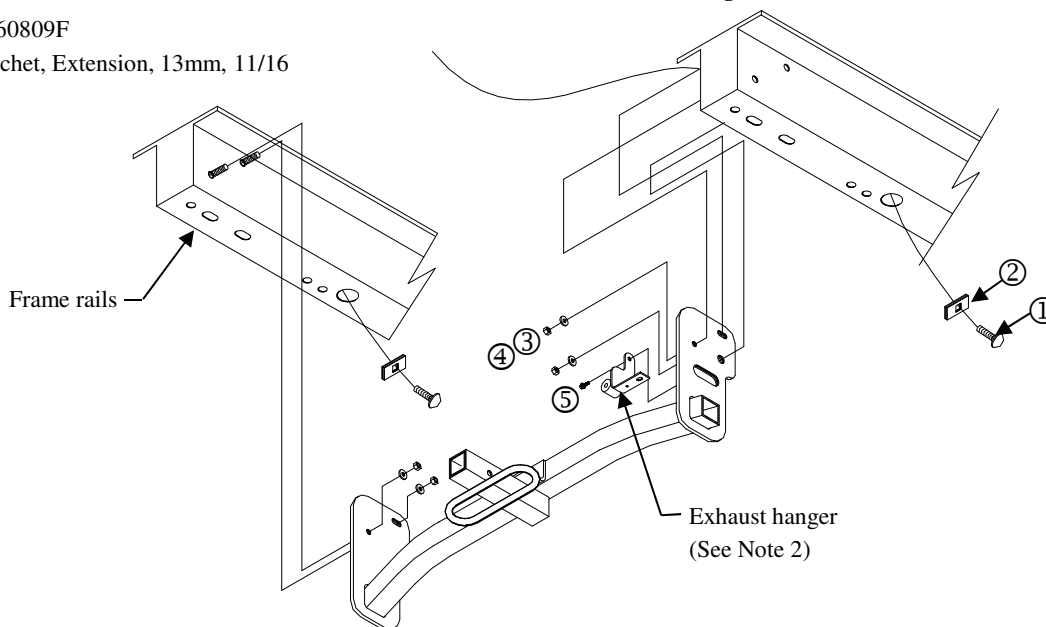

①	Qty. (4)	Carriage Bolt 7/16-14 X 1.50	④	Qty. (4)	Hex Nut 7/16-14
②	Qty. (4)	Spacer	⑤	Qty. (1)	Flange Bolt M8 X 1.25 X 35
③	Qty. (4)	Conical Washer 7/16			

1. Remove rear exhaust hanger and the hanger above the muffler, this will need to be done on both sides on models with dual exhaust.
 2. You will need to open up the hole in the horizontal arm of the exhaust hanger at the rear of the vehicle on the passenger side or bend exhaust hanger to allow installation after hitch is installed.
 3. Using the bolt leaders, fish the hardware into the frame and let it sit inside the frame with the bolt leader tails hanging out through the appropriate holes.
 4. Raise hitch up into place making sure to align horizontal arm on the rear exhaust hanger on the passenger side with the large oblong hole in the frame bracket as you are raising the hitch up into position between the two frame rails, also you will need to insert the ends of the bolt leaders through the holes frame brackets.
- Note: you may need the assistance of another person to help hold the hitch in place until you get the hardware pulled into through the frame brackets, see illustration for clarification.
5. Remove bolt leaders and install nuts on the bolts and install the m8 bolt through the vertical arm of the rear exhaust hanger on the passenger side and the frame bracket into the frame.
 6. Tighten all fasteners as required.
 7. Reinstall the remaining exhaust hangers and make sure all the necessary hardware is back in place.

Tighten all M8 CL8.8 fasteners with torque wrench to 20 Lb.-Ft.(27 N*M)

Tighten all 7/16 GR5 fasteners with torque wrench to 50 Lb.-Ft. (68 N*M)

Note: check hitch frequently, making sure all fasteners and ball are properly tightened. If hitch is removed, plug all holes in trunk pan or other body panels to prevent entry of water and exhaust fumes. A hitch or ball which has been damaged should be removed and replaced. Observe safety precautions when working beneath a vehicle and wear eye protection. Do not cut access or attachment holes with a torch.

This product complies with safety specifications and requirements for connecting devices and towing systems of the state of New York, V.E.S.C. Regulation V-5 and SAE J684.