

Installation Instructions

Part Numbers:

**24850, 60266,
77223, 24893** U-Haul

Chevrolet Camaro

All Models, Excluding convertible
(will not fit vehicles with optional dealer
installed ground effects package)

Do Not Exceed Lower of Towing Vehicle Manufacturer's Rating or

Hitch type	Max Gross Trailer WT (LB)	Max Tongue WT (LB)
Weight Carrying Ball Mount	2000 (908 Kg)	200 (91 Kg)

Wiring Access Location: PC1, PC2

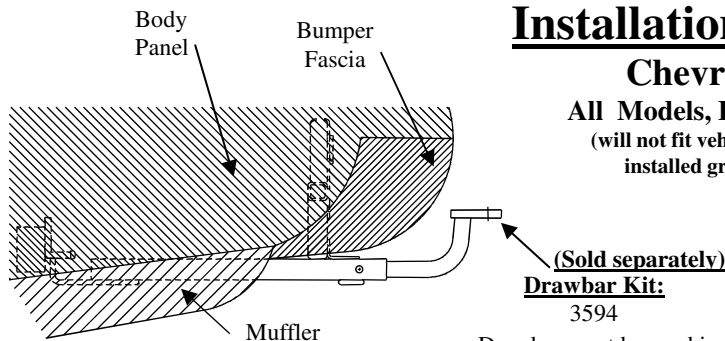

(Sold separately)
Drawbar Kit:
3594

Drawbar must be used in the **RISE** position only.

Hitch Shown In Proper Position

Equipment Required:

Fastener Kit: 24850F

Wrenches: 13mm, 9/16"

Drill Bits: None

Other items: Round file as needed.

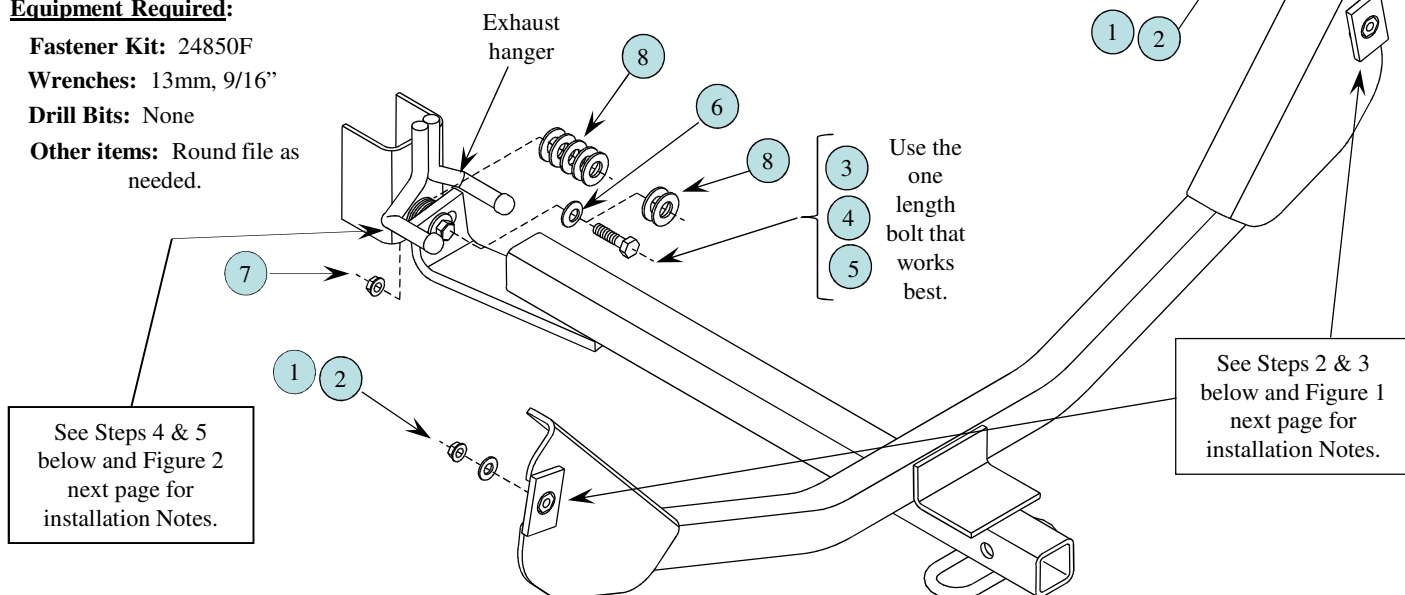

See Steps 4 & 5 below and Figure 2 next page for installation Notes.

Use the one length bolt that works best.

See Steps 2 & 3 below and Figure 1 next page for installation Notes.

1	Qty. (3)	8mm -1.25 CL10 Flanged Locknut, (1 extra)	5	Qty. (1)	3/8"-16 x 2" Gr.5 Hex head Bolt (as needed)
2	Qty. (3)	7/16" Flat Washer (15/16" outside diameter ,1 extra)	6	Qty. (1)	3/8" Conical Toothed Washer
3	Qty. (1)	3/8"-16 x 1-1/2" Gr.5 Hex head Bolt (as needed)	7	Qty. (1)	3/8" -16 Flanged Locknut
4	Qty. (1)	3/8"-16 x 1-3/4" Gr.5 Hex head Bolt (as needed)	8	Qty. (10)	7/16" Heavy Flat Washer (1-1/4" outside diameter). Use as needed, you may not need all of them.

1. Raise hitch into place by turning hitch sideways under vehicle, then carefully raising one end between back of muffler and plastic bumper fascia. Then raise other end into place. If vehicle is not raised on hoist or ramps be careful not to scratch plastic bumper fascia.
2. Hang hitch bracket clearance holes over existing 8mm stud/weldnuts located just rear of mufflers on both sides of vehicle. **See Figure 1 next page.** Make sure that 3/4" diameter clearance holes in hitch brackets sit flat against vehicle sheet metal and do not rest against vehicle weldnuts.
3. Install one 7/16" flat washer, (smaller diameter washer), over one of the existing 8mm studs in vehicle and against hitch bracket just hung in Step 2 above. Then start 8mm flanged locknut on stud and tighten with wrench just enough to keep hitch bracket against vehicle sheet metal. **Note! hitch brackets cannot rest on top of weldnuts on vehicle.** Existing weldnuts must show through hitch bracket clearance holes. Install flat washer and locknut on other side of vehicle the same way making sure that hitch brackets are against vehicle sheet metal and not against weldnuts. As previous tighten locknut just enough to keep hitch in place so that it doesn't fall against weldnuts.
4. Raise forward hitch attachment aligning with existing slot in bracket hanging down off bottom of independent suspension crossbeam. It may be necessary to remove (2) exhaust rubber isolators from hangers to access attachment.
5. Using heavy flat washers, (larger diameter washers), stack together to make up gap between hitch bracket and vehicle bracket. **Caution! make sure that 3/8" bolt is just long enough to go through flanged locknut and doesn't bottom out against aluminum transaxle.** See Figure 2 next page. You may have to put flat washers under head of bolt to keep bolt from bottoming out. Supplied are (3) different length 3/8" bolts. Use the one that works best for your particular vehicle so that bolt does not bottom out against aluminum transaxle but still extends through locknut.
6. Torque 8mm nuts installed in Step 3 to torque shown below for 8mm locknuts. Torque 3/8" bolt installed in Step 5 to torque shown below for 3/8" bolt. Reinstall rubber isolators on exhaust if removed.

Tighten 3/8"-16 Gr.5 bolt with torque wrench to 30 Lb.-Ft. (41 N*M) Tighten 8mm locknuts with torque wrench to 27Lb.-Ft. (37 N*M).

Note: check hitch frequently, making sure all fasteners and ball are properly tightened. If hitch is removed, plug all holes in trunk pan or other body panels to prevent entry of water and exhaust fumes. A hitch or ball which has been damaged should be removed and replaced. Observe safety precautions when working beneath a vehicle and wear eye protection. Do not cut access or attachment holes with a torch.

This product complies with safety specifications and requirements for connecting devices and towing systems of the state of New York, V.E.S.C. Regulation V-5 and SAE J684.

Installation Instructions

Chevrolet Camaro

All Models, Excluding convertible

(will not fit vehicles with optional dealer installed ground effects package)

Part Numbers:

24850, 60266,

77223, 24893 U-Haul

Hitch clearance hole must go over & around existing vehicle stud/weldnut, typical both sides of vehicle.

Figure 1.
View looking rearward on rear attachment

NOTE! This is important to assure that there is enough stud length for washer & locknut.
(It may be necessary in some cases to enlarge hitch hole diameter with a round file to fit over vehicle weldnuts.)

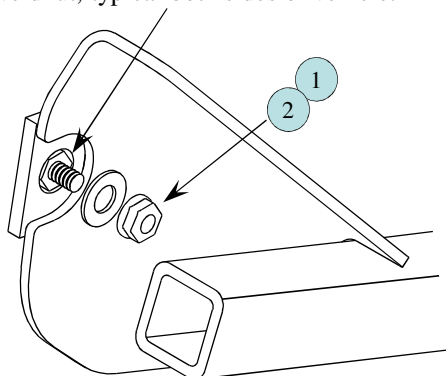

NOTE

*Use flat washers as needed, you may not need to use all off them.

8 *It may be necessary to insert flat washers under head of bolt also to assure that bolt does not bottom out.

3 Use one of the (3) different length 3/8" bolts supplied to make attachment. Mix & match bolt length and flat washers so that joint can be tightened without bottoming out on transaxle mount.

8 *Insert flat washers as needed to fill gap between hitch & vehicle.

6 Conical washer

7 3/8" Locknut

Vehicle transaxle bracket (cut-away to show detail)

Vehicle aluminum transaxle mount

Do not let bolt bottom out on vehicle aluminum transaxle mount.

Hitch bracket

Figure 2.
Side view of forward attachment

Tighten 3/8"-16 Gr.5 bolt with torque wrench to 30 Lb.-Ft. (41 N*M) Tighten 8mm locknuts with torque wrench to 27Lb.-Ft. (37 N*M).

Note: check hitch frequently, making sure all fasteners and ball are properly tightened. If hitch is removed, plug all holes in trunk pan or other body panels to prevent entry of water and exhaust fumes. A hitch or ball which has been damaged should be removed and replaced. Observe safety precautions when working beneath a vehicle and wear eye protection. Do not cut access or attachment holes with a torch.

This product complies with safety specifications and requirements for connecting devices and towing systems of the state of New York, V.E.S.C. Regulation V-5 and SAE J684.