

Installation Instructions

Nissan Sentra

Part Numbers:

24794

60871

77166

(Sold separately)

Drawbar Kit:

3594

**Do Not Exceed Lower of Towing Vehicle
Manufacturer's Rating or**

2000 LB (908 Kg) Max Gross Trailer Weight

200 LB (90.8 Kg) Max Tongue Weight

Drawbar must be used in the
RISE position only.

Wiring Access Location: PC3, PC4

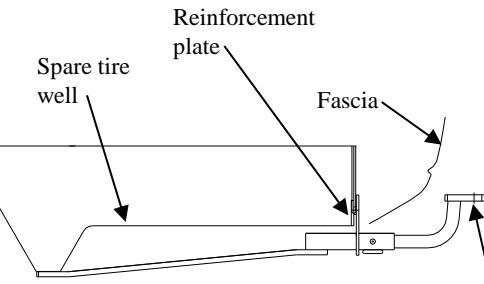

Hitch Shown In Proper Position

Equipment Required: Pull wire (Provided), Sealant

Fastener Kit: 24794F

Wrenches: 3/4"

Drill Bits: 1/2"

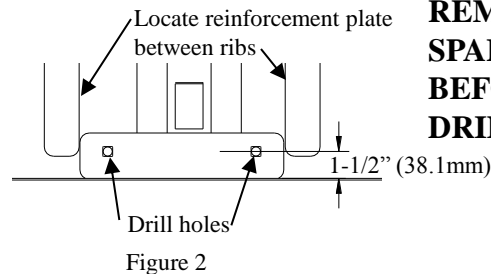
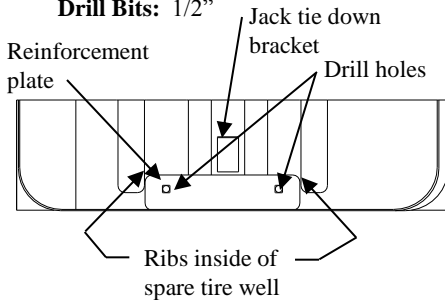

REMOVE SPARE TIRE BEFORE DRILLING

Figure 1

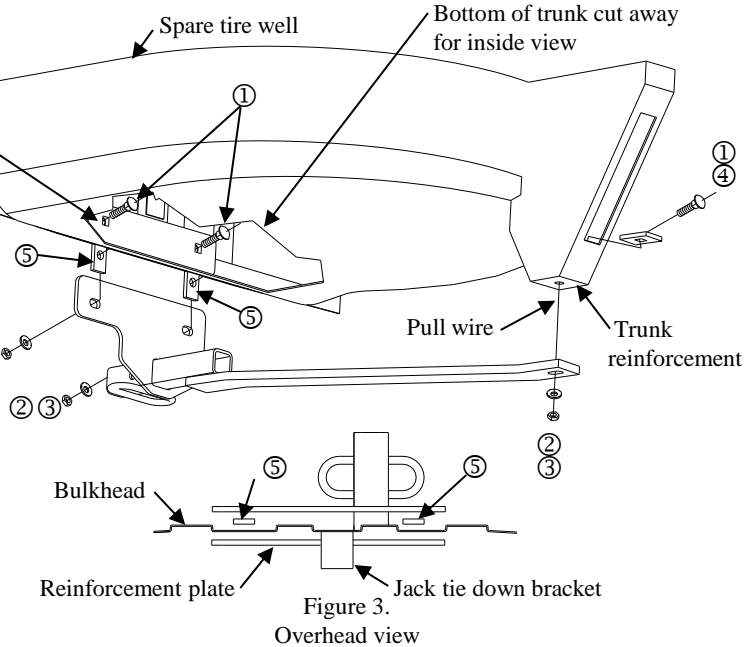

Figure 3.
Overhead view

①	Qty. (3)	Carriage Bolts 1/2-13 X 2.00 GR5	④	Qty. (1)	Spacer .250 X 1.50 X 2.00 (Sq. Hole)
②	Qty. (3)	Conical Washer	⑤	Qty. (2)	Spacer .250 X 1.00 X 2.00 (Rd. Hole)
③	Qty. (3)	Hex Nut 1/2-13			

- 1 REMOVE SPARE TIRE FROM TRUNK. Remove jack from tie down bracket.
- 2 Remove the (2) plastic rivets that fasten the fascia tabs to the vehicle. Note: Remove the center of the rivet with a screwdriver. Rivets to be reinstalled.
- 3 Scrape undercoating off bottom of the surface of the trunk reinforcement.
- 4 Attach pull wire to carriage bolt and through spacer (Item 4) insert using slot located behind the trunk reinforcement making sure the spacer and carriage bolt sit flat at the bottom.
- 5 Place reinforcement plate inside spare tire well, at the bottom of trunk. Locate the 1-1/2" length against the bottom of the trunk. Place between the ribs as shown in Figure 2. Drill two holes.
- 6 Insert the carriage bolts through the reinforcement bracket and place (2) spacer (Item 5) on the carriage bolts from opposite side of bulkhead.
- 7 Lift hitch into position onto the two carriage bolts, sandwiching the spacer between the bulkhead and hitch. See Figure 3. Loosely attach conical washer and hex nuts.
- 8 Attach bar to trunk reinforcement using conical washer and hex nut (Item 2 & 3).
- 9 Center hitch on vehicle and Tighten all 1/2-13 GR5 fasteners with torque wrench to 75 Lb.-Ft. (102 N*M).
- 10 Apply sealant at carriage bolt attachments inside spare tire well to prevent the intrusion of water and exhaust fumes to vehicle interior.
- 11 Reattach plastic rivets to fascia. Replace spare tire and jack.

Note: check hitch frequently, making sure all fasteners and ball are properly tightened. If hitch is removed, plug all holes in trunk pan or other body panels to prevent entry of water and exhaust fumes. A hitch or ball which has been damaged should be removed and replaced. Observe safety precautions when working beneath a vehicle and wear eye protection. Do not cut access or attachment holes with a torch.

This product complies with safety specifications and requirements for connecting devices and towing systems of the state of New York, V.E.S.C. Regulation V-5 and SAE J684.