

Installation Instructions

Part Numbers:

24769

60832

77145

24732 U-Haul

Dodge Caliber

Except SRT4

(Sold separately)

Drawbar Kit:

3591

**Do Not Exceed Lower of Towing Vehicle
Manufacturer's Rating or**

2000 LB (908 Kg) Max Gross Trailer Weight

200 LB (90.8 Kg) Max Tongue Weight

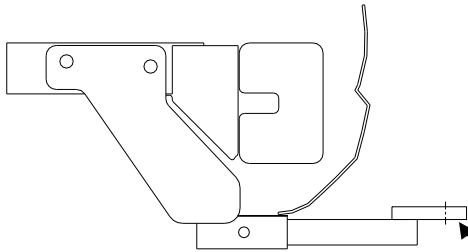

Drawbar must be used in the **Rise** position only.

Hitch Shown In Proper Position

Equipment Required:

Fastener Kit: 24769F

Wrenches: 15/16

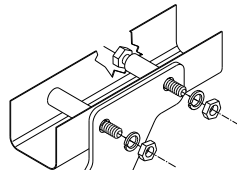

Fasteners typical both sides

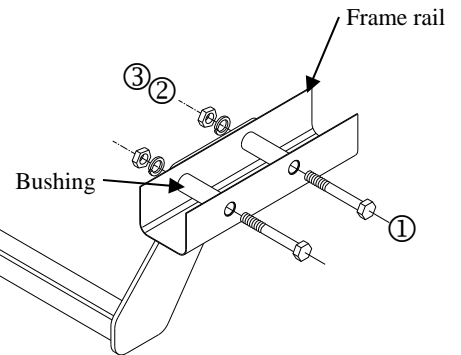

①	Qty. (4)	Hex Bolt 5/8-11 X 4	③	Qty. (4)	Hex Nut 5/8-11
②	Qty. (4)	Lock Washer 5/8			

1. Place 5/8 bolts into bushing from the outboard side of the frame rails. Leave flush with the inboard frame rail.
2. Raise hitch into position and push 5/8 bolts through brackets to support hitch.
3. Attached remaining fasteners as shown.

Tighten all 5/8-11 fasteners with torque wrench to 100 Lb.-Ft. (136 N*M)

Note: check hitch frequently, making sure all fasteners and ball are properly tightened. If hitch is removed, plug all holes in trunk pan or other body panels to prevent entry of water and exhaust fumes. A hitch or ball which has been damaged should be removed and replaced. Observe safety precautions when working beneath a vehicle and wear eye protection. Do not cut access or attachment holes with a torch.

This product complies with safety specifications and requirements for connecting devices and towing systems of the state of New York, V.E.S.C. Regulation V-5 and SAE J684.