

# Installation Instructions

## Honda Civic Including SI & Hybrid

Part Numbers:

**24763**

**77139**

**60822**

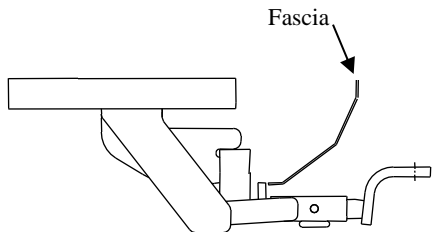

**(Sold separately)**  
**Drawbar Kit:**  
3593

Drawbar must be used in the **Rise** position only.

**Do Not Exceed Lower of Towing Vehicle  
Manufacturer's Rating or**

**2000 LB (908 Kg) Max Gross Trailer Weight**

**200 LB (90.8 Kg) Max Tongue Weight**

### Hitch Shown In Proper Position

#### Equipment Required:

**Fastener Kit:** 24763F

**Wrenches:** 3/4, 9/16, 10mm,

**Drill Bits:** 1/2 drill on some models required.



Drill to enlarge holes on inner layer of frame rails if necessary.

**Wiring Access Location:** PC3, PC4

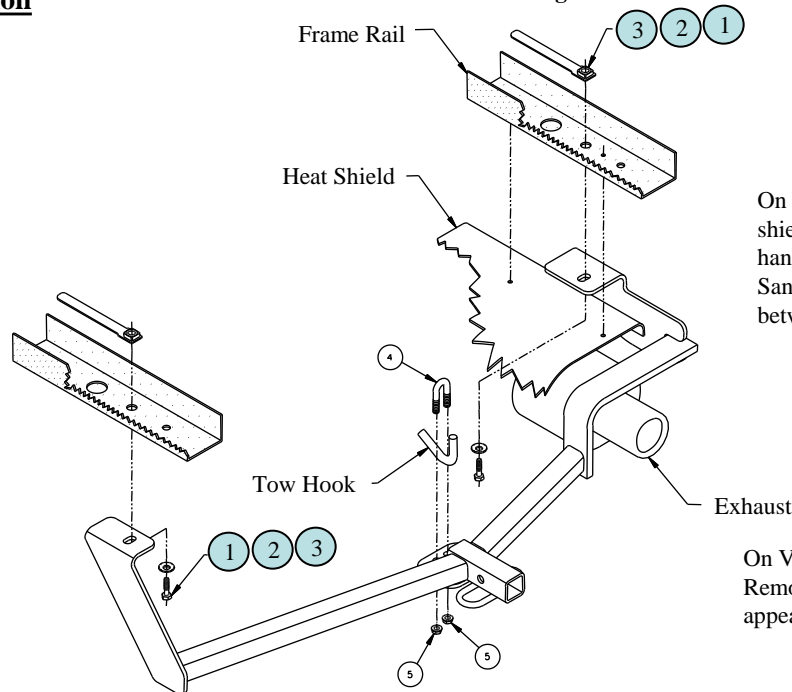

On Hybrid: Trim heat shield as required to allow handle nut to be installed. Sandwich heat shield between frame and hitch.

On Vehicles Equipped: Remove or trim plastic appearance panel.

1	Qty. (2)	1/2-13 Hex Bolt GR5	4	Qty. (1)	3/8-16 U-Bolt GR2
2	Qty. (2)	1/2 Conical Toothed Washer	5	Qty. (2)	3/8-16 Flanged Lock Nut
3	Qty. (2)	1/2-13 Handle Nut			

- Lower vehicle exhaust by removing tailpipe tangs out of rubber exhaust hanger at rear of vehicle.
- On the Passenger's side remove the (4) bolts that attach the exhaust heat shield to the vehicle. (Do not Discard).
- On the Driver's side, remove the plastic rivet and nut that hold the plastic shroud to the frame rail. (Do not Discard).
- Raise hitch into position with frame bracket flanges between the frame rail and plastic shroud on the Driver's side and between the frame rail and exhaust heat shield on the Passenger's side. **Make sure that tailpipe tangs are above hitch bar while raising hitch in to place.** On some vehicles it may be necessary to remove chrome decorative ring off of end of tailpipe to allow muffler to slide sideways toward middle of vehicle to allow better wrench access.
- Insert 1/2"-13 handle nuts through the large holes in vehicle frame rails and install fasteners as shown above.
- Insert the 3/8-16 U-bolt through the vehicle tow hook and insert through the mounting holes located on the hitch, (see above).
- Tighten all fasteners to the required torque specifications shown below.
- Reinstall exhaust heat shield over hitch Reattach exhaust to hanger & replace rivet and nut holding plastic shroud on Driver's side. Heat shield may require trimming. Reattach chrome decorative ring to tailpipe if removed.

Tighten all 3/8 fasteners with torque wrench to 20 Lb.-Ft. (27 N\*M)

Tighten all 1/2 fasteners with torque wrench to 50 Lb.-Ft. (68 N\*M)

Note: check hitch frequently, making sure all fasteners and ball are properly tightened. If hitch is removed, plug all holes in trunk pan or other body panels to prevent entry of water and exhaust fumes. A hitch or ball which has been damaged should be removed and replaced. Observe safety precautions when working beneath a vehicle and wear eye protection. Do not cut access or attachment holes with a torch.

This product complies with safety specifications and requirements for connecting devices and towing systems of the state of New York, V.E.S.C. Regulation V-5 and SAE J684.