

Installation Instructions

BUICK CENTURY, OLDSMOBILE INTRIGUE, PONTIAC GRAND PRIX

Part Numbers:

N24659

N77109

N60833

Drawbar Kit:

3592

(Sold separately)

Drawbar must be used in the **RISE** position only.

**Do Not Exceed Lower of Towing Vehicle
Manufacturer's Rating or**

2000 LB Max Gross Trailer Weight

200 LB Max Tongue Weight

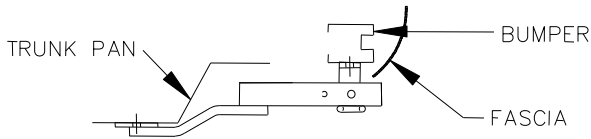

Hitch Shown In Proper Position

Equipment Required:

Fastener Kit: K24659

Wrenches: 7/8"

Drill Bits: 1/2"

Wiring Access Location: PC3, PC4

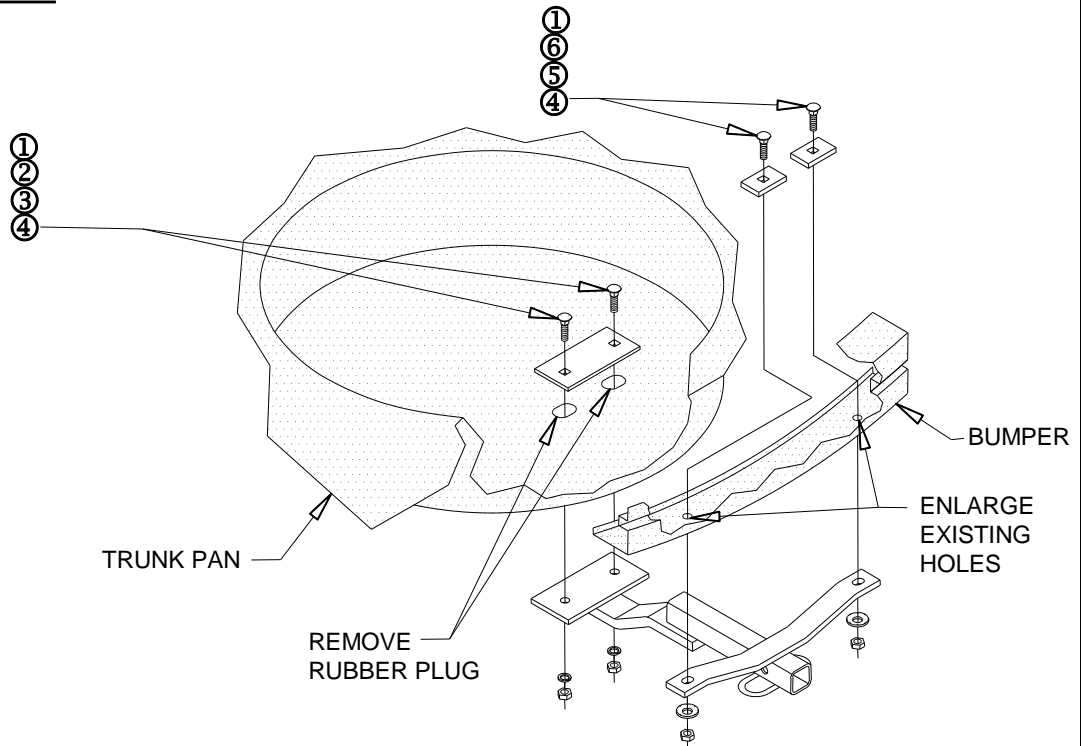

①	Qty. (4)	CARRIAGE BOLT 1/2"-13 X 1-3/4"	④	Qty. (4)	NUT 1/2"-13
②	Qty. (1)	BLOCK 1/4 X 2-1/2 X 6	⑤	Qty. (2)	CONICAL TOOTHED WASHER
③	Qty. (2)	LOCK WASHER - 1/2"	⑥	Qty. (2)	BLOCK 1/4" X 1-1/2" X 2"

1. ENLARGE EXISTING HOLES IN BUMPER TO 1/2".
2. REMOVE SPARE TIRE AND TRUNK PAN RUBBER PLUGS.
3. RAISE HITCH INTO POSITION AND ATTACH WITH FASTENERS AS SHOWN ABOVE.
4. SEAL HOLES IN TRUNK PAN TO PREVENT INTRUSION OF EXHAUST FUMES AND WATER.
5. REINSTALL SPARE TIRE.

Tighten all 1/2 fasteners with torque wrench to 75 Lb.-Ft. (102 N*M)

Note: check hitch frequently, making sure all fasteners and ball are properly tightened. If hitch is removed, plug all holes in trunk pan or other body panels to prevent entry of water and exhaust fumes. A hitch or ball which has been damaged should be removed and replaced. Observe safety precautions when working beneath a vehicle and wear eye protection. Do not cut access or attachment holes with a torch.

This product complies with safety specifications and requirements for connecting devices and towing systems of the state of New York, V.E.S.C. Regulation V-5 and SAE J684.