

INSTALLATION INSTRUCTIONS

N77026 VEHICLE

VOLKSWAGEN BEETLE
 VOLKSWAGEN GOLF
 VOLKSWAGEN CITY GOLF (CANADA ONLY)

EQUIPMENT REQUIRED:

WIRING ACCESS LOCATION: PC1, PC2

DRILL BITS: 1/2"

HITCH REQUIRES 1/2" PIN AND CLIP

WRENCHES: (TIGHTEN ALL FASTENERS WITH TORQUE WRENCH) 13mm, 7/8"

2000 LB MAX GROSS TRAILER WT
 200 LB MAX TONGUE WEIGHT
 DO NOT EXCEED TOWING VEHICLE RATINGS

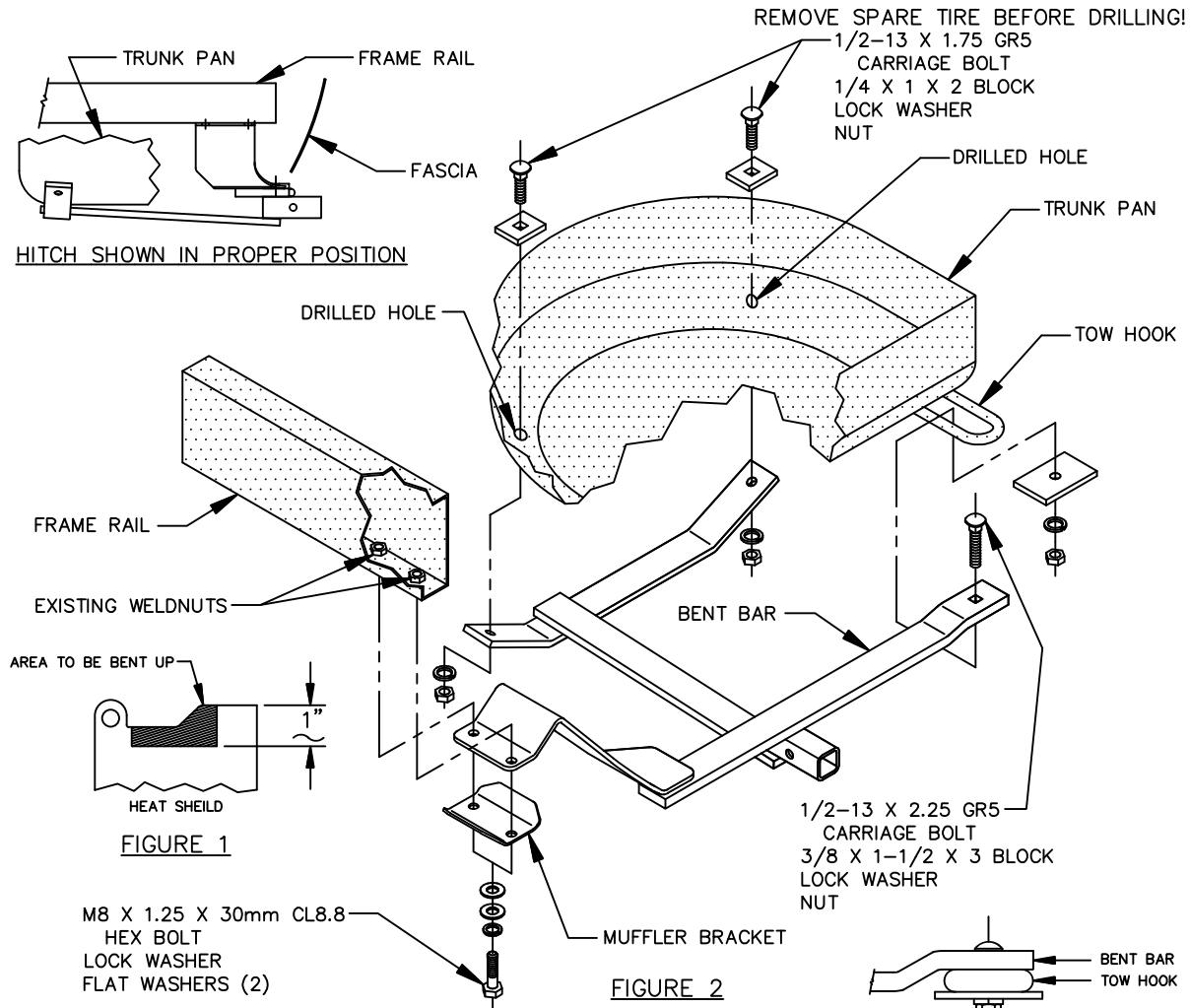

1. REMOVE SPARE TIRE FROM TRUNK
2. REMOVE (2) M8 FASTENERS HOLDING MUFFLER BRACKET TO FRAME RAIL.
3. BEND, APPROXIMATELY 1", OF REAR OF MUFFLER HEAT SHIELD UP. (SEE FIGURE 1)
4. POSITION HITCH ON VEHICLE, WITH BENT BAR ON TOP OF TOW HOOK. (SEE FIGURE 3)
5. SANDWICH HITCH SIDE BRACKET BETWEEN VEHICLE FRAME RAIL AND MUFFLER BRACKET. INSTALL NEW M8 FASTENERS AND WASHERS.
6. USING HITCH AS TEMPLATE, DRILL TWO (2) 1/2" HOLES IN TRUNK PAN.
7. INSTALL 1/2-13 BOLTS, BLOCKS, LOCK WASHERS AND NUTS AS SHOWN IN FIGURE 2.
8. SEAL HOLES DRILLED IN TRUNK PAN TO PREVENT INTRUSION OF EXHAUST FUMES AND WATER.
9. REINSTALL SPARE TIRE IN TRUNK.

TIGHTEN ALL 1/2 GR5 FASTENERS TO 75 LB-FT.
 TIGHTEN ALL M8 CL8.8 FASTENERS TO 20 LB-FT.

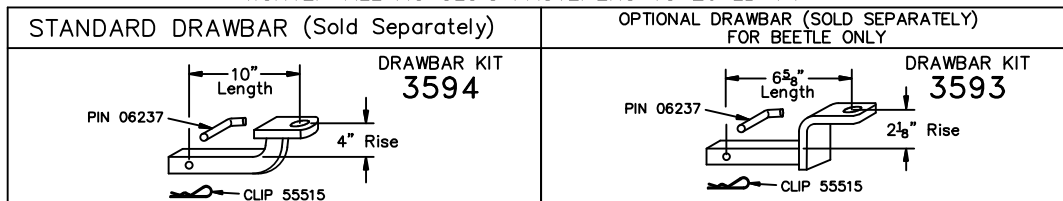

USE ONLY THE DRAWBAR SHOWN FOR CORRECT BUMPER CLEARANCE AND HEIGHT.
 DRAWBAR MUST BE USED IN THE RISE POSITION ONLY.

THIS PRODUCT COMPLIES WITH SAFETY SPECIFICATIONS AND REQUIREMENTS FOR CONNECTING DEVICES AND TOWING SYSTEMS OF THE STATE OF NEW YORK, V.E.S.C. REGULATION V-5 AND SAE J684.

APPROX WEIGHT (LB.) 27.5	FASTENER KIT K24679
-----------------------------	------------------------

NOTE: Check hitch frequently, making sure all fasteners and ball are properly tightened. If hitch is removed, plug all holes in trunk pan or other body panels to prevent entry of water and exhaust fumes. A hitch or ball which has been damaged should be removed and replaced. Observe safety precautions when working beneath a vehicle and wear eye protection. Follow car maker's specs for maximum trailer weight and tongue weight. Do not cut access or attachment holes with a torch.

Cequent Performance Products