

INSTALLATION INSTRUCTIONS

VEHICLE
HONDA CIVIC
ACURA 1.6 EL (CANADA ONLY)

HITCH NO.
24677
77025
60834

EQUIPMENT REQUIRED:

WIRING ACCESS LOCATION: PC3

DRILL BITS: NONE

HITCH REQUIRES 1/2" PIN AND CLIP

WRENCHES: (TIGHTEN ALL FASTENERS WITH TORQUE WRENCH) 9/16, 7/8

2000 LB MAX GROSS TRAILER WT
200 LB MAX TONGUE WEIGHT
DO NOT EXCEED TOWING VEHICLE RATINGS

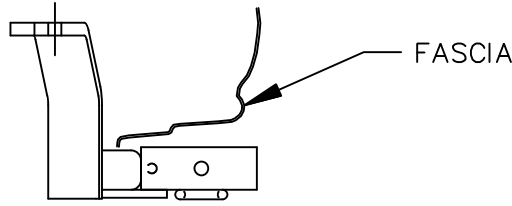

FASCIA

HITCH SHOWN IN PROPER POSITION

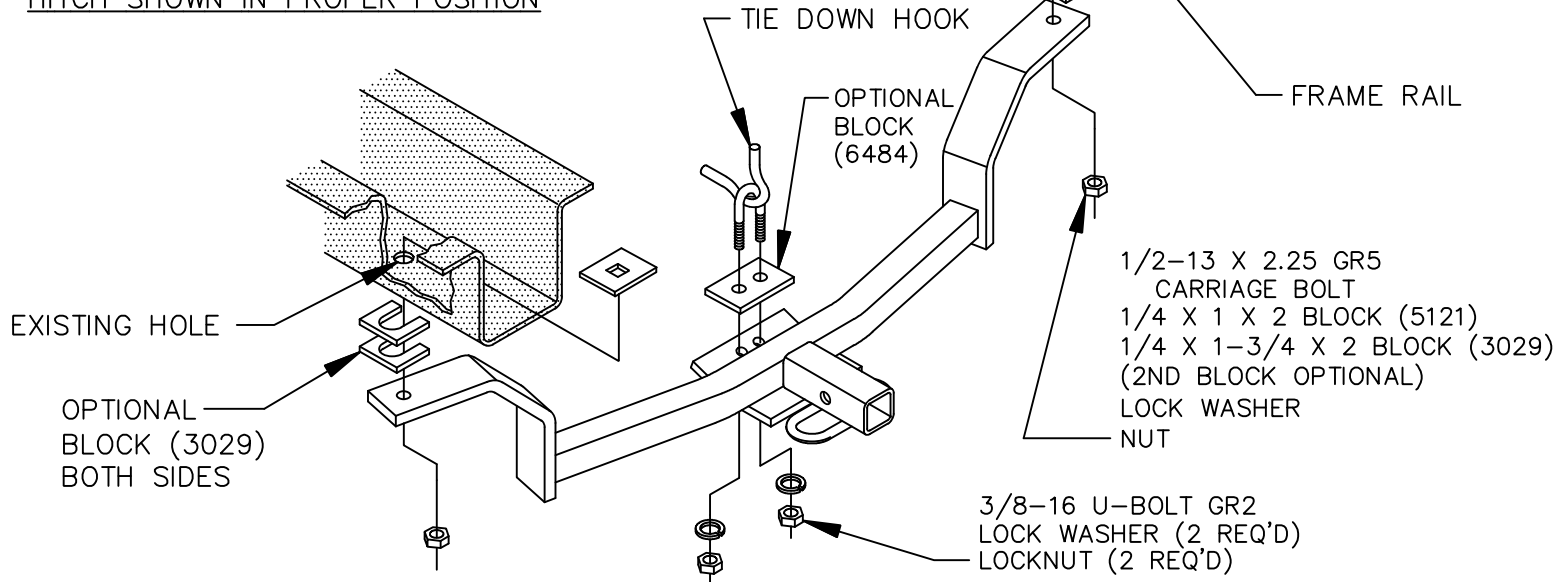

1. FISHWIRE CARRIAGE BOLT AND BLOCK (5121) THROUGH END OF FRAME RAIL AS SHOWN.
2. RAISE HITCH INTO POSITION AND LOOSELY INSTALL U-BOLT, LOCK WASHERS AND LOCKNUTS AS SHOWN.
3. INSERT 1/4 X 1-3/4 X 2 U-SHAPED BLOCK (3029) BETWEEN HITCH SIDE ARM AND VEHICLE FRAME, EACH SIDE. BE CAREFUL NOT TO SANDWICH AND CRUSH TURNED-DOWN EDGE OF FRAME HOLE. USE 2ND U-SHAPED BLOCK (3029) IF NEEDED SO THAT RECEIVER TUBE IS LEVEL OR TILTED SLIGHTLY UPWARD.
4. INSTALL 3/8" U-BOLT THROUGH TOW HOOK AND HITCH BRACKET AS SHOWN ABOVE. USE BLOCK (6484) IF NEEDED SO THAT RECEIVER TUBE IS LEVEL OR TILTED SLIGHTLY UPWARD.

TIGHTEN ALL 3/8 GR2 FASTENERS TO 20 LB.-FT.

TIGHTEN ALL 1/2 GR5 FASTENERS TO 75 LB.-FT.

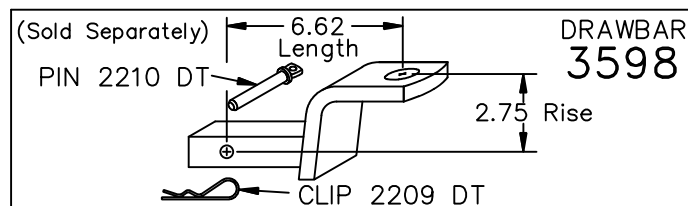

USE ONLY THE DRAWBAR SHOWN FOR CORRECT BUMPER CLEARANCE AND HEIGHT.
DRAWBAR MUST BE USED IN THE RISE POSITION ONLY.

THIS PRODUCT COMPLIES WITH SAFETY SPECIFICATIONS AND REQUIREMENTS FOR CONNECTING DEVICES AND TOWING SYSTEMS OF THE STATE OF NEW YORK AND V.E.S.C. REGULATION V-5.

APPROX WEIGHT (LB.)	FASTENER KIT
19.5	01131-135

NOTE: Check hitch frequently, making sure all fasteners and ball are properly tightened. If hitch is removed, plug all holes in trunk pan or other body panels to prevent entry of water and exhaust fumes. A hitch or ball which has been damaged should be removed and replaced. Observe safety precautions when working beneath a vehicle and wear eye protection. Follow car maker's specs for maximum trailer weight and tongue weight. Do not cut access or attachment holes with a torch.

Cequent Performance Products