



## 7018100 Canoe Loader Instructions

### READ, UNDERSTAND, FOLLOW AND SAVE THESE INSTRUCTIONS

- Read, understand and follow all instructions before installing and using this product.
- Never allow anyone unfamiliar with these instructions to use this product. Read, understand and follow all instructions provided by the manufacturer of the product(s) on which this product will be installed.
- Installation of this product must conform to the following mounting instructions.
- Save these instructions for use as a reference in the future.
- Never exceed the rated capacity of this Canoe Loader or any product that this Canoe Loader will be installed on. Canoe Loader rated capacity is 100 lb evenly distributed.
- When loading or unloading canoe, secure vehicle from rolling and/or moving.
- When use canoe loader in conjunction with the hitch ball, the adaptor plate must be used. Use of the adaptor plate may require a hitch ball with a longer threaded shank. A minimum of two (2) complete threads must be extended past the bottom of the hitch ball nut.
- This Canoe Loader is designed for vertical loads. Excessive side forces must be avoided.
- Operator must use caution never to position any part of your body under any portion of the canoe when loading or unloading. Property damage or serious bodily injury could result.
- While loading a canoe, the end loaded on the Canoe Loader must be secured before attempting to rotate the canoe into a transport position.
- While transporting a canoe, both ends of the canoe must be secured tightly to the vehicle to prevent disengagement from the vehicle. NOTE: Securing canoe to Canoe Loader only is not sufficient for transportation. Canoe must be directly secured to vehicle with rope or straps.
- When unloading a canoe, the end secured at the Canoe Loader must remain secured until the canoe is in a stable unload position.
- When loading/unloading, be careful not to contact vehicle with canoe, other than at intended surfaces.
- When loading/unloading, make sure that your path and the canoe's path of travel is level and free from any obstruction.
- Before each use of the Canoe Loader, make sure that all hardware is tightened appropriately.
- Follow all appropriate federal, state and local regulations for transporting canoes.

 **WARNING:** Failure to follow these warnings and instructions may result in property damage, serious bodily injury, and/or death.

Item	Description	Qty
1	Adaptor Plate	1
2	Receiver Tube	1
3	3/4-10 X 2.00 Square head bolt	1
4	3/4" Spring Lock Washer	1
5	3/4"-10 Hex Nut	1
6	Adjustment Tube	1
7	Lynch Pin	1
8	Tube End Cap	2
9	Cross Support Tube	1
10	Rubber Strip	2
11	Plastic Friction Disk	1
12	Upright Tube	1
13	Flat Washer	1
14	1/2-13 Locknut	1
15	5/16"-18 x 2.25" Hex Bolt	1
16	5/16"-18 Locknut	1
17	Shock Cord	1

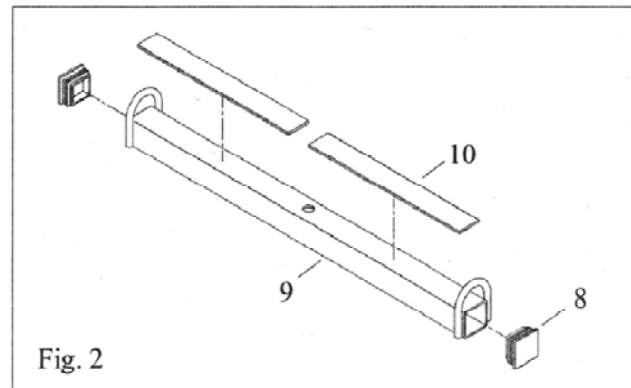
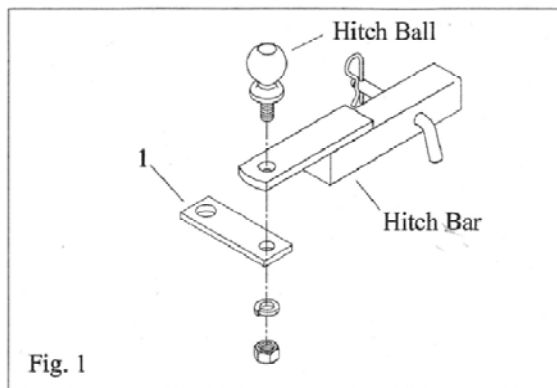
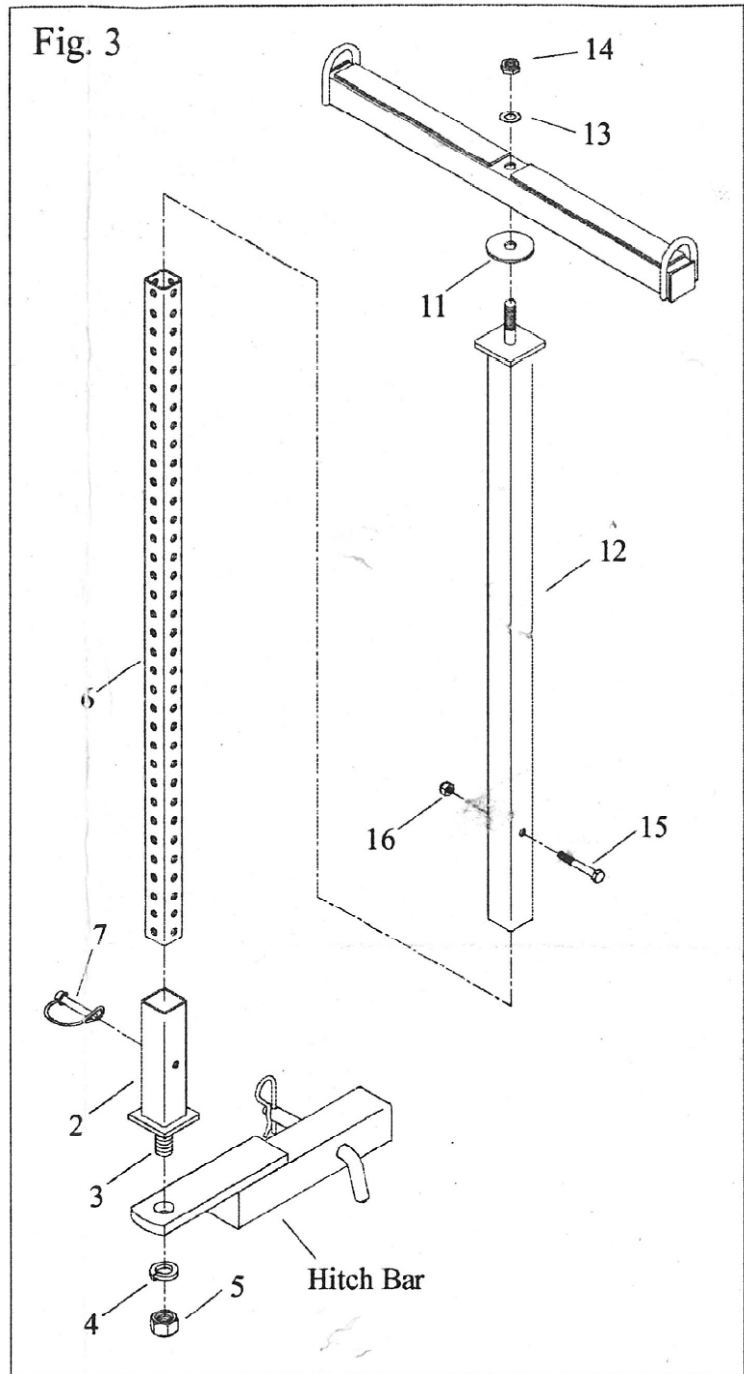

## **Mounting Instructions**

- Remove ball from trailer hitch. Determine if trailer hitch will be needed at the same time as the Canoe Loader. If hitch ball is needed, (see Fig. 1) place hitch ball into hitch, then slide adaptor plate (Item #1) under hitch, then install hitch ball lock washer and hitch ball hex nut. The adapter must be mounted parallel with the rear of the towing vehicle. Torque to 150 ft-lbs for hitch balls with  $\frac{3}{4}$ " threads and 200 ft-lbs for hitch balls with 1" threads.
- If hitch ball is not needed (see Fig. 3), install hitch receiver tube (Item #2) directly into hitch bar.
- Place  $\frac{3}{4}$ " square-head bolt (Item #3) into hitch receiver tube (Item #2) and through hitch bar or adapter plate (Item #1). Then install lock washer (Item #4) and  $\frac{3}{4}$ " locknut (Item #5). Torque to 150 ft-lbs.
- Slide adjustment tube (Item #6) into hitch receiver tube (Item #2) and secure with lynch pin (Item #7).
- See Fig. 2. Insert plastic tube end caps (Item #8) into cross support tube (Item #9). Apply rubber strips (Item #10) to cross support tube as shown. Tube must be clean and dry before applying strips. Use firm and equal pressure.
- See Fig. 3. Place plastic friction disk (Item #11) over the  $\frac{1}{2}$ " bolt that is welded to the upright tube (Item #12). Then place cross support tube (with rubber protective strip) on the  $\frac{1}{2}$ " bolt above the friction disk. Install flat washer (Item #13) and  $\frac{1}{2}$ " locknut (Item #14). Tighten snugly. Cross support tube must not free spin. If moderate force is not required to spin the cross support tube, tighten the nut another  $\frac{1}{4}$  turn. Repeat until spinning of the cross support tube requires moderate force.
- Place upright/cross support tube over adjustment tube.
- Determine proper mounting height. When loaded on Canoe Loader, no part of canoe should contact the vehicle.
- Once proper mounting height has been determined, align the nearest holes in the tubes and insert the  $\frac{5}{16}$ " hex bolt (Item #15). Install the  $\frac{5}{16}$ " locknut (Item #16). Tighten securely.

## Operating Instructions

### TO LOAD A CANOE (canoe must be loaded upside-down)

1. Load a secure one end of the canoe onto the cross support tube of the Canoe Loader. Use the loops on the end of the cross support tube for attaching shock cord (Item #17) around canoe. NOTE: Rear of canoe must be directly secured to the vehicle after canoe is resting on vehicle's top support(s) and front end is secured (see step 4).
2. After canoe is secured onto the cross support tube, make sure your path of travel, as well as the canoe's path of travel, are free from any obstructions. Then, lift canoe above top of loading vehicle and rotate the canoe towards the front of the loading vehicle. Rest canoe on a suitable roof support towards front of vehicle.
3. Once canoe is resting on front support, secure front of the canoe. This is typically done by securing canoe to vehicle using rope or strap.
4. After front end is secure, the rear must also be secured to the vehicle. This is typically done by securing canoe to the vehicle using rope or strap. It is also recommended than an additional ratchet type strap or rope be used around the center of the canoe.
5. As necessary, tie a red flag to the furthestmost end of the canoe.

### TO UNLOAD A CANOE (DO NOT attempt to unload the canoe by freeing the rear of the canoe first. Always start from the front end.)

1. Make sure your path of travel, as well as the canoe's path of travel, are free from any obstructions. Then, free the front end of the canoe. Free rear end of canoe from vehicle. NOTE: Canoe must remain secured to Canoe Loader until the front end of the canoe is resting on the ground.
2. Next, rotate canoe towards rear of vehicle and rest canoe on the ground.
3. Free rear of canoe from support bar of Canoe Loader and slowly remove the canoe.