

Installation Instructions

Jeep Grand Cherokee

Part Numbers:
51195

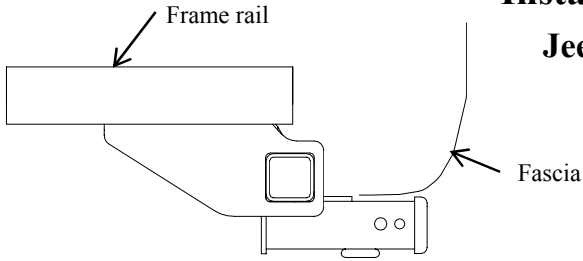

**Do Not Exceed Lower of Towing Vehicle
Manufacturer's Rating or**

Hitch type	Max Gross Trailer WT (LB)	Max Tongue WT (LB)
Weight Distributing	7500 (3405 Kg)	750 (341 Kg)
Weight Carrying Ball Mount	5000 (2270 Kg)	500 (227 Kg)

Hitch Shown In Proper Position

Equipment Required:

Fastener Kit: 51195F

Wrenches: 21mm

Wiring Access Location: TBD

Note: Fasteners typical both sides

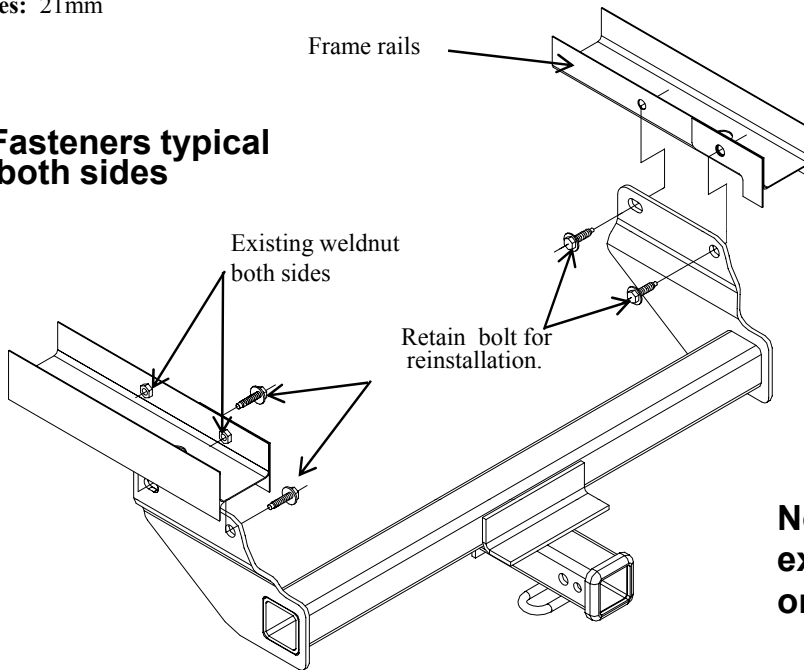

Note: Uses all existing Bolts on Vehicle

1. Remove (4) existing M14 bolts (Do Not clean the threads). Retain bolt for reinstallation.
2. Raise hitch into position as shown and install fasteners as shown. If excess caulking on the frame rail interferes with hitch installation lower hitch and scrape excess caulking for installation.
3. Tighten all fasteners to called-out torque specification.

Tighten all M14 fasteners with torque wrench to 115 Lb.-Ft. (156 N*M)

Note: check hitch frequently, making sure all fasteners and ball are properly tightened. If hitch is removed, plug all holes in trunk pan or other body panels to prevent entry of water and exhaust fumes. A hitch or ball which has been damaged should be removed and replaced. Observe safety precautions when working beneath a vehicle and wear eye protection. Do not cut access or attachment holes with a torch.

This product complies with safety specifications and requirements for connecting devices and towing systems of the state of New York, V.E.S.C. Regulation V-5 and SAE J684.