

INSTALLATION INSTRUCTIONS

44529N VEHICLE

NISSAN XTERRA

EQUIPMENT REQUIRED:

WIRING ACCESS LOCATION: SUV1, SUV2

DRILL BITS: NONE

HITCH REQUIRES 5/8" PIN AND CLIP IF STABILIZING PIN IS NOT INSTALLED.

WRENCHES: (TIGHTEN ALL FASTENERS WITH TORQUE WRENCH) 18mm, 19mm

DO NOT EXCEED LOWER OF
TOWING VEHICLE MFR'S RATINGS OR

HITCH TYPE ▼	MAX GROSS TRLR WT(LB)	MAX TONGUE WT(LB)
WEIGHT DISTRIBUTING	5500	550
WEIGHT CARRYING BALL MOUNT	3500	350

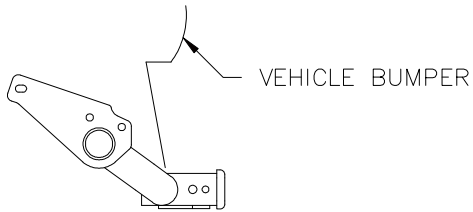

VEHICLE BUMPER

HITCH SHOWN IN PROPER POSITION

FASTENERS TYPICAL BOTH
SIDES OF VEHICLE

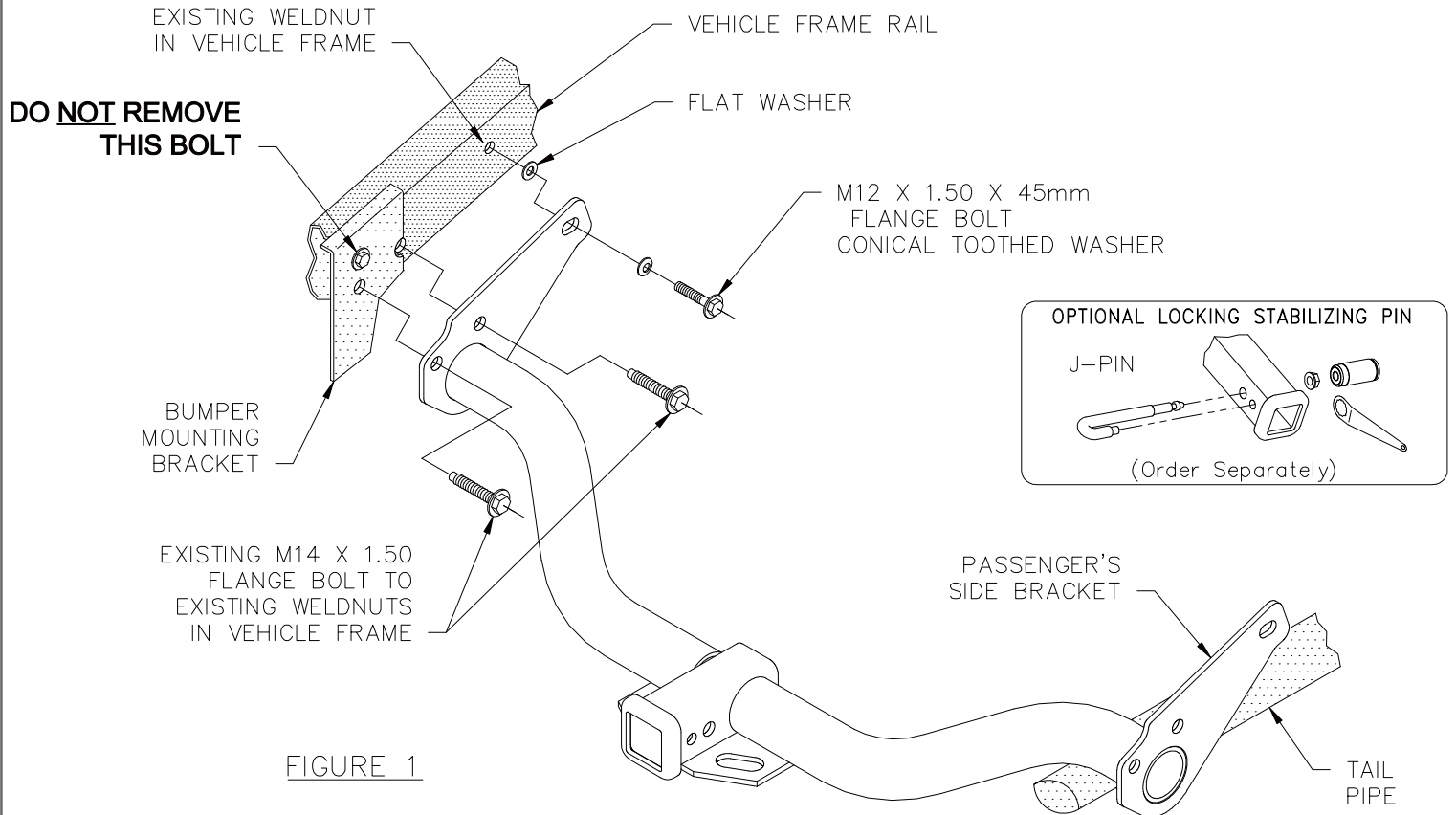

FIGURE 1

1. LOWER SPARE TIRE.
2. REMOVE (2) M14 BOLTS, EACH SIDE WHICH ATTACH BUMPER MOUNTING BRACKETS TO FRAME (SEE FIGURE 1). RETAIN BOLTS FOR HITCH INSTALLATION.
3. RAISE HITCH BY FIRST LIFTING PASSENGER'S SIDE BRACKET OVER EXHAUST PIPE AND THEN LIFTING DRIVER'S SIDE BRACKET UP INTO POSITION. SECURE WITH M14 FLANGE BOLTS REMOVED IN STEP 2.
NOTE: IT MAY EASE INSTALLATION TO LOWER EXHAUST BY REMOVING (3) EXHAUST HANGER BOLTS FROM EXHAUST HANGER BRACKET.
4. AT FORWARD ATTACHMENT, BOTH SIDES, PLACE 1/2" FLAT WASHER BETWEEN VEHICLE FRAME AND HITCH SIDE BRACKET. SECURE WITH CONICAL TOOTHED WASHER AND M12 BOLT (PROVIDED WITH HITCH) AS SHOWN.
TIGHTEN M12 BOLTS TO 68 LB.-FT.
TIGHTEN M14 BOLTS TO 75 LB.-FT.
5. RAISE SPARE TIRE BACK INTO POSITION.

THIS PRODUCT COMPLIES WITH SAFETY SPECIFICATIONS AND REQUIREMENTS FOR CONNECTING DEVICES AND TOWING SYSTEMS OF THE STATE OF NEW YORK, V.E.S.C. REGULATION V-5 AND SAE J684.

APPROX WEIGHT (LB.)	FASTENER KIT
28	75291F

NOTE: Check hitch frequently, making sure all fasteners and ball are properly tightened. If hitch is removed, plug all holes in trunk pan or other body panels to prevent entry of water and exhaust fumes. A hitch or ball which has been damaged should be removed and replaced. Observe safety precautions when working beneath a vehicle and wear eye protection. Follow car maker's specs for maximum trailer weight and tongue weight. Do not cut access or attachment holes with a torch.

TOWING PRODUCTS