

# INSTALLATION INSTRUCTIONS

EQUIPMENT REQUIRED:

WIRING ACCESS LOCATION: SUV1, SUV2 OR PC3, PC4

DRILL BITS: NONE

HITCH REQUIRES 5/8" PIN AND CLIP IF STABILIZING PIN IS NOT INSTALLED.

WRENCHES: (TIGHTEN ALL FASTENERS WITH TORQUE WRENCH) 3/4, 10mm, 13mm 15mm

44525N VEHICLE

FORD FREESTYLE/TAURUS X  
FORD FIVE HUNDRED/TAURUS  
MERCURY MONTEGO/SABLE

DO NOT EXCEED LOWER OF  
TOWING VEHICLE MFR'S RATINGS OR

HITCH TYPE ▼	MAX GROSS TRLR WT(LB)	MAX TONGUE WT(LB)
WEIGHT DISTRIBUTING	4000	400
WEIGHT CARRYING BALL MOUNT	3500	350

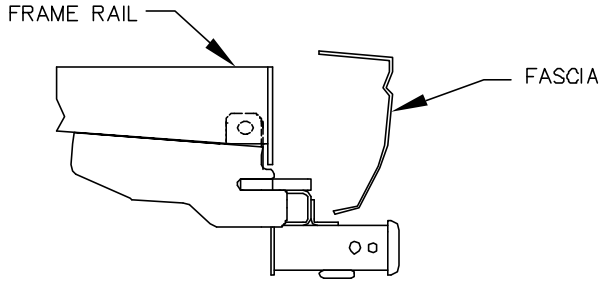

HITCH SHOWN IN PROPER POSITION

NOTE:  
KEEP BOLT AND BLOCK  
INSIDE FRAME UNTIL  
HITCH IS IN POSITION

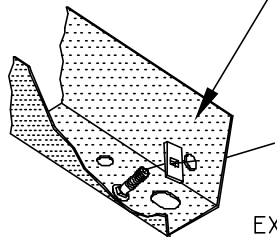

FIGURE 2.  
END VIEW DRIVER'S SIDE

SEE NOTE BELOW IF YOU HAVE  
A LATER MODEL 2009 VEHICLE  
FOR PASSENGER SIDE

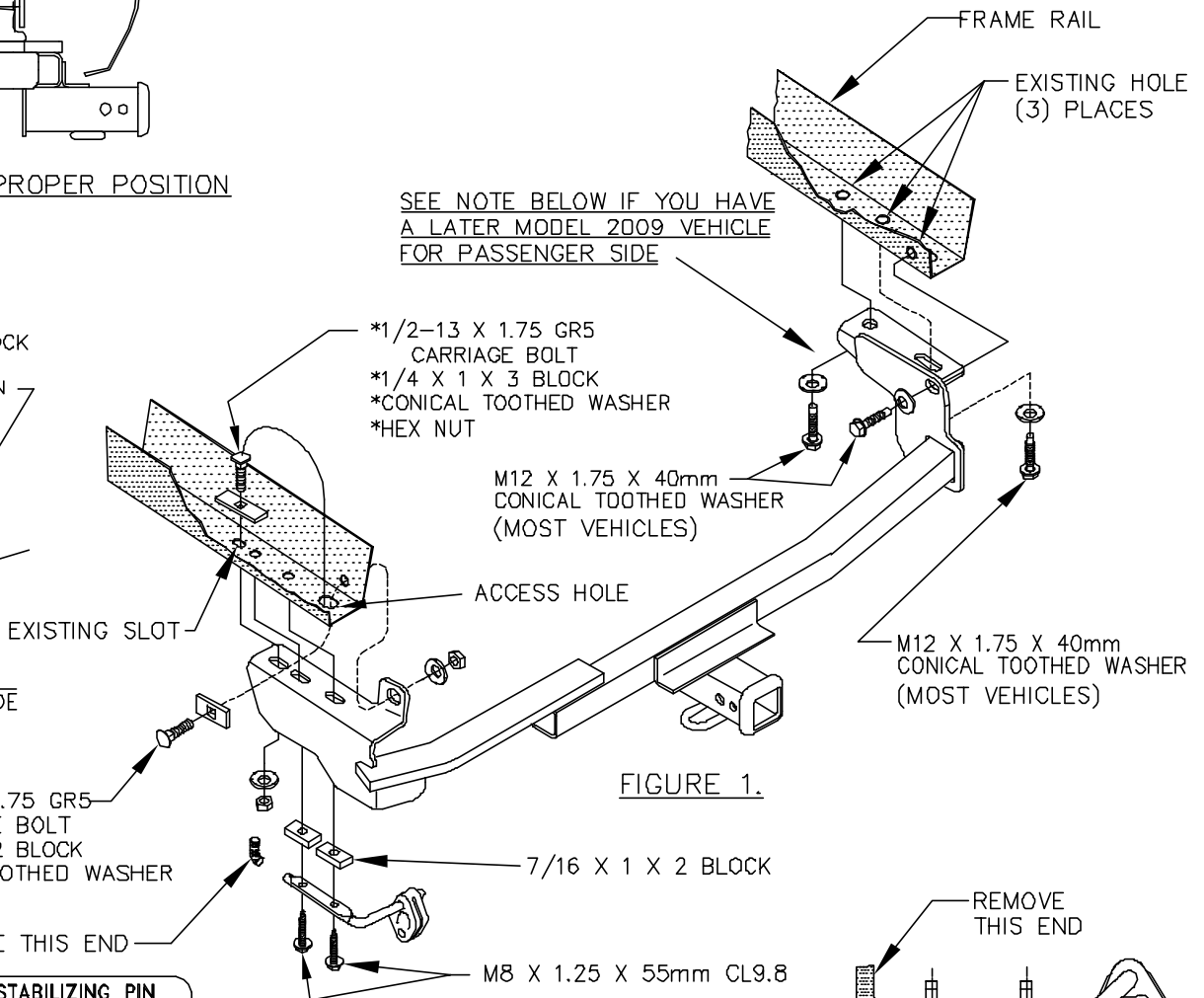

FIGURE 1.

\*1/2-13 X 1.75 GR5  
CARRIAGE BOLT  
\*1/4 X 1 X 2 BLOCK  
\*CONICAL TOOTHED WASHER  
\*HEX NUT

REMOVE THIS END

### OPTIONAL LOCKING STABILIZING PIN

J-PIN

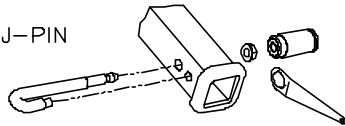

(Order Separately)

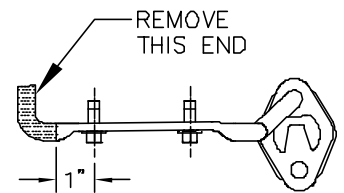

FIGURE 3.  
EXHAUST HANGER

**NOTE!** LATER MODEL 2009 VEHICLES DO NOT HAVE THE UNTHREADED WELDNUTS ON THE PASSENGER SIDE. IF YOU HAVE A LATER MODEL 2009 VEHICLE YOU NEED TO INSTALL THE FASTENERS IDENTIFIED WITH AN ASTERISK (\*) ON THE PASSENGER'S SIDE OF THE VEHICLE FRAME ALSO.

1. REMOVE THE EXHAUST HANGER BRACKET FROM THE DRIVER'S SIDE FRAME RAIL AND LOWER CARBON CANISTER ON THE PASSENGER SIDE (IF PRESENT).
2. FISHWIRE CARRIAGE BOLT(S) AND 1/4 X 1 X 3 BLOCK(S) THROUGH ACCESS HOLE(S) AT END OF FRAME AND INTO EXISTING SLOT(S) IN BOTTOM OF FRAME. REMOVE FISHWIRE.
3. FISHWIRE CARRIAGE BOLT(S) AND 1/4 X 1 X 2 BLOCK(S) THROUGH ACCESS HOLE(S) AT END OF FRAME. KEEP BOLT(S) AND BLOCK(S) INSIDE FRAME UNTIL HITCH IS IN POSITION. LEAVE FISHWIRE(S) ON CARRIAGE BOLT(S) TEMPORARILY, FIGURE 2.
4. RAISE HITCH INTO POSITION. USE FISHWIRE(S) TO PULL CARRIAGE BOLT(S) THROUGH HOLE(S) IN HITCH BRACKET(S) ON DRIVER'S \*(OR BOTH) SIDES. LOOSELY INSTALL CONICAL TOOTHED WASHER(S) AND HEX NUT(S) ONTO CARRIAGE BOLT(S).
5. ON ALL BUT LATER MODEL 2009'S INSTALL THREE (3) 12mm THREAD FORMING BOLTS AND CONICAL TOOTHED WASHERS INTO EXISTING UNTHREADED WELDNUTS ON PASSENGER SIDE AS SHOWN. BOLTS WILL FORM THREADS.
6. CUT OFF THE END OF THE EXHAUST HANGER THAT EXTENDS INTO THE FRAME. SEE FIGURE 3.
7. REATTACH THE EXHAUST HANGER WITH THE (2) TWO M8 X 1.25 X 55mm BOLTS AND 7/16 SPACER BLOCKS AND REATTACH THE CARBON CANISTER REMOVED IN STEP 1.

TIGHTEN ALL M8 CL9.8 FASTENERS TO 25 LB-FT, ALL M12 TO 92 LB-FT & ALL 1/2-13 TO 75 LB-FT.

THIS PRODUCT COMPLIES WITH SAFETY SPECIFICATIONS AND REQUIREMENTS FOR CONNECTING DEVICES AND TOWING SYSTEMS OF THE STATE OF NEW YORK, V.E.S.C. REGULATION V-5 AND SAE J684.

APPROX WEIGHT (LB.)	FASTENER KIT
42	75299F

NOTE: Check hitch frequently, making sure all fasteners and ball are properly tightened. If hitch is removed, plug all holes in trunk pan or other body panels to prevent entry of water and exhaust fumes. A hitch or ball which has been damaged should be removed and replaced. Observe safety precautions when working beneath a vehicle and wear eye protection. Follow car maker's specs for maximum trailer weight and tongue weight. Do not cut access or attachment holes with a torch.

**TOWING PRODUCTS**