

Hitch Shown In Proper Position

Equipment Required: Hacksaw, Pliers, Fishwire (provided)

Fastener Kit: 01131-047

Wrenches: 5/8, 11/16, 3/4, 7/8

Drill Bits: None

**Do Not Exceed Lower of Towing Vehicle
Manufacturer's Rating or**

Hitch type	Max Gross Trailer WT (LB)	Max Tongue WT (LB)
Weight Distributing	10,000 (4540 Kg)	1000 (454 Kg)
Weight Carrying Ball Mount	5000 (2270 Kg)	500 (227 Kg)

Wiring Access Location: SUV5

Note: cannot be installed on 1987 thru 1997 vehicles with factory step bumpers unless step bumper and its mounting brackets are permanently removed and standard factory bumper is installed.

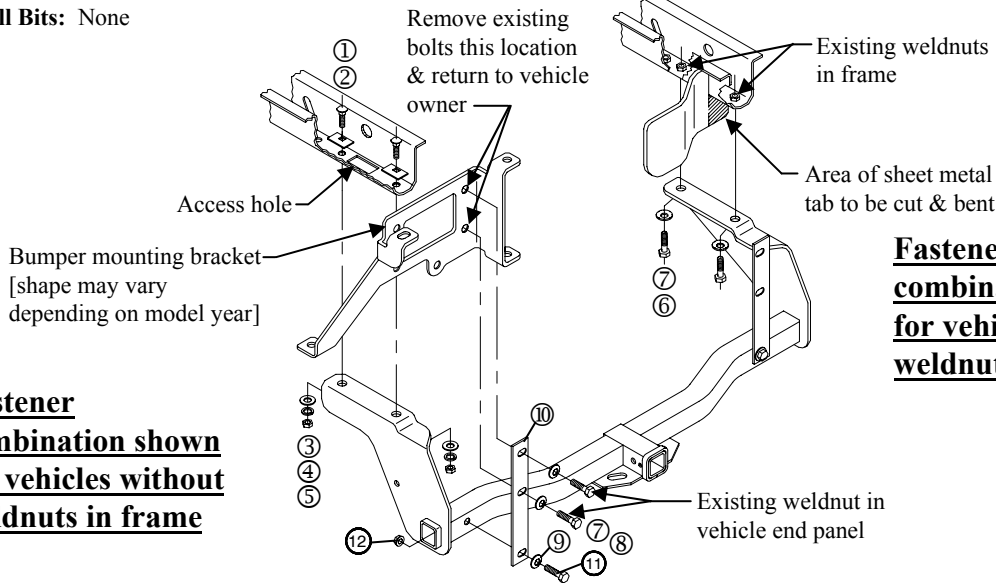

Fastener combination shown for vehicles without weldnuts in frame

Fastener combination shown for vehicles with weldnuts in frame

①	Qty. (4)	Carriage Bolt 1/2-13 X 1.75	⑦	Qty. (4)	Conical Washer 7/16
②	Qty. (4)	Block	⑧	Qty. (4)	Hex Bolt 7/16-14 X 1.25
③	Qty. (4)	Flat Washer Hardened 1/2	⑨	Qty. (2)	Conical Washer 1/2
④	Qty. (4)	Lock Washer 1/2	⑩	Qty. (2)	Bracket
⑤	Qty. (4)	Hex Nut 1/2-13	⑪	Qty. (2)	Hex Bolt 1/2-20 X 1.50
⑥	Qty. (4)	Hex Bolt M12 X 1.75 X 45	⑫	Qty. (2)	Flanged Locknut 1/2-20

For Step Bumper application – 1998 and later:

- Loosen two (2) outside bumper bracket bolts on face of bumper.
- Remove three (3) retaining bolts (bumper to bumper bracket) and rotate step bumper rearward.

Caution: Wiring harness is located inside passenger's side frame rail. Do not sandwich wires between frame rail and fasteners.

Note: If vehicle has heat shield, remove one (1) screw from bottom of frame rail so that bracket will sit flat on bottom of frame rail. Return screw to vehicle owner.

For all applications:

- Remove two (2) inboard bolts on bumper mounting bracket, each side, as indicated above. Return bolts to vehicle owner. Cut sheet metal tab, each side as indicated above. Bend tabs out of the way to provide clearance for hitch side brackets.

- Fishwire fasteners thru access hole as shown above.

Note: Vehicle with weldnuts in frame, install M12 hex bolts and conical washers as shown above.

- Raise hitch into position and install remaining fasteners as shown above. Reinstall step bumper.

Tighten all 7/16-14 GR5 fasteners with torque wrench to 50 Lb.-Ft. (68 N*M)

Tighten all 1/2-13 GR5 fasteners with torque wrench to 75 Lb.-Ft. (102 N*M)

Tighten all 1/2-20 GR5 fasteners with torque wrench to 55 Lb.-Ft. (75 N*M)

Tighten all M12 CL10.9 fasteners with torque wrench 92 Lb.-Ft. (125 N*M)

Note: check hitch frequently, making sure all fasteners and ball are properly tightened. If hitch is removed, plug all holes in trunk pan or other body panels to prevent entry of water and exhaust fumes. A hitch or ball which has been damaged should be removed and replaced. Observe safety precautions when working beneath a vehicle and wear eye protection. Do not cut access or attachment holes with a torch.

This product complies with safety specifications and requirements for connecting devices and towing systems of the state of New York, V.E.S.C. Regulation V-5 and SAE J684.