



INSTALLATION INSTRUCTIONS

Product No.

MULTI-FIT PICK-UP

37094

SMALL PARTS
PACKAGE 37424

SOLON, OHIO

WARNING: DO NOT LUBRICATE THREADS, BOLT FAILURE MAY OCCUR DUE TO OVER TIGHTENING.

WARNING: DO NOT DRILL OR WELD TO THIS HITCH.

IMPORTANT NOTES

USE ONLY REESE SUPPLIED OR APPROVED BOLTS, LOCKNUTS, AND WASHERS TO INSTALL THIS HITCH

TOOLS REQUIRED

5/8"	DRILL BIT
15/16"	SOCKET
15/16"	WRENCH
3/4"	SOCKET
3/4"	WRENCH
2	CLAMPS
	TORQUE WRENCH

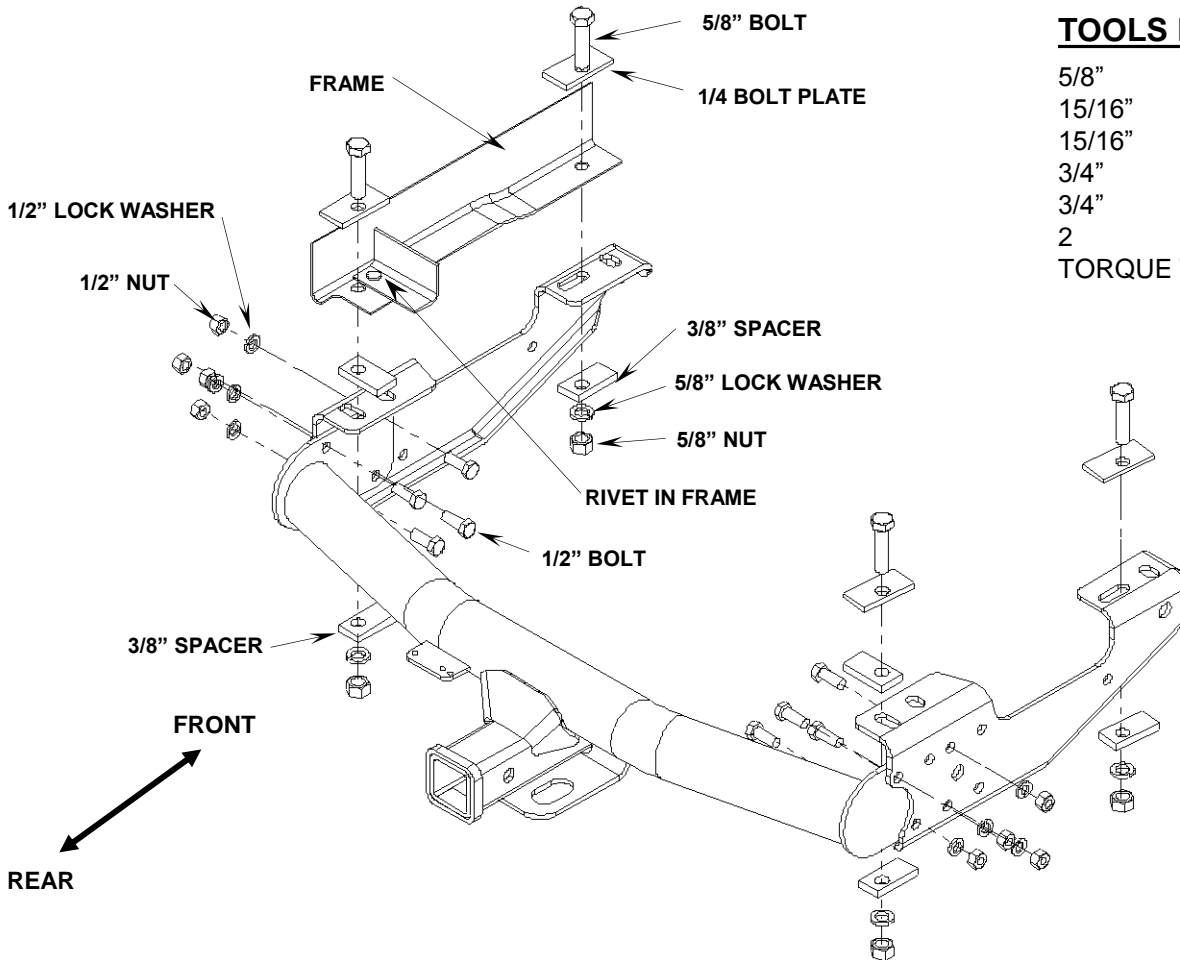

1973-1996 Ford Full Size Pickup & 1997 F-250 Heavy Duty / F-350 Heavy Duty:

1. Assemble the three pieces of the hitch together on the floor before attaching it to the truck. Using 1/2" bolts, lock washers and nuts, bolt the brackets to the center section as shown. Place the brackets on the outside of the center section. Bolt through the holes shown in the illustration. Leave the bolts loose enough to center brackets on truck frame. **NOTE:** Be sure to use four holes to bolt each bracket to the center section.
2. Clamp the hitch to the frame with a 3/8" thick spacer between the hitch and the frame at the rear. Align the ends of the brackets with the end of the frame as shown.
3. Using the holes in the bracket as a guide, drill 5/8" diameter holes into the frame at the locations shown.
4. Insert 5/8" bolts with bolt plates down through the frame and into the bracket. Place a 3/8" thick spacer between the frame and the bracket at the rear mounting hole. Install a 3/8" thick spacer, lock washer and nut on each bolt.
5. Tighten the nuts in the following order: First torque the 1/2" nuts to 70 ft•lb. Then torque the 5/8" nuts to 115 ft•lb.

NOTE: SIDE BRACKETS WILL DEFLECT WHEN TIGHTENED

TOOLS REQUIRED

15/16" SOCKET
15/16" WRENCH
3/4" SOCKET
3/4" WRENCH
5/8" DRILL BIT
TORQUE WRENCH

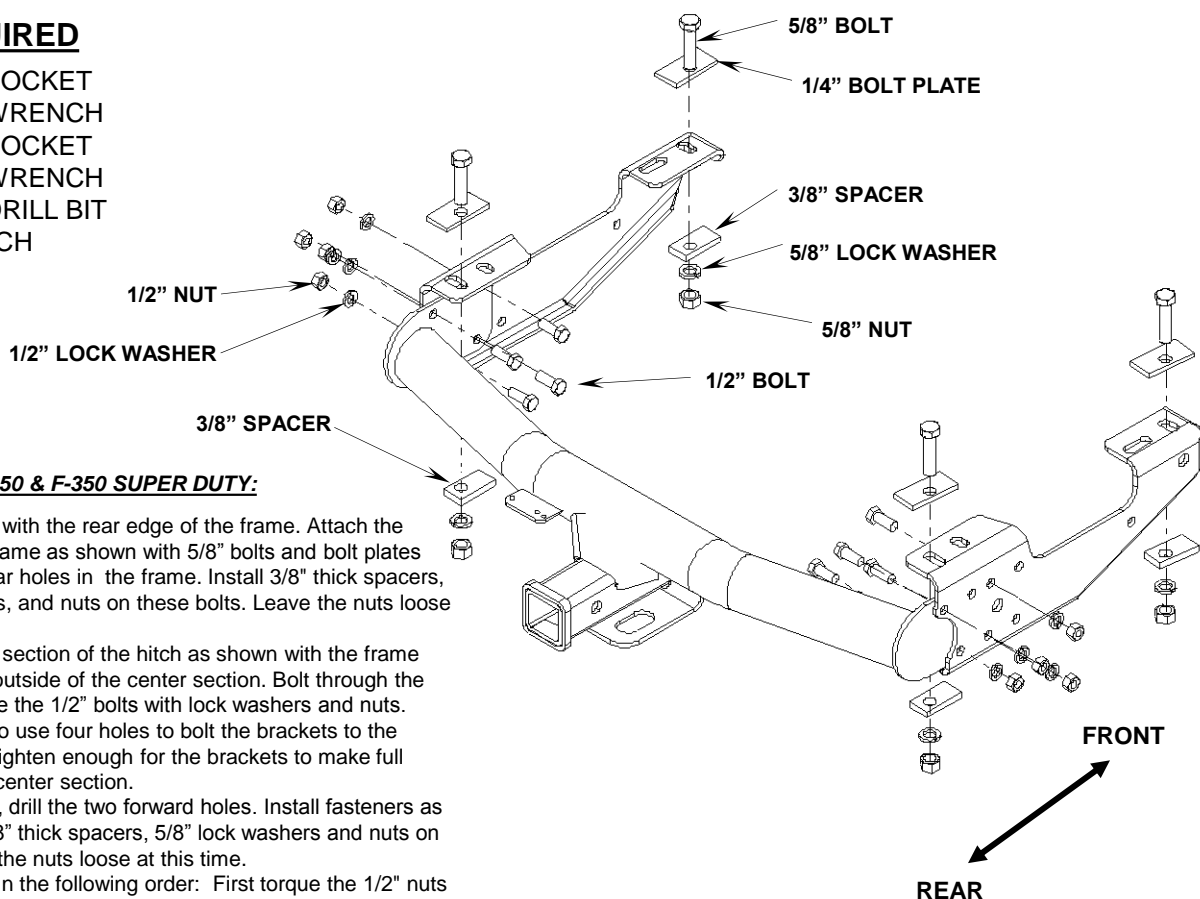

TOOLS REQUIRED

15/16" SOCKET
15/16" WRENCH
3/4" SOCKET
3/4" WRENCH
TORQUE WRENCH

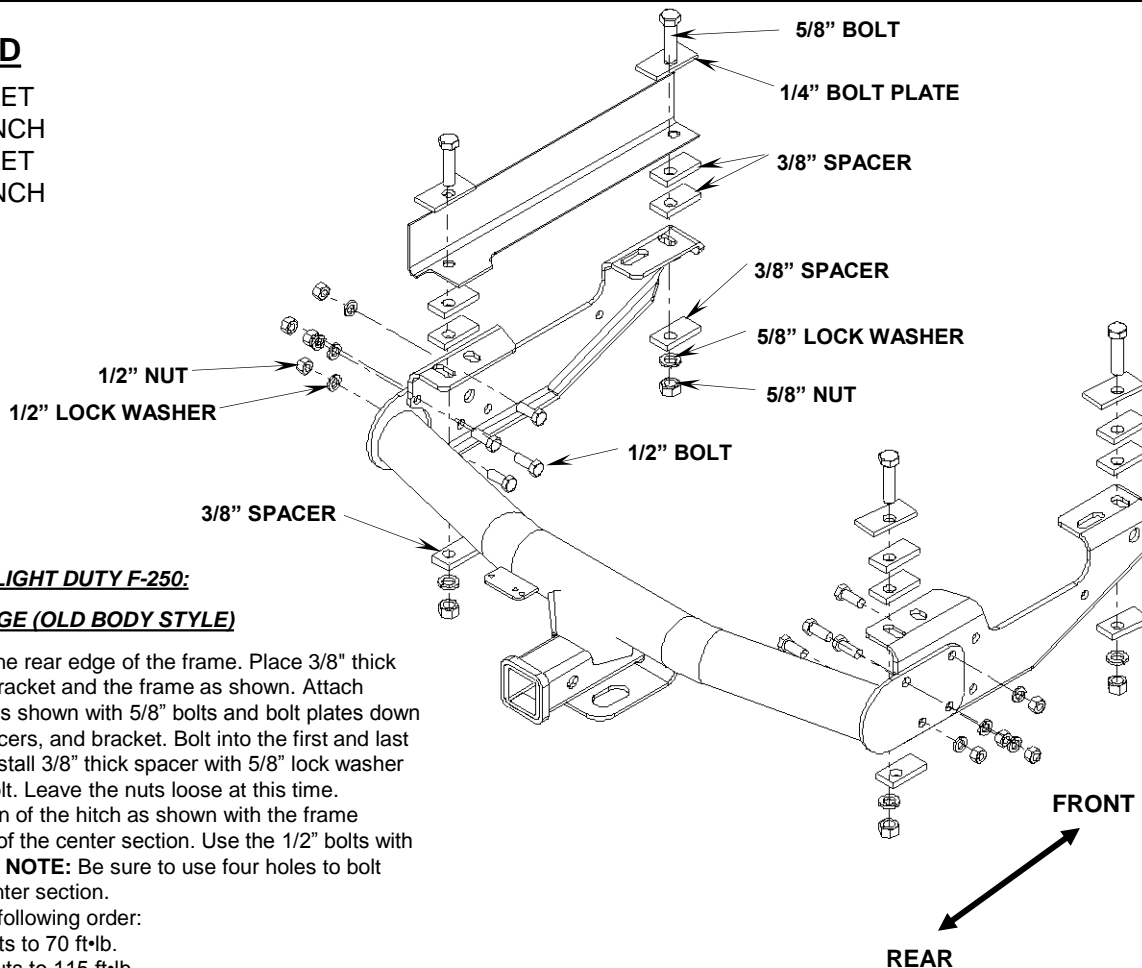

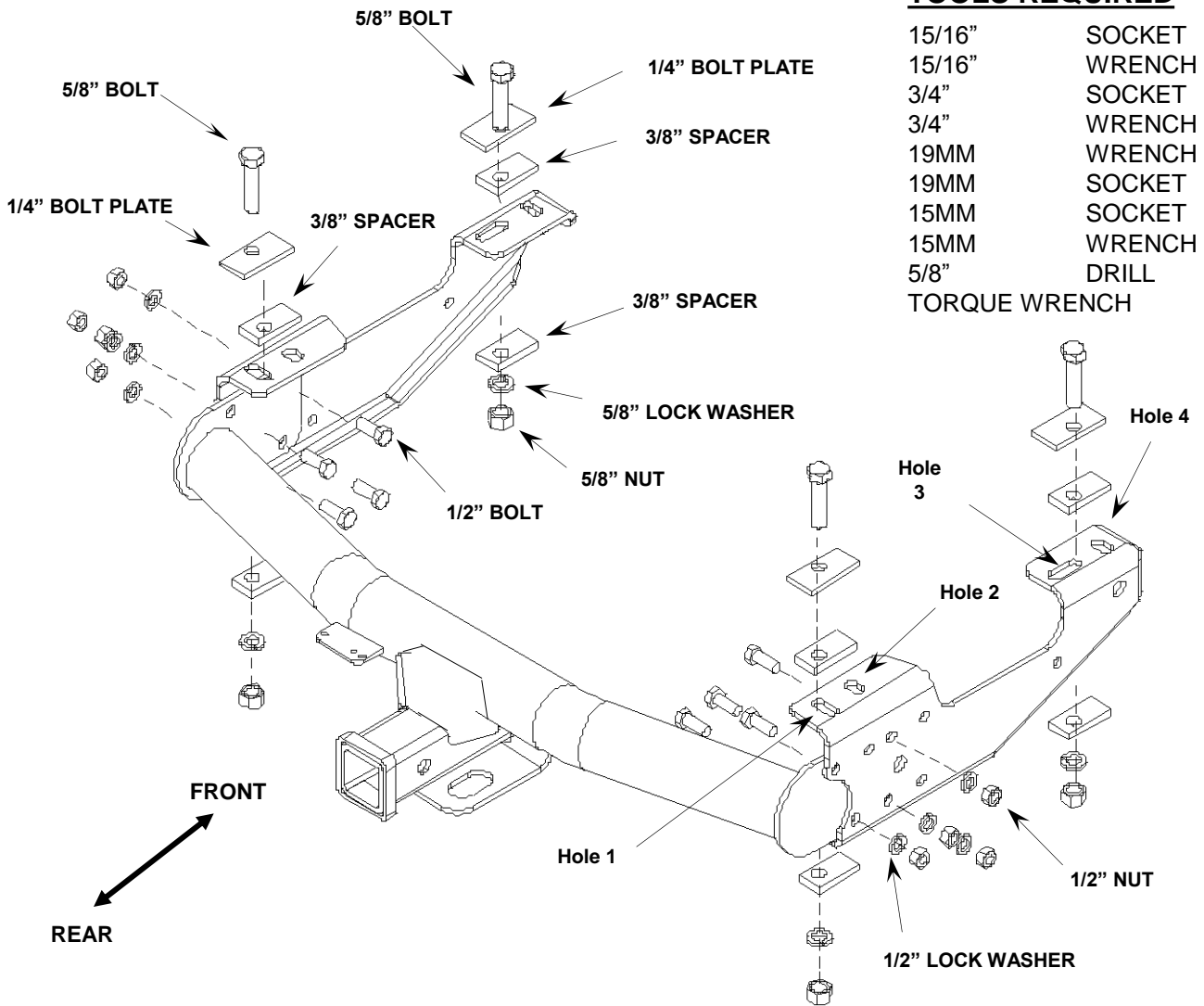

TOOLS REQUIRED

15/16"	SOCKET
15/16"	WRENCH
3/4"	SOCKET
3/4"	WRENCH
19MM	WRENCH
19MM	SOCKET
15MM	SOCKET
15MM	WRENCH
5/8"	DRILL
	TORQUE WRENCH

1988-2000 CHEVY & GMC (CLASSIC):

- The 12mm diameter bolts and weld nuts at the end of the frame must be removed. (Wear Eye Protection)** Method 1) Back out the 12mm diameter bolt halfway. Drive the bolt upward by striking the bolt head with a ball peen hammer to break the nut loose. Ream out the bolt hole to 5/8" diameter. Method 2) Remove the 12mm bolt and discard. Using a 5/8" drill bit, drill out the nut. Then remove the remainder with a hammer and chisel. Some vehicles have an additional 8mm diameter bolt on the passenger's side. Remove the bolt and reinstall it with the head on the bottom of the frame.
- If your vehicle has rivets on the bottom of the frame or the 8mm bolt, you will need to install one 3/8" thick spacer between the frame and the bracket at each bolting location. These are needed for clearance between the bracket and the rivet head or 8mm bolt. The bracket can not be bolted directly against the rivets or 8mm bolt.
- Using the supplied hardware, insert 5/8" diameter bolt with bolt plate down through the hole created from the removal of the 12mm nut. Fasten the bracket to the frame. See the illustration. For short bed use hole 2. On long bed use hole 1. **NOTE: SOME DUAL PIPE EXHAUST SYSTEMS WILL HIT THE BRACKET. THE EXHAUST WILL NEED TO BE MODIFIED.** Attach with 3/8" spacer, 5/8" lock washer, and 5/8" nut.
- (Short Beds): Insert 5/8" bolts with bolt plates down through the 1" diameter holes in the frame and into holes (4) in the brackets. Install a 3/8" thick spacer, 5/8" lock washer, and nut on each bolt. Leave the nuts loose at this time.
- (Long Beds): Insert 5/8" bolts with bolt plates down through the 1" diameter holes in the frame and into holes (3) in the brackets. If the forward holes are only 1/2" diameter, use the 5/8" drill bit to enlarge them. Install a 3/8" thick spacer, 5/8" lock washer and nut on each bolt. Leave the nuts loose at this time.
- Place the center section between the brackets as shown. The spare tire may need to be loosened. Bolt through the center section and the bracket with 1/2" bolts, lock washers and nuts. **NOTE:** Be sure to use four holes to bolt the brackets to the center section.
- Tighten the nuts in the following order:
First torque the 1/2" nuts to 70 ft•lb.
Then torque the 5/8" nuts to 115 ft•lb.
- Retighten the spare tire if it was loosened.
- Be sure that the spare tire is not rubbing against the brake hose. If needed, bend the bracket that the hose mounts to a little so that you have clearance between the tire and the brake hose.

TOOLS REQUIRED

15/16"	SOCKET
15/16"	WRENCH
3/4"	SOCKET
3/4"	WRENCH
21MM	SOCKET
	TORQUE WRENCH

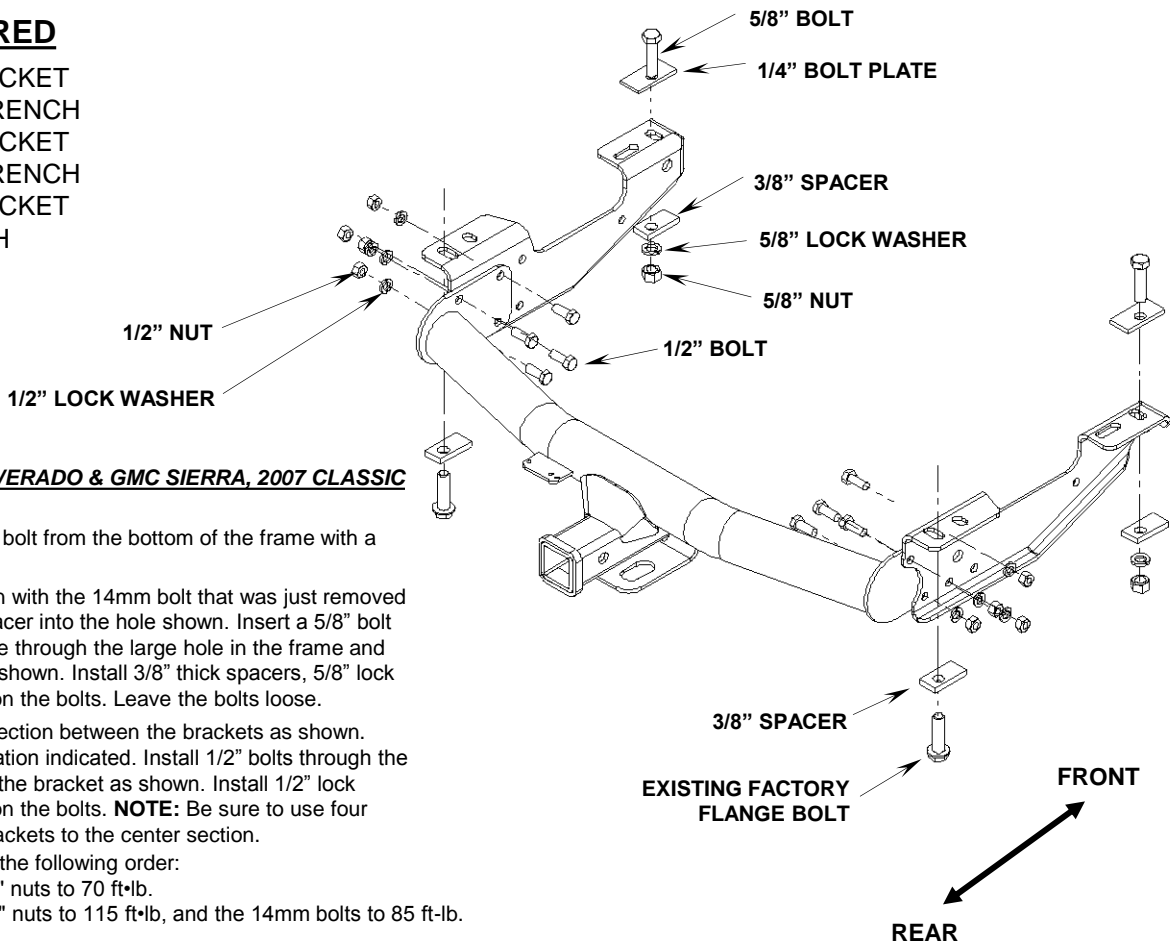

1999-2006 CHEVY SILVERADO & GMC SIERRA, 2007 CLASSIC (LONG BEDS):

1. Remove the 14mm bolt from the bottom of the frame with a 21mm socket.
2. Bolt the brackets on with the 14mm bolt that was just removed and a 3/8" thick spacer into the hole shown. Insert a 5/8" bolt with a 1/4" bolt plate through the large hole in the frame and into the bracket as shown. Install 3/8" thick spacers, 5/8" lock washers and nuts on the bolts. Leave the bolts loose.
3. Install the center section between the brackets as shown. Use the bolting location indicated. Install 1/2" bolts through the center section and the bracket as shown. Install 1/2" lock washers and nuts on the bolts. **NOTE:** Be sure to use four holes to bolt the brackets to the center section.
4. Tighten the nuts in the following order:
First torque the 1/2" nuts to 70 ft•lb.
Then torque the 5/8" nuts to 115 ft•lb, and the 14mm bolts to 85 ft•lb.

TOOLS REQUIRED

15/16"	SOCKET
15/16"	WRENCH
3/4"	SOCKET
3/4"	WRENCH
21MM	SOCKET
	TORQUE WRENCH

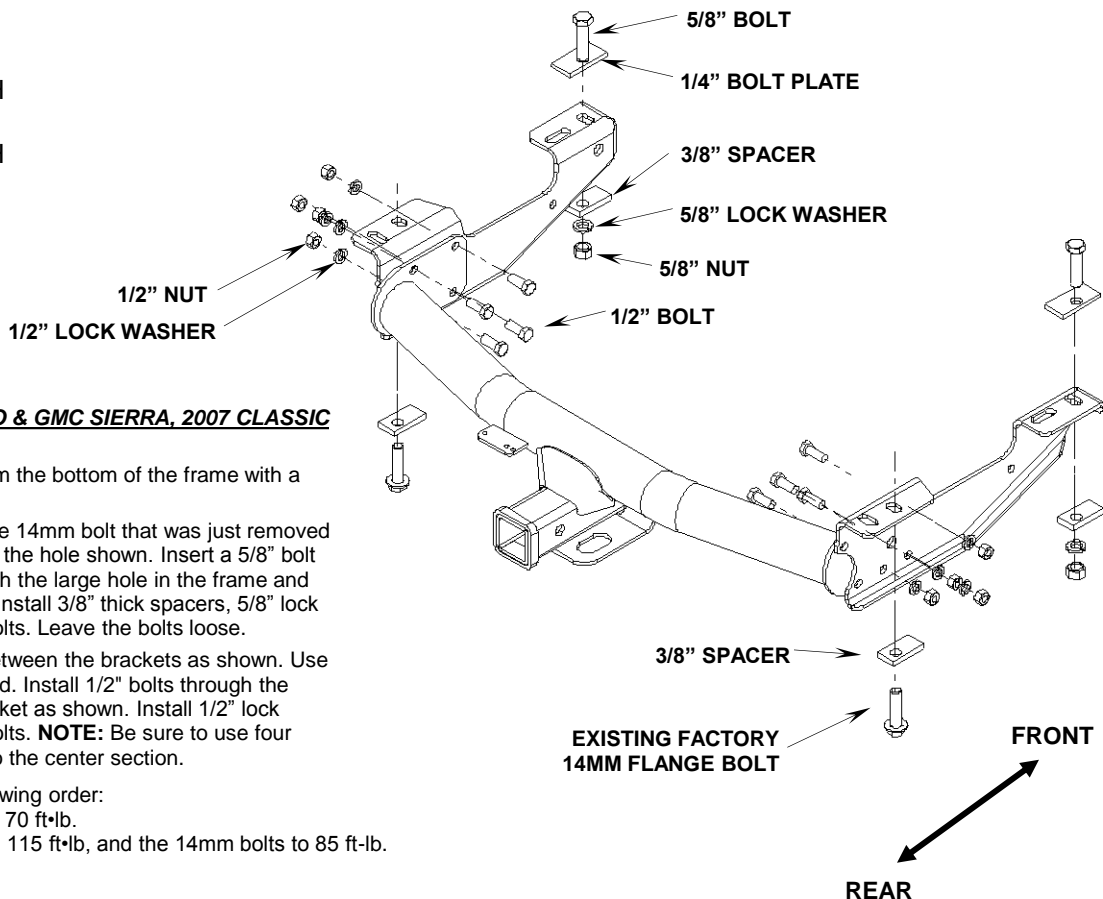

1999-2005 CHEVY SILVERADO & GMC SIERRA, 2007 CLASSIC (SHORT BEDS):

1. Remove the 14mm bolt from the bottom of the frame with a 21mm socket.
2. Bolt the brackets on with the 14mm bolt that was just removed and a 3/8" thick spacer into the hole shown. Insert a 5/8" bolt with a 1/4" bolt plate through the large hole in the frame and into the bracket as shown. Install 3/8" thick spacers, 5/8" lock washers and nuts on the bolts. Leave the bolts loose.
3. Install the center section between the brackets as shown. Use the bolting location indicated. Install 1/2" bolts through the center section and the bracket as shown. Install 1/2" lock washers and nuts on the bolts. **NOTE:** Be sure to use four holes to bolt the brackets to the center section.
4. Tighten the nuts in the following order:
First torque the 1/2" nuts to 70 ft•lb.
Then torque the 5/8" nuts to 115 ft•lb, and the 14mm bolts to 85 ft•lb.

TOOLS REQUIRED

15/16"	SOCKET
15/16"	WRENCH
3/4"	SOCKET
3/4"	WRENCH
21MM	SOCKET
TORQUE WRENCH	
SAFETY GLASSES	

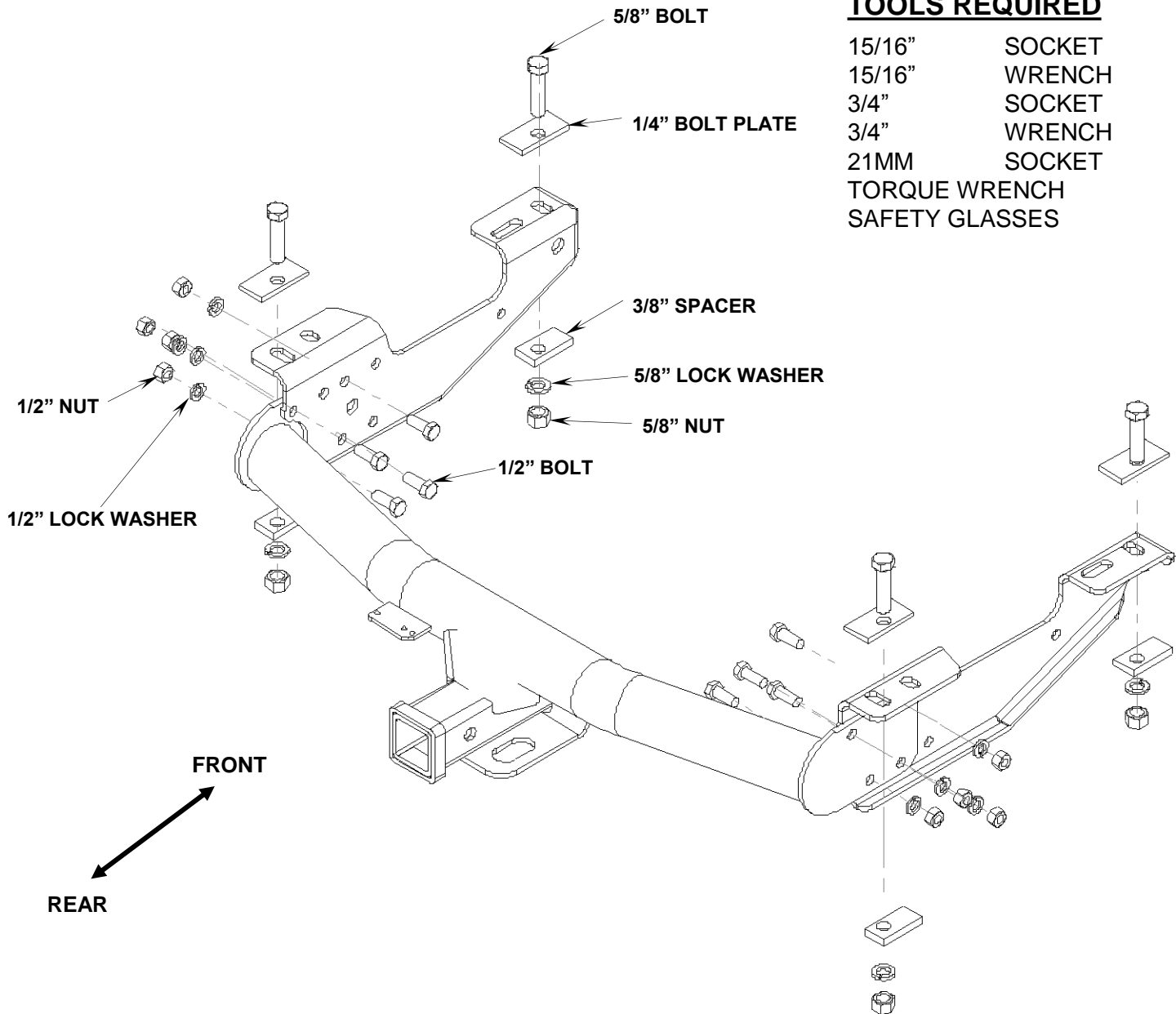

2000-2006 TOYOTA TUNDRA :

1. Ream existing hole at the rear of the frame to accept a 5/8" bolt and install the 5/8" bolts through the bolt plates and into the frame. With the 3/8" spacer, 5/8" lock washer, and 5/8" nut bolt the brackets to the frame. Leave the bolts loose enough to center bracket on frame of truck. Do not install fasteners in the forward hole in the brackets at this time.
2. Install the center section to the brackets as shown. Use the bolting location indicated. Install 1/2" bolts through the center section and the bracket as shown. Install 1/2" lock washers and nuts on the bolts.
3. Using the forward most holes in the brackets as a guide drill a 5/8" hole and install the 5/8" bolts with 1/4" bolt plates through the frame and brackets. Then install the 3/8" spacer, 5/8" lock washer, and 5/8" nuts.

NOTE: Be sure to use four holes to bolt the brackets to the center section.

4. Tighten the nuts in the following order:
First torque the 1/2" nuts to 70 ft•lb.
Then torque the 5/8" nuts to 115 ft•lb.

NOTE: SIDE BRACKETS MAY DEFLECT WHEN TIGHTENED

TOOLS REQUIRED

15/16"	SOCKET
15/16"	WRENCH
3/4"	SOCKET
3/4"	WRENCH
5/8"	DRILL BIT
	TORQUE WRENCH

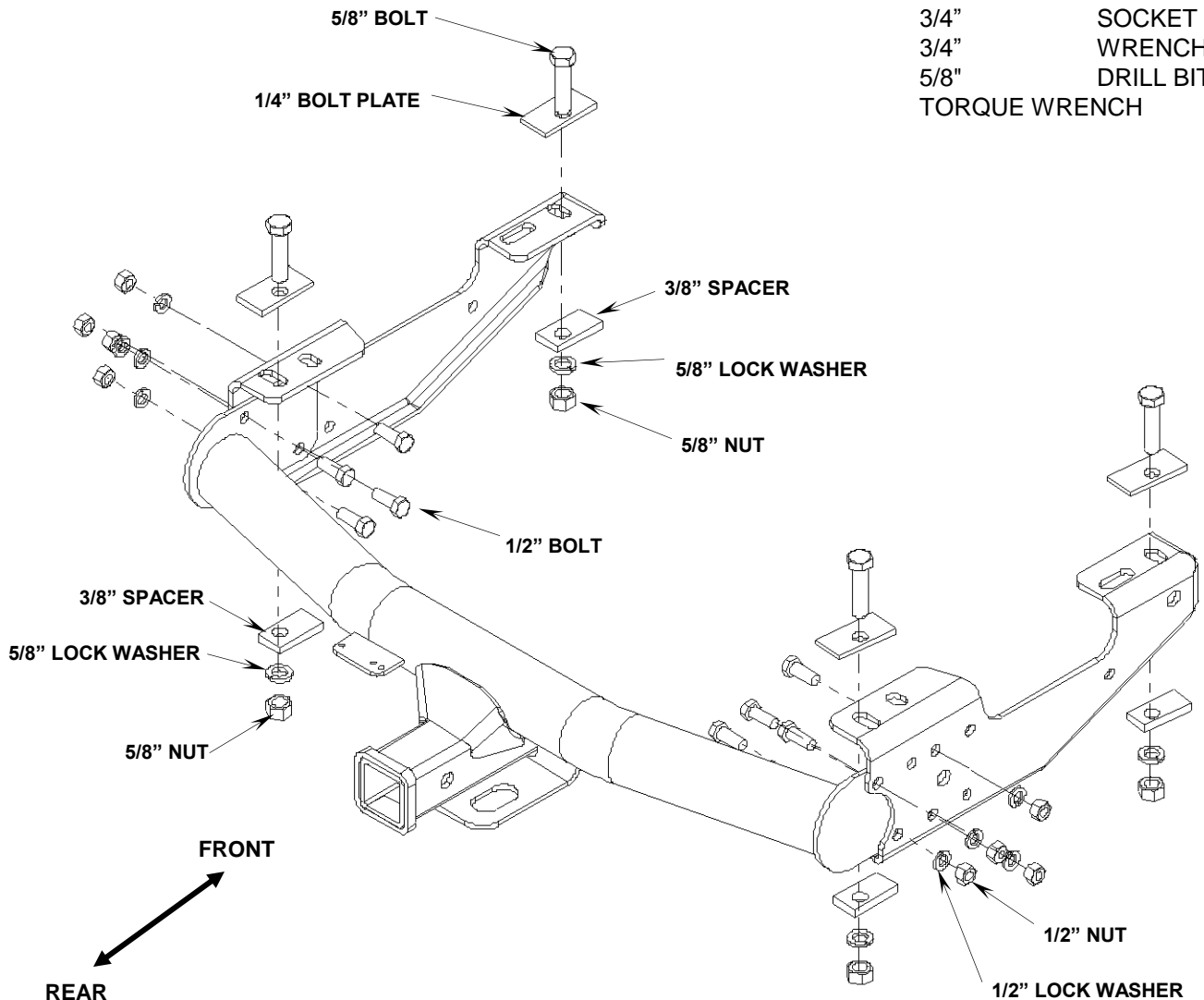

1971-1993 Dodge Pick Up:

1. Insert a 5/8" bolt with a 1/4" bolt plate down through the 1" diameter hole at the end of the frame. Do this on both sides. Fasten the frame brackets as shown, to the frame with 3/8" thick spacers, lock washers and nuts. Leave the bolts loose enough to center bracket on frame of truck.
2. Install the center section between the brackets as shown. Bolt through the center section and the brackets with 1/2" bolts, lock washers and nuts. Use the holes shown. Leave the nuts finger tight at this time. Some spare tire carriers may need to be modified if the hitch hits the carrier. **NOTE:** Be sure to use four holes to bolt the brackets to the center section.
3. Using the hole in the bracket as a guide, drill a 5/8" diameter hole through the frame. Use the farthest front hole. Do this on both sides.
4. Insert 5/8" bolts with 1/4" bolt plates down through the frame and the bracket. Install 3/8" thick spacers, 5/8" lock washers and nuts on the bolts.
5. Tighten the nuts in the following order:
First torque the 1/2" nuts to 70 ft•lb.
Then torque the 5/8" nuts to 115 ft•lb.

NOTE: SIDE BRACKETS WILL DEFLECT WHEN TIGHTENED

TOOLS REQUIRED

5/8"	DRILL BIT
3/8"	DRILL BIT
15/16"	SOCKET
15/16"	WRENCH
3/4"	SOCKET
3/4"	WRENCH
13MM	SOCKET
9/16"	SOCKET
9/16"	WRENCH
	TORQUE WRENCH

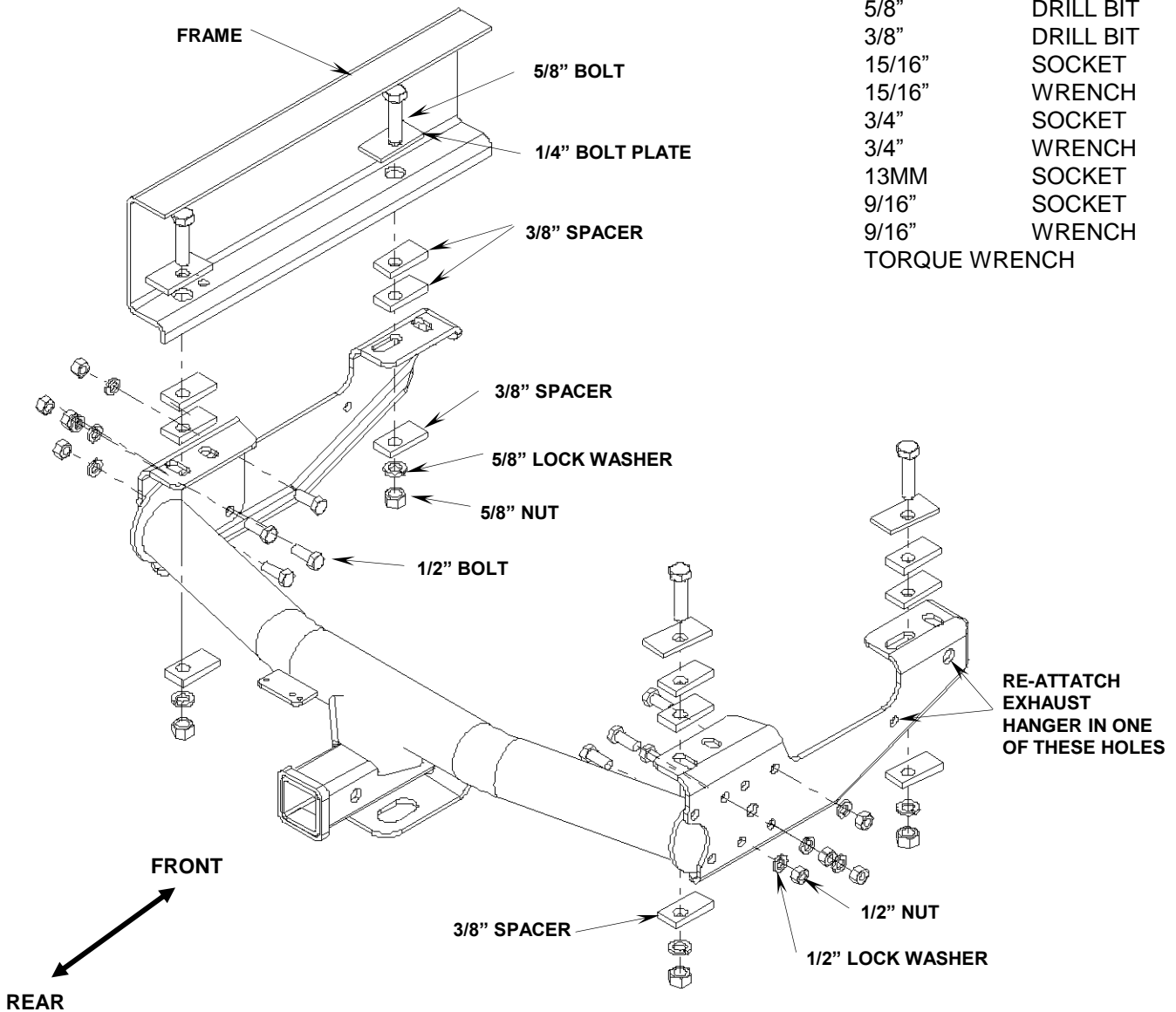

All 1994-2001 and 2002 2500/3500 Dodge Pick Up Short Bed:

1. The spare tire may need to be loosened for installation.
2. Bolt the brackets to the frame as shown with a 5/8" bolt and 1/4" bolt plate inserted through the 1" diameter hole in the end of the frame. Install two 3/8" thick spacers between the frame and brackets at the rear bolting locations. Install 3/8" thick spacers, lock washers and nuts on the bolts. **NOTE:** For some models, the exhaust hanger will need to be unbolted from the frame.
3. Install the center section between the brackets as shown. Use the hole pattern that works best for your truck. Insert 1/2" bolts through the center section and the brackets. Install 1/2" lock washers and nuts on the bolts. Finger tighten the bolts at this time. **NOTE:** Be sure to use four holes to bolt each bracket to the center section.
4. Using the hole in the bracket as a guide, drill a 5/8" hole through the frame. Use the hole shown in the diagram. Install 5/8" bolts with bolt plates into the holes. Be sure to insert two 3/8" thick spacers between the frame and the brackets. Install 3/8" thick spacers, lock washers and nuts on the bolts.
5. If the exhaust hanger was removed, drill a 3/8" hole through the hanger and attach it to the hitch bracket in one of the holes indicated. Use the 3/8" hardware provided to re-attach the exhaust hanger.
6. Tighten the nuts in the following order:
First torque the 1/2" nuts to 70 ft•lb.
Then torque the 5/8" nuts to 115 ft•lb.
7. If the spare tire was loosened, retighten it now.

TOOLS REQUIRED

3/8"	DRILL BIT
15/16"	SOCKET
15/16"	WRENCH
3/4"	SOCKET
3/4"	WRENCH
13MM	SOCKET
9/16"	SOCKET
9/16"	WRENCH
	TORQUE WRENCH

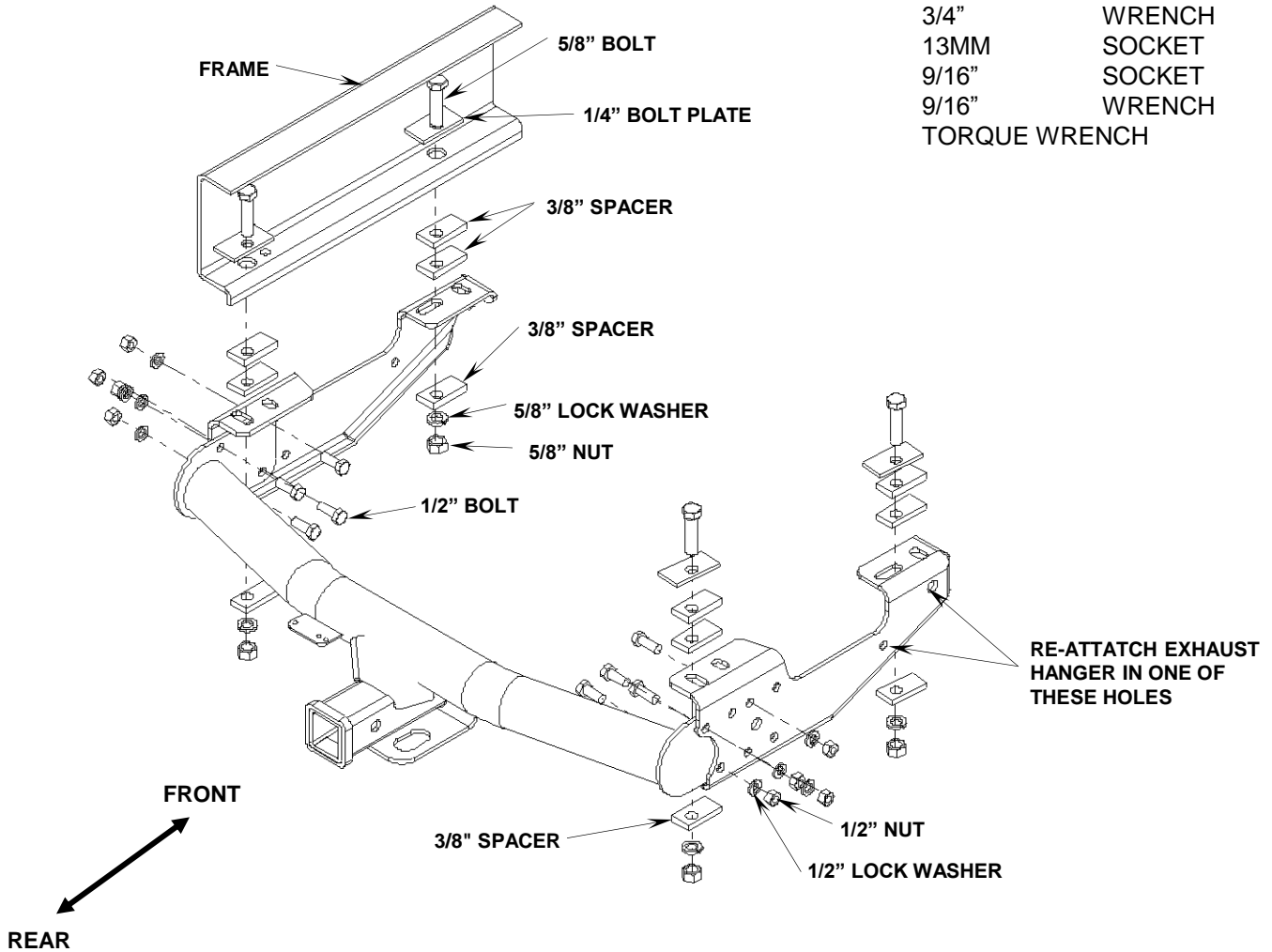

All 1994-2001 and 2002 2500/3500 Dodge Pick Up Long Bed:

1. The spare tire may need to be loosened for installation.
2. Bolt the brackets to the frame as shown with a 5/8" bolt and 1/4" bolt plate inserted through the 1" diameter hole in the end of the frame. Install two 3/8" thick spacers between the frame and brackets at the rear bolting locations. Install 3/8" thick spacers, lock washers and nuts on the bolts. **NOTE:** For some models, the exhaust hanger will need to be unbolted from the frame.
3. Install the center section between the brackets as shown. Use the hole pattern that works best for your truck. Insert 1/2" bolts through the center section and the brackets. Install 1/2" lock washers and nuts on the bolts. Finger tighten the bolts at this time. **NOTE:** Be sure to use four holes to bolt each bracket to the center section.
4. Insert a 5/8" bolt with a 1/4" bolt plate through the 1" hole in the frame and into the bracket as shown. Insert two 3/8" thick spacers between the frame and the bracket. Install a 3/8" thick spacer, 5/8" lock washer and nut on the bolt. Do this on both sides.
5. If the exhaust hanger was removed, drill a 3/8" hole through the hanger and attach it to the hitch bracket in one of the holes indicated. Use the 3/8" hardware provided to re-attach the exhaust hanger.
6. Tighten the nuts in the following order:
First torque the 1/2" nuts to 70 ft•lb.
Then torque the 5/8" nuts to 115 ft•lb.
7. If the spare tire was loosened, retighten it now.