

# INSTALLATION INSTRUCTIONS

## FORD F-350, F-450, & F-550

### With 34" Frame

Product No.  
**37088**

SMALL PARTS  
PACKAGE F37088



**WARNING:** DO NOT LUBRICATE THREADS, BOLT FAILURE MAY OCCUR DUE TO OVER TIGHTENING.  
**WARNING:** DO NOT DRILL OR WELD TO THIS HITCH.

**IMPORTANT NOTES**  
USE ONLY TOWING PRODUCTS SUPPLIED OR APPROVED BOLTS, LOCKNUTS, AND WASHERS TO INSTALL THIS HITCH

### TOOLS REQUIRED

3/4"	SOCKET
15/16"	SOCKET
15/16"	WRENCH
5/8"	DRILL
2-	CLAMPS
	TORQUE WRENCH

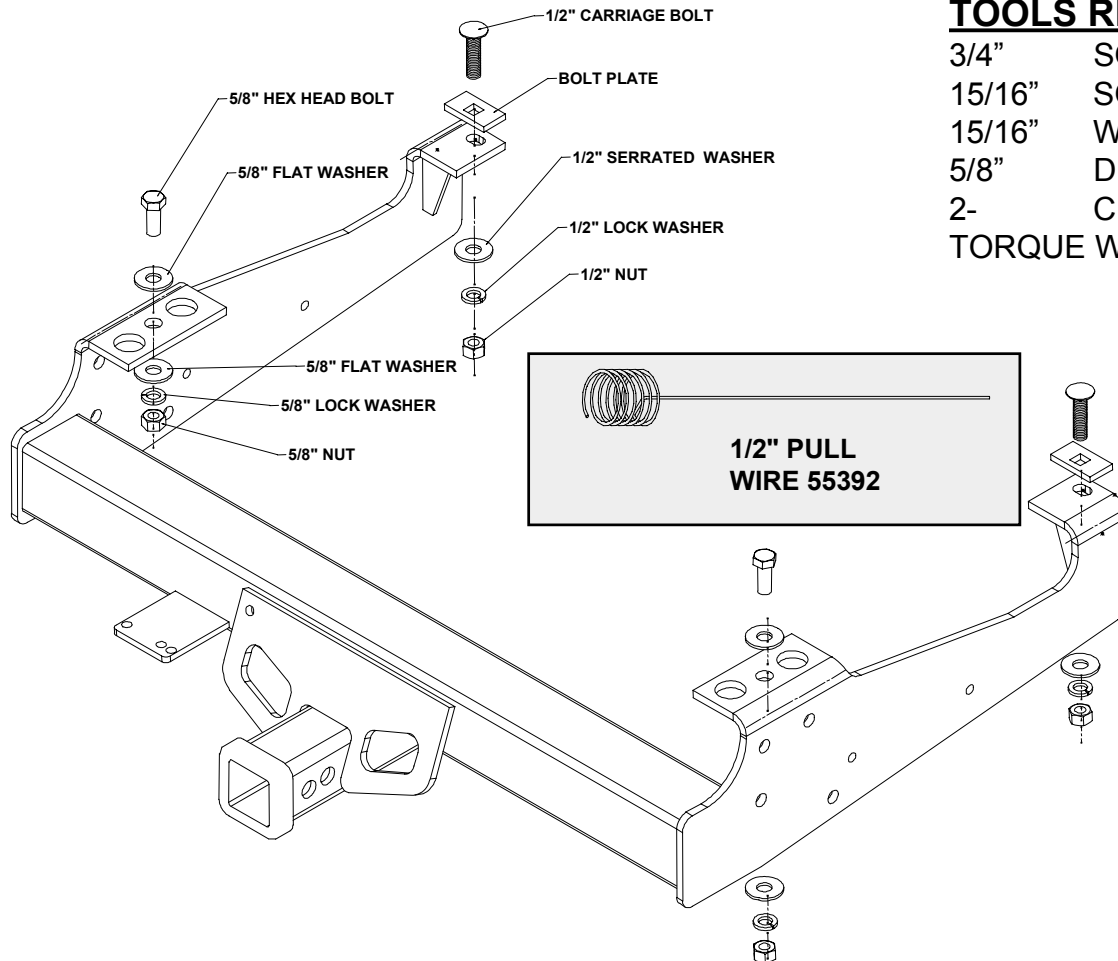

1. Hold the hitch up under the frame. Position the holes in the brackets over the rivet heads at the rear of the frame. Clamp the hitch in place.
2. Install 1/2" carriage bolts with bolt plates down through the holes in the frame beside the spring hangers. Install 1/2" serrated washers, 1/2" lock washers, and 1/2" nuts on the bolts. See diagram above. It may be necessary to screw the 1/2" carriage bolt with bolt plate onto the pull wire. Some gas tanks will limit access to the hole inside the frame. Use the pull wire to pull the bolt into the hole in the frame. Feed the wire through from a more open area in the frame.
3. Using the rear holes in the bracket as a guide, drill a 5/8" hole into the bottom of the frame. Install the 5/8" bolts with 5/8" flat washers down through the frame and through the brackets. Install 5/8" flat washers, 5/8" lock washers, and 5/8" nuts on the bolts. See diagram above.
4. Torque 5/8" nuts to 115 ft\*lbs.  
Torque 1/2" nuts to 70 ft\*lbs.

(OVER)

**INSTALLATIONS FOR:  
FONTAINE CONVERSIONS**

**TOOLS REQUIRED**

- 3/4" SOCKET
- 3/4" WRENCH
- TORQUE WRENCH

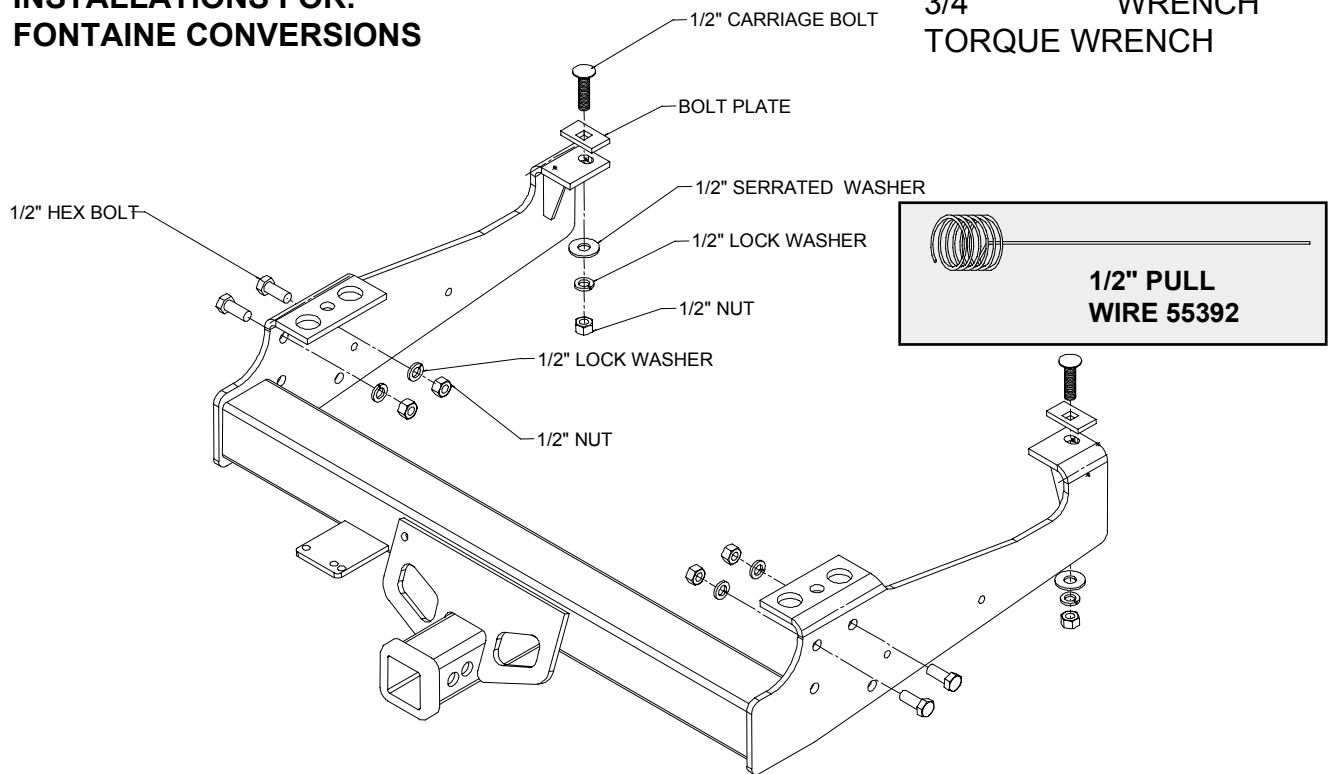

1. Hold the hitch up under the frame. Position the holes in the brackets over the rivet heads at the rear of the frame.
2. Insert 1/2" hex head bolts into the plate that extends down from the frame. Install 1/2" lock washers, and 1/2" nuts on all four bolts. See diagram above. It may be necessary to screw the 1/2" carriage bolt with bolt plate onto the pull wire. Some gas tanks will limit access to the hole inside the frame. Use the pull wire to pull the bolt into the hole in the frame. Feed the wire through a more open area in the frame.
2. Install 1/2" carriage bolts with bolt plates down through the holes in the frame beside the spring hangers. Install 1/2" serrated washers, 1/2" lock washers, and 1/2" nuts on the bolts. See diagram above.
4. Torque 1/2" nuts to 70 ft\*lbs.

THIS PRODUCT COMPLIES WITH SAFETY SPECIFICATION AND REQUIREMENTS FOR THE STATE OF NEW YORK AND VESC REGULATION V-5 FOR CONNECTING DEVICES AND TOWING SYSTEMS. WEIGHT DISTRIBUTING HITCH RATING IS 12000 LB. MAX. GROSS TRAILER WEIGHT AND 1200 LB. MAX. TONGUE WEIGHT. WEIGHT CARRYING HITCH RATING IS 7500 LB MAX GROSS TRAILER WEIGHT AND 750 LB MAX TONGUE WEIGHT. CONSULT VEHICLE OWNERS MANUAL FOR TOWING RECOMMENDATIONS AND LIMITATIONS.