

REESE

INSTALLATION INSTRUCTIONS

Product No.

FORD EXPLORER

37012

You *can* take it with you.

SMALL PARTS
PACKAGE 37340

WARNING: DO NOT LUBRICATE THREADS, BOLT FAILURE MAY OCCUR DUE TO OVER TIGHTENING.
WARNING: DO NOT DRILL OR WELD TO THIS HITCH.

IMPORTANT NOTES
USE ONLY REESE SUPPLIED OR APPROVED BOLTS, LOCKNUTS, AND WASHERS TO INSTALL THIS HITCH

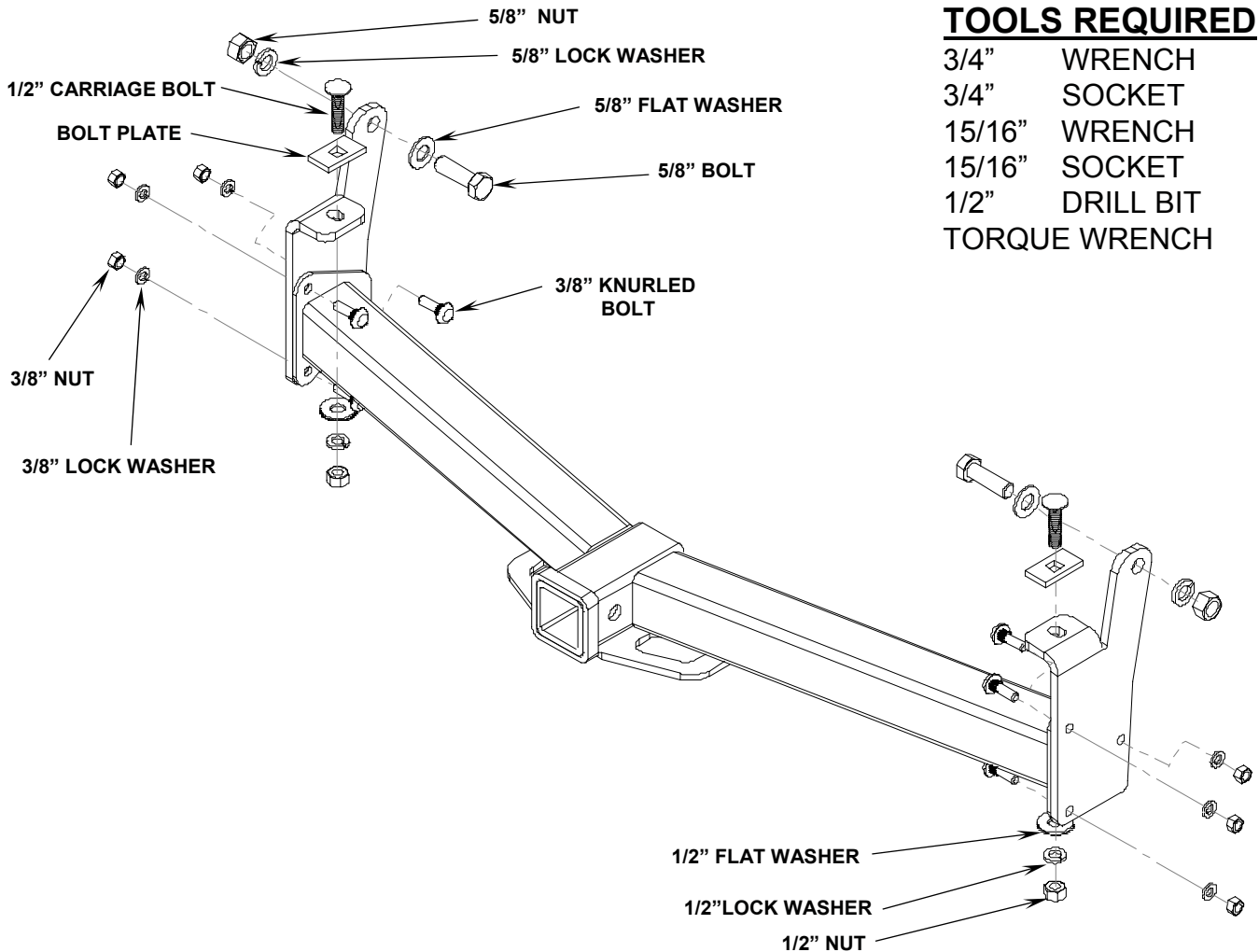

PRE-1997

1. Mount side brackets to the frame using the 5/8" bolt, 5/8" flat washer, 5/8" lock washer, and 5/8" nut. Leave nut loose. Mount center section between the side brackets using the 3/8" knurled bolts, 3/8" lock washers, and 3/8" nuts. Hand tighten all of the nuts.
2. Using the 1/2" hole in the flange mark the frame and drill a 1/2" hole in the frame. Install 1/2" carriage bolt, bolt plate, 1/2" flat washer, 1/2" lockwasher, and 1/2" nut on both sides.
3. Torque 5/8" nuts to 100 lb*ft.
Torque 1/2" nuts to 70 lb*ft.
Torque 3/8" nuts to 35 lb*ft.

(OVER)

1997-CURRENT

NOTE: Sport versions will need to remove the tow hook to install the hitch.

- 1. Mount side brackets to the frame using the 5/8" bolt, 5/8" flat washer, and 5/8" lock washer, and 5/8" nut. Install 1/2" carriage bolt, bolt plate, 1/2" flat washer, 1/2" lockwasher, and 1/2" nut on both sides. Leave nut loose.**
- 2. Mount center section between the side brackets using the 3/8" knurled bolts, 3/8" lock washers, and 3/8" nuts.**
- 3. Torque 5/8" nuts to 100 lb*ft.
Torque 1/2" nuts to 70 lb*ft.
Torque 3/8" nuts to 35 lb*ft.**

THIS PRODUCT COMPLIES WITH SAFETY SPECIFICATION AND REQUIREMENTS FOR THE STATE OF NEW YORK AND VESC REGULATION V-5 FOR CONNECTING DEVICES AND TOWING SYSTEMS. WEIGHT DISTRIBUTING HITCH RATING IS 6000 LB. MAX. GROSS TRAILER WEIGHT AND 600 LB. MAX. TONGUE WEIGHT. WEIGHT CARRYING HITCH RATING IS 5000 LB MAX GROSS TRAILER WEIGHT AND 500 LB MAX TONGUE WEIGHT. CONSULT VEHICLE OWNERS MANUAL FOR TOWING RECOMMENDATIONS AND LIMITATIONS.