

INSTALLATION INSTRUCTIONS

EQUIPMENT REQUIRED: TAPE
 WIRING ACCESS LOCATION: SUV7
 DRILL BITS: NONE
 HITCH REQUIRES 5/8" PIN AND CLIP IF STABILIZING PIN IS NOT INSTALLED.
 WRENCHES: (TIGHTEN ALL FASTENERS WITH TORQUE WRENCH) 17mm, 18mm

VEHICLE	HITCH NO.
TOYOTA LANDCRUISER	41015
LEXUS LX450	33066
	87549

DO NOT EXCEED LOWER OF
 TOWING VEHICLE MFR'S RATINGS OR

HITCH TYPE ▼	MAX GROSS TRLR WT(LB)	MAX TONGUE WT(LB)
WEIGHT DISTRIBUTING	6000	750
WEIGHT CARRYING BALL MOUNT	5000	500

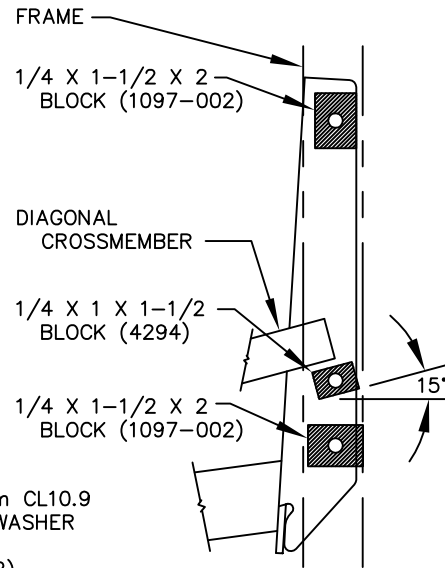
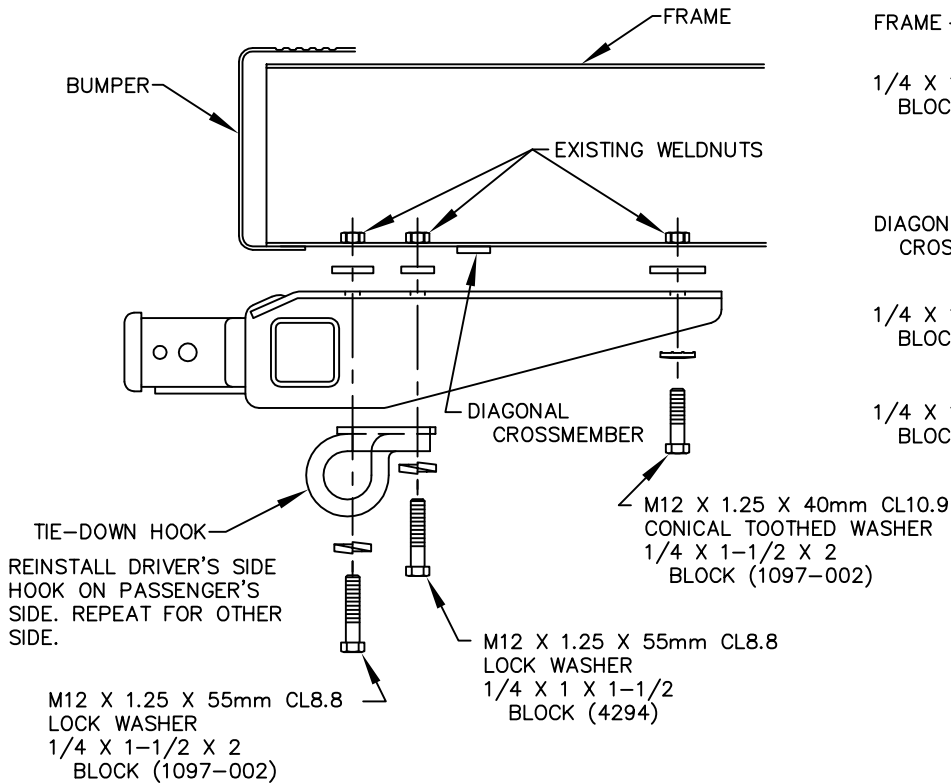
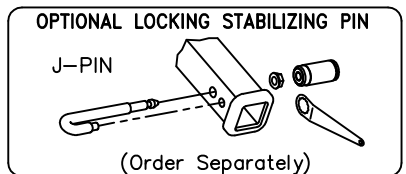

FIGURE 1
 TYPICAL BOTH SIDES

NOTE: PROPER ORIENTATION OF BLOCKS IS NECESSARY TO INSURE HITCH SITS FLAT.



1. REMOVE TIE-DOWN HOOK (TWO BOLTS PER SIDE) LOCATED AT THE END OF EACH FRAME. MARK THE TIE-DOWN HOOKS FOR REINSTALLATION LATER. RETURN FASTENERS TO VEHICLE OWNER.
2. RAISE HITCH INTO POSITION, PLACING AND ORIENTING BLOCKS BETWEEN FRAME AND HITCH AS SHOWN IN FIGURE 1. TAPING THE BLOCKS TO THE HITCH MAY BE HELPFUL. IT IS IMPORTANT THAT BLOCKS SIT FLAT AGAINST THE FRAME.
3. INSTALL M12 X 1.25 X 55mm CL8.8 HEX BOLT THROUGH LOCK WASHER, TIE-DOWN HOOK, HITCH AND BLOCK INTO EXISTING WELDNUIT INSIDE THE FRAME (2 BOLTS PER SIDE) AS SHOWN ABOVE.
4. INSTALL FORWARD ATTACHMENT FASTENERS AS SHOWN.

NOTES: TIE-DOWN HOOKS ARE REINSTALLED ON THE OPPOSITE FRAME RAIL FROM WHICH THEY WERE REMOVED IN STEP 1.

TIGHTEN M12 X 1.25 CL10.9 FASTENERS TO 92 LB.-FT.
 TIGHTEN M12 X 1.25 CL8.8 FASTENERS TO 68 LB.-FT.

THIS PRODUCT COMPLIES WITH SAFETY SPECIFICATIONS AND REQUIREMENTS FOR CONNECTING DEVICES AND TOWING SYSTEMS OF THE STATE OF NEW YORK AND V.E.S.C. REGULATION V-5.

APPROX WEIGHT (LB.)	FASTENER KIT
39.1	1130-751

NOTE: Check hitch frequently, making sure all fasteners and ball are properly tightened. If hitch is removed, plug all holes in trunk pan or other body panels to prevent entry of water and exhaust fumes. A hitch or ball which has been damaged should be removed and replaced. Observe safety precautions when working beneath a vehicle and wear eye protection. Follow car maker's specs for maximum trailer weight and tongue weight. Do not cut access or attachment holes with a torch.

TOWING PRODUCTS