

Installation Instructions

Part Numbers:

Volvo V70
Volvo S60

36297
06420

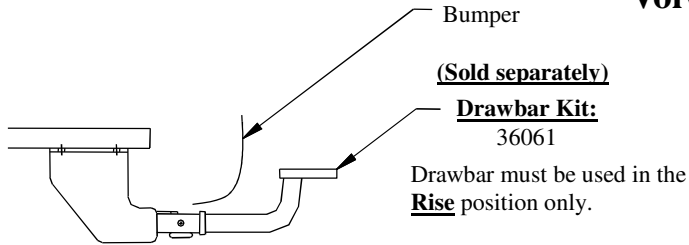

**Do Not Exceed Lower of Towing Vehicle
Manufacturer's Rating or**

3500 LB, (1589 Kg) Max Gross Trailer Weight

300 LB, (136 Kg) Max Tongue Weight

Wiring Access Location: PC3, PC4

Hitch Shown In Proper Position

Equipment Required:

Fastener Kit: Uses Existing Fasteners

Wrenches: 17mm

Drill Bits: None

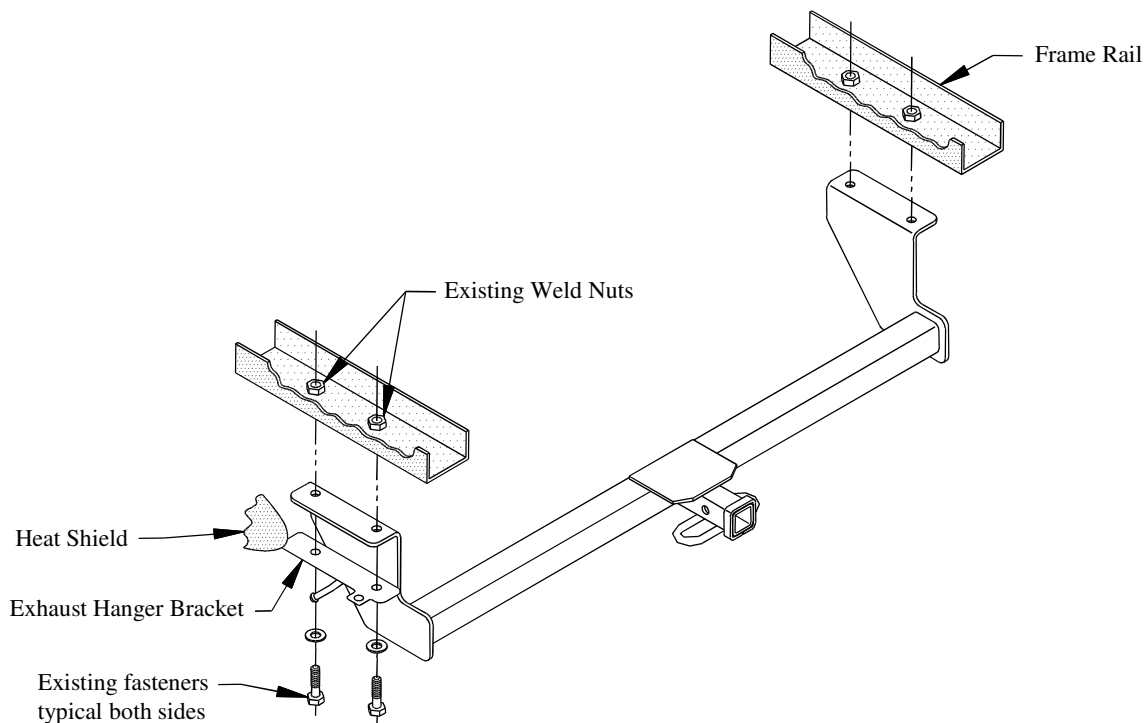

1. Remove tie-down bracket from passenger side frame rail.
2. Remove two (2) exhaust hanger bracket bolts from driver side frame rail.
3. Lower exhaust hanger bracket and heat shield.
4. Raise hitch into position and install between frame and exhaust hanger bracket using existing fasteners as shown above.
5. Return tie-down bracket to vehicle owner.

Tighten all M12 CL9.8 fasteners with torque wrench to 75 Lb.-Ft. (102 N*M)

Note: check hitch frequently, making sure all fasteners and ball are properly tightened. If hitch is removed, plug all holes in trunk pan or other body panels to prevent entry of water and exhaust fumes. A hitch or ball which has been damaged should be removed and replaced. Observe safety precautions when working beneath a vehicle and wear eye protection. Do not cut access or attachment holes with a torch.

This product complies with safety specifications and requirements for connecting devices and towing systems of the state of New York, V.E.S.C. Regulation V-5 and SAE J684.