

Installation Instructions

SUBARU LEGACY SEDAN AND WAGON

SUBARU OUTBACK SEDAN AND WAGON

(EXCLUDING SPORT)

Part Numbers:

36334

06377

90138

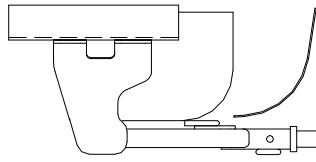
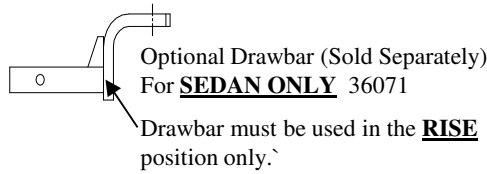

Hitch Shown In Proper Position

(Sold separately)
Drawbar Kit:
36053

Drawbar must be used in the **RISE** position only.

Do Not Exceed Lower of Towing Vehicle
Manufacturer's Rating or

3500 LB (1589 Kg) Max Gross Trailer Weight

300 LB (136 Kg) Max Tongue Weight

Wiring Access Location: PC1, PC2

Equipment Required:

Fastener Kit: 36334F

Wrenches: 3/4, 14mm, 17mm

Drill Bits: None

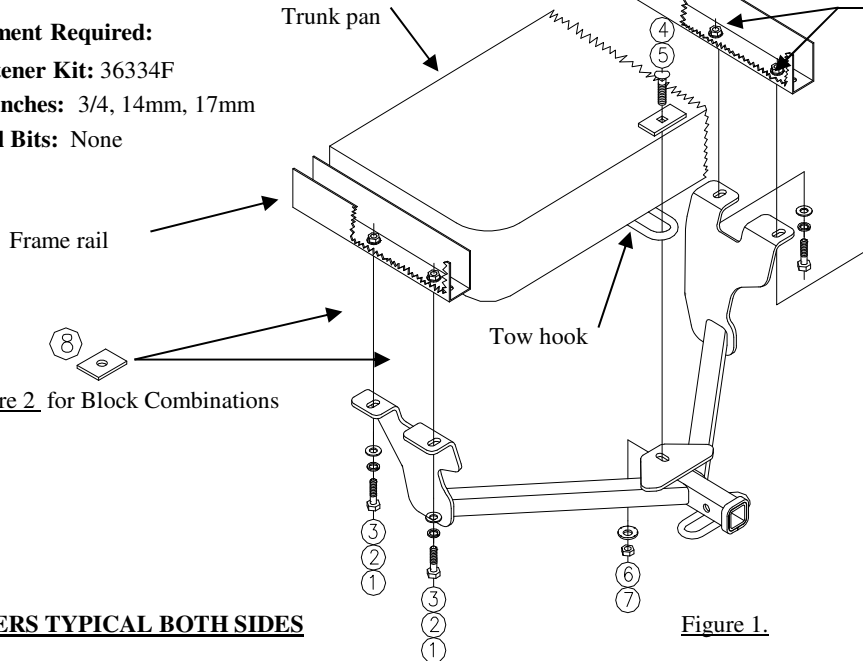

See [Figure 2](#) for Block Combinations

Existing vehicle bracket

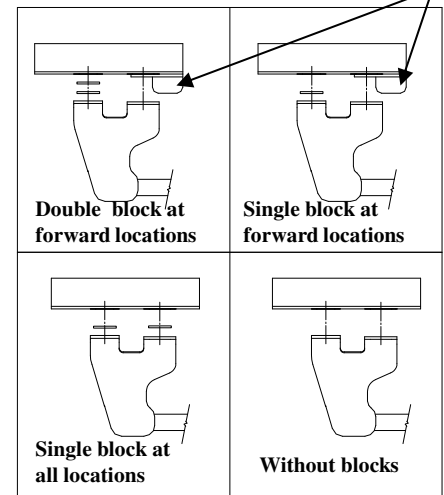

Figure 2.

FASTENERS TYPICAL BOTH SIDES

Figure 1.

①	Qty. (4)	Bolt M10 X 1.25 X 40mm	⑤	Qty. (1)	Block (Large)
②	Qty. (4)	Lock Washer 7/16	⑥	Qty. (1)	Conical Washer 1/2
③	Qty. (4)	Flat Washer 3/8	⑦	Qty. (1)	Hex Nut 1/2-13
④	Qty. (1)	Carriage Bolt 1/2-13 X 1.75	⑧	Qty. (4)	Block (Small)

1. Remove the four muffler hangers (two per side) to allow the exhaust to hang down away from the frame.
2. On the wagon models, remove the forward most bolt (one per side) on the bracket that is bolted to the underside of the frame at the back of the vehicle. Note: on the sedan and wagon you will need to remove the plastic plugs covering the weld nuts in the vehicle frame.
3. **Raise hitch into position and loosely install the tow hook fasteners as shown above.**
4. Block locations vary by vehicle model. Attach with block combination that fills gaps between hitch brackets and vehicle frame. Install fasteners as shown in [Figure 1](#).
5. Tighten 1/2-13 GR5 fasteners to 75 Lb.-Ft. (102 N*M). And tighten M10 CL8.8 fasteners to 38 Lb.-Ft. (52 N*M)
6. Reinstall the four muffler hangers.

Note: check hitch frequently, making sure all fasteners and ball are properly tightened. If hitch is removed, plug all holes in trunk pan or other body panels to prevent entry of water and exhaust fumes. A hitch or ball which has been damaged should be removed and replaced. Observe safety precautions when working beneath a vehicle and wear eye protection. Do not cut access or attachment holes with a torch.

This product complies with safety specifications and requirements for connecting devices and towing systems of the state of New York, V.E.S.C. Regulation V-5 and SAE J684.