

Adjustable Tri-Ball Mount

**Model Number:
7068900**

- Perfect for towing trailers of varying heights and couplers
- Rated up to 14k Gross Towing Weight
- Cast shank
- Integrated step with safe grip pattern
- Black powder coat finish
- Max rise 5-11/16", Max drop 4-3/4"



1-7/8" Ball

2,000 Lbs. GTW

200 Lbs. TW

2" Ball

10,000 Lbs. GTW

1,000 Lbs. TW

2-5/16" Ball

14,000 Lbs. GTW

1,400 Lbs. TW



This Instruction Sheet contains IMPORTANT safety information. Please read and keep for future reference.



CEQUENT™
CONSUMER PRODUCTS

⚠ WARNING

READ and Follow all Instructions and safety messages before installing using the Adjustable Tri-Ball Mount.

Failure to follow these instructions may result in DEATH or SERIOUS INJURY

The attachment of this product is critical and beyond the control of Cequent Consumer Products. Cequent Consumer Products is NOT responsible for its attachment or its installation. It neither guarantees, nor will it be liable for any damage resulting from its attachment, installation or improper use. The liability of this product is limited to its purchase price if it proves to be defective in material and/or workmanship.

- Spindle pin & clip must be re-attached before use
- Use only with couplers marked with the same hitch ball size.
- DO NOT exceed the lower load rating of ball or hitch
- DO NOT fasten safety chain to hitch ball.
- DO NOT attach tow chain, cable, rope, elastic strap, nor elastic rope to hitch ball.
- ALWAYS step on treaded surface of hitch step

This product complies with safety specifications and requirements for the state of New York, VESC regulation V-5, and CSA standard D-264 for connecting devices and towing items.

THIS WARNING IS GIVEN IN COMPLIANCE WITH CALIFORNIA PROPOSITION 65

WARNING: This product contains chemicals known to the state of California to cause cancer, birth defects or other reproductive harm.

NOTICE

Place a small amount of heavy oil or grease on ball before each use.

INSTALLATION INSTRUCTIONS

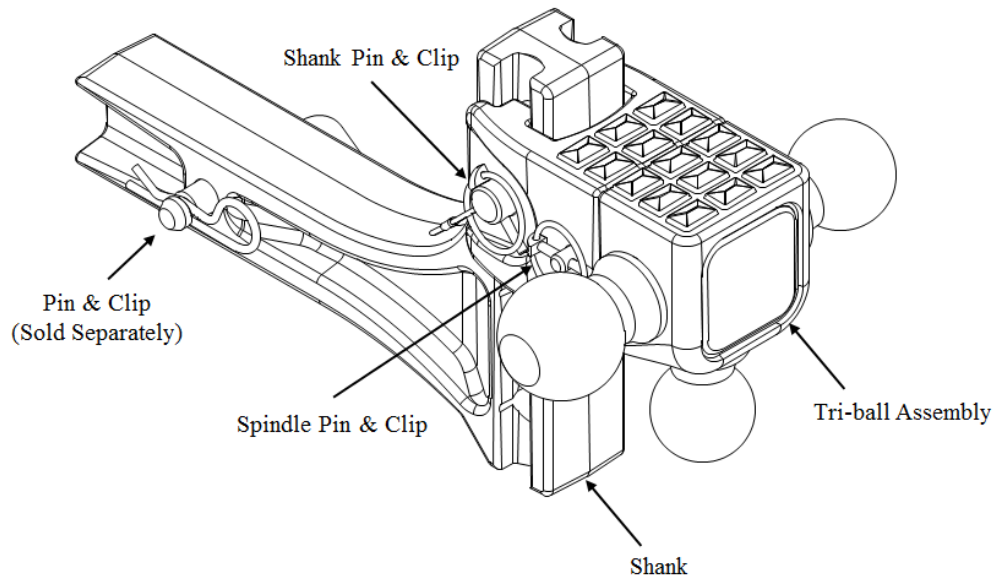

1. Insert shank into hitch receiver and attach pin & clip (sold separately).
2. Insert tri-ball assembly onto the shank, adjust to proper height and attach shank pin & clip. (Height adjustment is in increments of 1.25 inches.)
3. Remove spindle pin & clip, rotate to select ball size or step, and reinstall spindle pin & clip.

Note: See Figure 1 for maximum drop position and Figure 2 for maximum rise position.

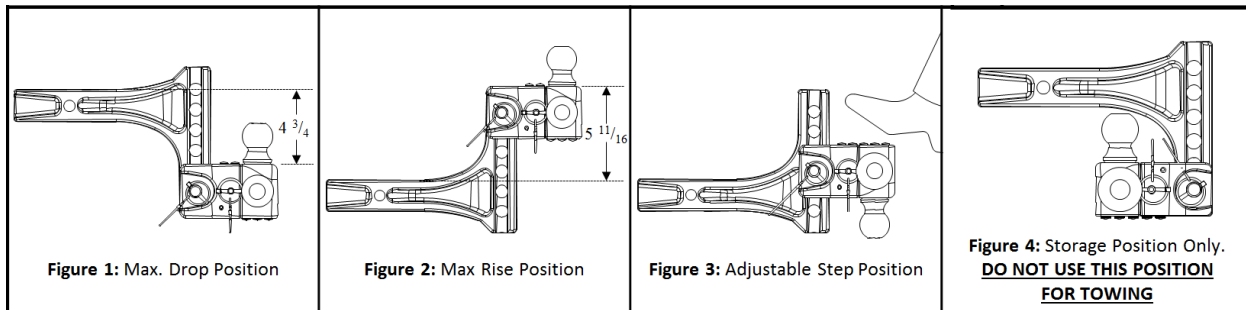

Note: Check for proper ball mount height with vehicle and trailer loaded for travel. At proper adjustment the trailer coupler and tongue should be level with the ground. See Figure 5.

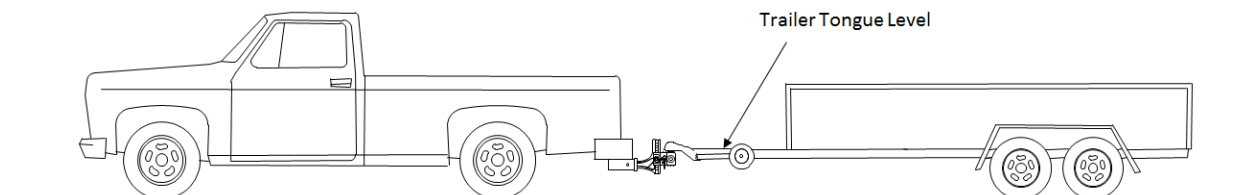

Figure 5: Proper Ball Height

Note: Check hitch frequently, making sure all fasteners are properly tightened. A hitch or ball which has been damaged should be removed and replaced. This product complies with safety specifications and requirements for connecting devices and towing systems of the state of New York, V.E.S.C. Regulation V-5 and SAE J684.

Looking for dependable trailer hitches and towing? Rely on Reese Explore for quality and long-lasting products.