



“Trac-Link” Traction Arm System Mounting Kit

(For Rear Leaf Spring Vehicles Only, Equipped With RCD Rear Suspension Lift Kits)

Installation Instructions

P/N 10-60050

NOTE: Trac-Link Arms Are Individually Packaged And Must Be Ordered Separately.

NOTE: Each Lift Kit, and options to Lift Kits, are packaged separately. Therefore installation procedures are covered in separate instructions. Familiarize yourself with each specific set of instructions before beginning.

<u>Item</u>	<u>Description</u>	<u>Qty.</u>	<u>Illus.</u>
20-71800-4	Trac-Link, Front Mount	2	3
20-71800-5	Trac-Link, Rear Mount Driver	1	1
20-71800-6	Trac-Link, Rear Mount Passenger	1	
20-69670	Hardware Pack Containing:		
13-21183-Z	Hex Bolt, 1/2"- 13 x 5-1/2" Lg.	2	1
13-21404-Z	Hex Bolt, 1/2"- 13 x 4-1/2" Lg.	2	3
13-30034-Z	Flat Washer, 1/2" SAE	8	1, 3
13-10038-Z	Nyloc Nut, 1/2"- 13	4	1, 3
20-830580	Sleeve, 7/8" x 2.812" Lg.	2	2
20-830567	Sleeve, 7/8" x 3.937" Lg.	2	2
15-10953	Red Pivot Bushing	8	2
20-65601	Hardware Pack Containing:		
13-20142-Z	Hex Bolt, 7/16"- 14 x 1-1/4" Lg.	6	3
13-30117-Z	Flat Washer, 7/16"	12	3
13-10133-Z	Nyloc Nut, 7/16"- 14	6	3

BEFORE YOU BEGIN:

Read instructions carefully and study the illustrations before attempting installation. *RCD Suspension* is not responsible for damage, failure or injury resulting from improper installation or parts substitution of this kit.

Check the parts and hardware against the parts list to assure that your kit is complete. Report any shortages to *RCD Suspension*. The parts and hardware supplied are of high-grade material and must not be replaced by inferior parts or failure may result.

Separate parts according to the areas they will be used. Placing the hardware with brackets before you begin will save installation time.

This kit is supplied as a bolt-on assembly. Do not weld anything to the components and do not weld the components to the vehicle.

All components in this kit come with a protective coating. Do not plate (i.e. chrome, cadmium, zinc etc.) or otherwise alter the finish in any way. This could weaken the structural strength of the components.

Secure and properly block vehicle prior to beginning installation.

Always wear safety glasses when using power tools.

TORQUE SPECIFICATIONS

1/2" Bolts	70 ft. lbs.
7/16" Bolts	60 ft. lbs.
U-Bolts	99 ft. lbs.

INSTALLATION:

1) Raise the vehicle. If working without a shop hoist, support vehicle with suitable safety jack stands. Put vehicle in gear, set emergency brake and block front wheels, in front and behind tires. Place safety jack stands under frame to support vehicle. Remove rear tire and wheel assemblies.

NOTE: Trac-Link Rear Driver Side Mount (20-71800-5) and Passenger side Mount (20-71800-6) are mirror images of each other. Install mount with the notch to clear the axle tube on differential facing down as shown in **Illustration 1**. Flat Side plate on the mount installs towards center of vehicle. Check to make sure the correct mount is installed on correct side of vehicle. Install bolts with heads facing towards outside of vehicle.

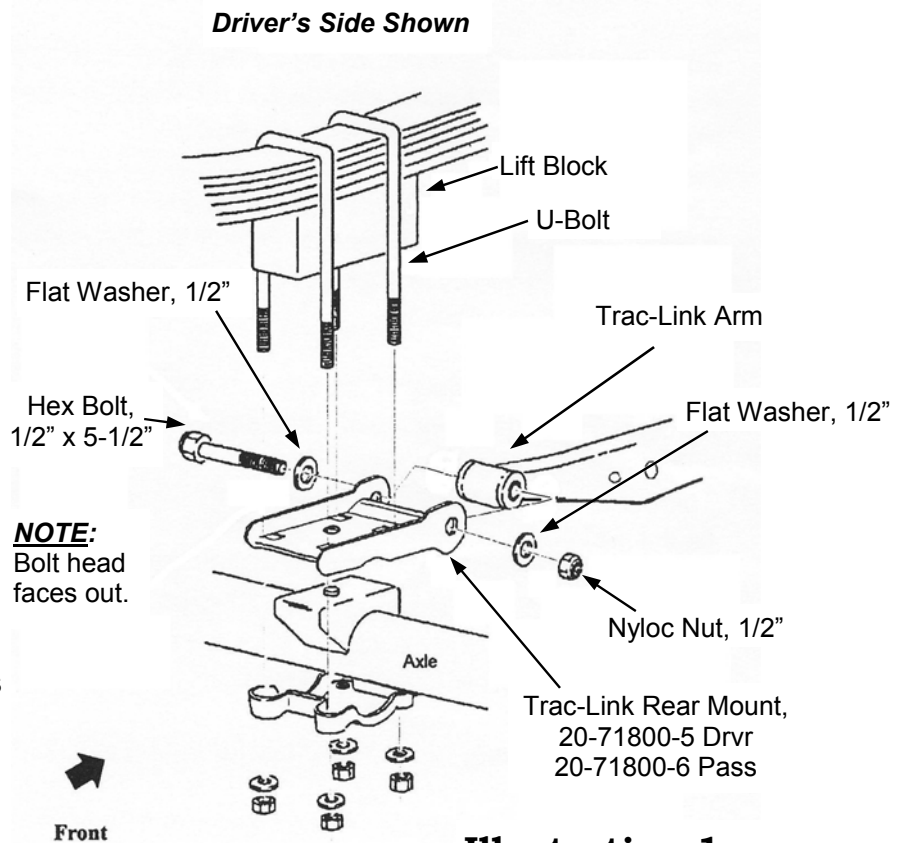
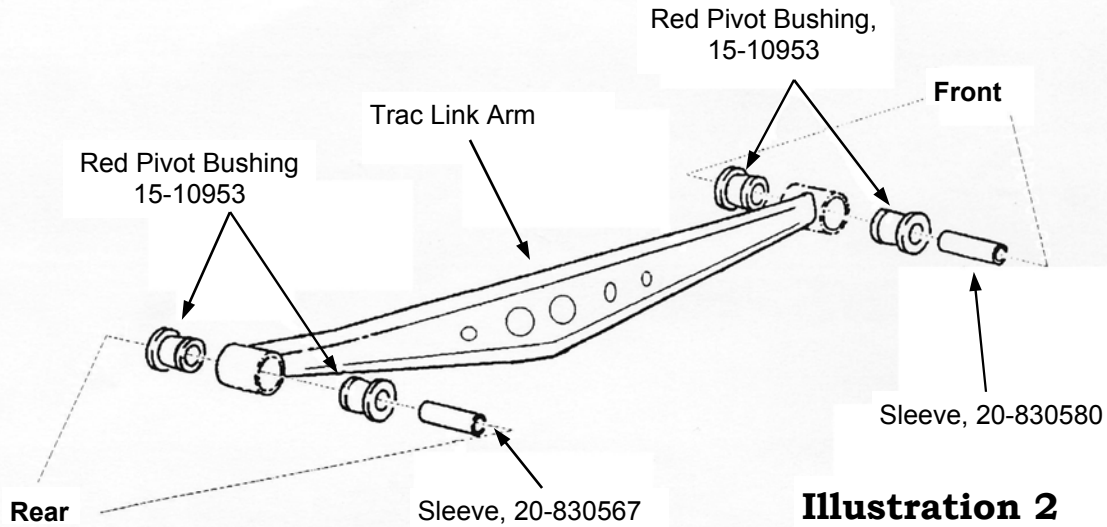

Illustration 1

2) To install the Trac-Link Rear Mount (20-71800-5 Drvr, 20-71800-6 Pass) support the differential with a floor jack. Unbolt U-bolts and lower rear axle enough to insert the Trac-Link Rear Mount between the lift block and axle housing as shown in **Illustration 1**. Verify that the index pin on the lift block passes through Rear Mount and into the hole in the axle housing. Install U-bolts and tighten assembly.



3) Install the Bushings (15-10953) and Sleeves (20-830567, Rear) (20-830580, Front) into the Trac-Link Arm end loops as shown in **Illustration 2**. Use lubricant as necessary.

4) Install Trac-Link Arms into Rear Mounts as shown in **Illustration 1**. Install 1/2" x 5-1/2" Bolt, with bolt head facing out, if possible. If equipped with rear disc brakes there should be at least 1/2" clearance between Bolt head and brake caliper.

NOTE: Make sure all fuel lines, fuel tanks, electrical cables, and other lines are clear before drilling any holes to prevent from damaging anything that may be in the way.

5) Attach Trac-Link Mounts (20-71800-4) to Trac-Link Arms using hardware provided. Replace wheels and lower vehicle so vehicle is at normal ride height. Position Mounts on frame. Use Mount holes as guides to mark locations. Raise vehicle and drill 1/2" holes into frame rails where marked. Install mounts using 7/16" hardware provided as

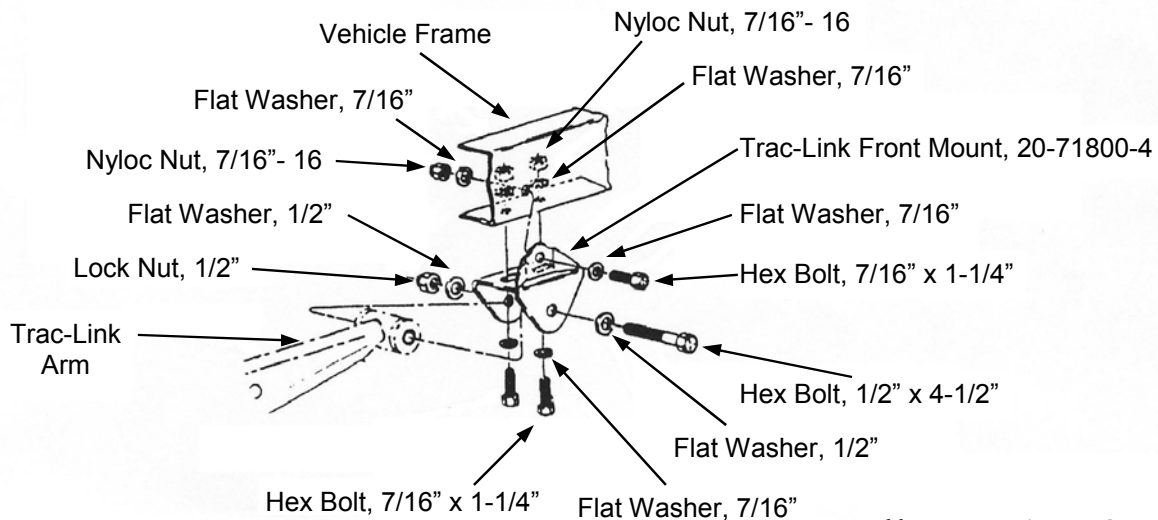

shown in **Illustration 3** and tighten assembly. Tighten 1/2" Link-to-Mount bolts once vehicle is at ride height.

NOTE: Suspension should be cycled up to bumpstop to ensure that Trac-Link does not interfere with other components of the vehicles suspension. Special attention should be give to clearance between Trac-Link and front leaf spring hanger. Adjust bumpstops if necessary.

6) Lower vehicle and torque all bolts as specified in the Torque Specifications chart.