



7/10/13

**1984-2001 JEEP CHEROKEE
4" LONG ARM KIT
P/N: 10-45584
&
6" LONG ARM KIT
P/N: 10-45684**

INSTALLATION INSTRUCTIONS

NOTE: Each lift kit, and options to lift kits, are packaged separately. Therefore installation procedures are covered in separate instructions. Familiarize yourself with each specific set of instructions before beginning.

PART LIST

ITEM	DESCRIPTION	QTY.	ILLUS.
Box 1	All Kits		
20-55584-1	Cherokee 4-Link Bracket, Driver	1	1, 2, 4, 12
20-55584-2	Cherokee 4-Link Bracket, Passenger	1	4
20-72085	Hardware Pack, Front Links		
13-23536-Z	9/16" x 4" Greaseable Bolt	4	12
13-22899-Z	10MM x 90MM Bolt Gr. 10.9	2	12
13-23120-Z	7/16" x 3-1/2" Bolt Gr. 8	2	12
13-30395-Z	9/16" Flat Washer	8	12
13-30642-Z	10MM Flat Washer	4	12
13-30304-Z	7/16" Flat Washer	4	12
13-10930-Z	1-1/4" Jam Nut	2	10
13-10397-Z	9/16" Top Lock Nut	4	12
13-10839-Z	10MM Top Lock Nut	2	12
13-10384-Z	7/16" Top Lock Nut	2	12
13-90815	Cotter Pin	7	
20-70216			
20-834051	Sway Bar Link, Upper Assembly	2	17
20-834064	Sway Bar Link, Lower Loop	2	17
20-834090	Sway Bar Link, Center Tube	2	17
13-30694-Z	Washer, 1-1/4"OD x 1/2"ID	4	17
13-10878-Z	Nut, 1/2" Nyloc	2	17
15-11746	Bushing, Sway Bar Flex Joint	4	17
15-11083	Bushing, Hour Glass	2	17
20-831451	Sleeve, 5/8" x 1-1/2"	2	17
13-90984	Pin, Safety	4	17
20-71539	Hardware Pack, Front Bumpstop Pads		
20-55497-2	Bumpstop Pad	2	14
13-22145-Z	3/8" x 2" Bolt, Self Tapping	2	14
20-70603	Hardware Pack, Front Brake Lines		
50-55697-1	Front Brake line	2	
50-55697-2	Brake Line Bracket	2	
50-55697-3	Brake Line Screw, Self Tapping	2	
50-5700-2	Brake Line Clip	2	
50-5700-4	Brake Line Crush Washer	4	
20-68305	Hardware Pack (Universal)		
13-20447-Z	Unslot Hex, #10 x 1/2"	4	

PART LIST

ITEM	DESCRIPTION	QTY.	ILLUS.
15-10966	Clamp, 3/8" x 3/8" x .203"	4	
15-11395	Wire Tie, 6"	4	
15-11447	Wire Tie, 8"	2	
15-11460	Wire Tie, 11"	2	
15-12188	Rear Extended Bumpstop	2	23
20-72072	Hardware Pack, Rear Brake Line Bracket		
20-55484-4	Cherokee Rear Brake Line Bracket	1	22
13-21157-Z	5/16" x 3/4" Bolt	1	22
13-30187-Z	5/16" Flat Washer	2	22
13-10155-Z	5/16" Nyloc Nut	1	22
20-72215	Hardware Pack, Sway Bar Axle Brackets		
20-55584-6	Sway Bar Axle Bracket	2	16
13-21027-Z	12MM x 70MM Bolt	2	
13-10696-Z	12MM Top Lock Nut	2	
13-30117-Z	12MM Flat Washer	2	
Box 2	10-45584		
20-20361-1	Front Coil Spring, 4"	2	14, 15
Box 2	10-45684		
20-20322-1	Front Coil Spring, 6"	2	14, 15
Box 3	All Kits		
20-55584-3	Cherokee Transmission Crossmember	1	3, 4, 5
20-55584-4	Cherokee Transfer Case Skid Plate	1	3, 4
20-55584-5	Cherokee Transfer Case Skid Support	1	5
20-72059	Hardware Pack, 4-Link Brackets & Crossmember		
13-22938-Z	3/8" x 1-1/4" Bolt	14	3, 4, 5
13-24056-Z	3/8" x 6" Bolt	2	2
13-21417-Z	3/8" x 5" Bolt	2	2
13-22756-Z	10MM x 30MM Bolt	4	4
13-23978-Z	1/4" x 1" Self Drilling Screw	18	2
13-21352-Z	1/4" x 1" Bolt	2	2
13-10553-Z	3/8" Top Lock Nut	18	3, 4, 5
13-10161-Z	1/4" Nyloc Nut	2	2
13-30408-Z	3/8" Flat Washer	36	3, 4, 5

PART LIST

ITEM	DESCRIPTION	QTY.	ILLUS.
13-30642-Z	10MM Flat Washer	4	4
13-30195-Z	1/4" Flat Washer	4	2
20-835553	3/4" x 3-7/16" Sleeve	2	2
20-835566	3/4" x 4" Sleeve	2	2
Box 4	All Kits		
20-55697-1	Front Lower Link	2	10, 12
20-55697-18	Lower Link Adjuster	2	10, 12
20-55697-2	Front Upper Link, Driver	1	11, 12
20-55697-17	Front Upper Link, Passenger	1	
20-55697-5	Front Track Bar	1	13
20-834285	Rod End, Track Bar (With Nut & Cotter Pin)	1	13
Box 5	10-45584		
20-55484-3	Rear Shackle	2	19
20-72007	Hardware Pack, Shackle Bushings		
15-12162	Shackle Bushing	4	19
20-835527	3/4" x 2-13/16" Sleeve	2	19
13-70182	Cherokee Rear Add-A-Leaf	2	20
20-72202	Hardware Pack, Center Bolts		
13-91517	5/16" x 3" Center Bolt with Nut	2	20
Box 5	10-45684		
13-70195	Cherokee Leaf Spring Pack	1	21
13-90919	U-Bolt, 1/2" x 3" x 8" Round	4	21
20-65991	Hardware Pack, U-Bolt Hardware		
13-30382	1/2" Flat Washer	8	21
13-10332	1/2" High Nut	8	21
Box 6	10-45584		
24-188197	Cherokee Front Shock, 4" Lift	2	15
33-066868	Cherokee Rear Shock	2	
Box 6	10-45684		
13-70195	Cherokee Leaf Spring Pack	1	21

PART LIST

ITEM	DESCRIPTION	QTY.	ILLUS.
Box 7	10-45684		
BE5-C016-T0	Cherokee Front Shock, 6" Lift	2	15
33-066868	Cherokee Rear Shock	2	

INTRODUCTION

Installation by a professional mechanic is recommended. Use of the appropriate tools, a Jeep service manual, and a shop hoist can greatly reduce installation time.

Prior to installation, carefully inspect the vehicle's steering and drive train systems, paying close attention to the tie-rod ends, pitman arm, ball joints and wheel bearing preload. Also check steering-to-frame and suspension-to-frame attachment points for stress cracks. The overall vehicle must be in excellent working condition; repair or replace worn parts.

Read instructions carefully and study illustrations before attempting installation. **RCD Suspension** is not responsible for damage, failure or injury resulting from improper installation or parts substitution of this kit.

Check parts and hardware against the parts list to assure that your kit is complete. The parts and hardware supplied are of high-grade material and must not be replaced by inferior parts or failure may result. Do not begin installation if parts are missing.

Separate parts according to the areas where they will be used. Placing the hardware with brackets before you begin will save installation time.

This kit is supplied as a bolt-on assembly. Do not weld anything to the components and do not weld the components to the vehicle.

All components in this kit come with a protective coating. Do not plate (i.e. chrome, cadmium, zinc etc.) or otherwise alter the finish in any way. This could decrease the structural strength of the components.

Secure and properly block vehicle prior to beginning installation.

Always wear safety glasses when using power tools.

Foot-Pound torque readings are listed on the Torque Specifications chart at the end of the instructions unless specifically stated in an instruction. **DO NOT USE AN IMPACT WRENCH TO TIGHTEN ANY OF THE BOLTS.**

PLEASE NOTE

WARNING: DO NOT USE WHEEL SPACERS

Front-end realignment is necessary.

Speedometer recalibration is necessary if larger tires (10% more than stock diameter) are installed.

Brake system will need to be bled by a professional brake technician.

4" System is designed to accommodate up to a 31" x 10.5" tire on a wheel size of 15" x 7" with a maximum of 4.5" backspacing.

6" System is designed to accommodate up to a 33" x 12.5" tire on a wheel size of 15" x 8" with a maximum of 4.5" backspacing.

Special tools are required for safe removal and installation of the ball joints, tie-rods and torsion bars. These tools can be purchased from your Jeep Dealer.

Tool (Puller P/N C-3894-A)

Front Installation Instructions

1. Raise and support vehicle with jack-stands under front axle and in front of rear spring perch. Remove wheels and tires.
2. Place jack under transmission and remove transmission mount nuts. Then remove transmission crossmember to frame bolts and nuts. Raise transmission. Remove crossmember.
3. Working on one side at a time, place 4-Link Bracket (20-55584-1) on frame using transmission crossmember hardware removed (**Illustration 1**).

Illustration 1

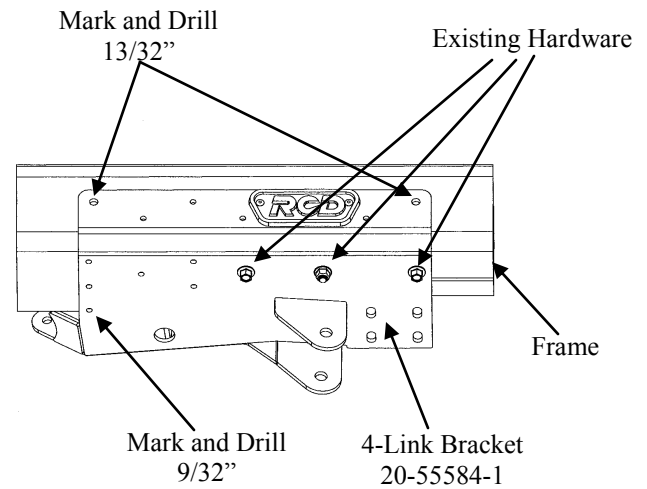

NOTE: On some models it may be necessary to tap the front hole to 10MM-1.5

4. Mark location of two holes for long 3/8" bolts and 1/4" bolt. Remove 4-Link Bracket and drill two holes marked through both sides of frame to 13/32". Then open up the outer hole to 3/4". A step drill works good for this. Also drill one 9/32" hole marked. (**Illustration 1**)

CAUTION: Be careful to not damage brake and fuel lines on back side of frame.

5. Insert Sleeves (20-835553 & 20-835566) into 3/4" holes drilled. The longer sleeve goes in the front hole.
6. Place 4-Link Bracket back on frame and temporarily install 10MM x 30MM Bolts (13-22756-Z) into bottom of frame. Install original Nut on existing stud. Install bolts 3/8" x 6" (13-24056-Z) and 3/8" x 5" (13-21417-Z) in their corresponding holes (**Illustration 2**). Torque Nut to 30ft. Lbs.
7. Install all Self Drilling Screws (13-23978-Z) and 1/4" x 1" Bolt (13-21352-Z), Nut (13-10161-Z) and Washers (13-30195-Z).

Illustration 2

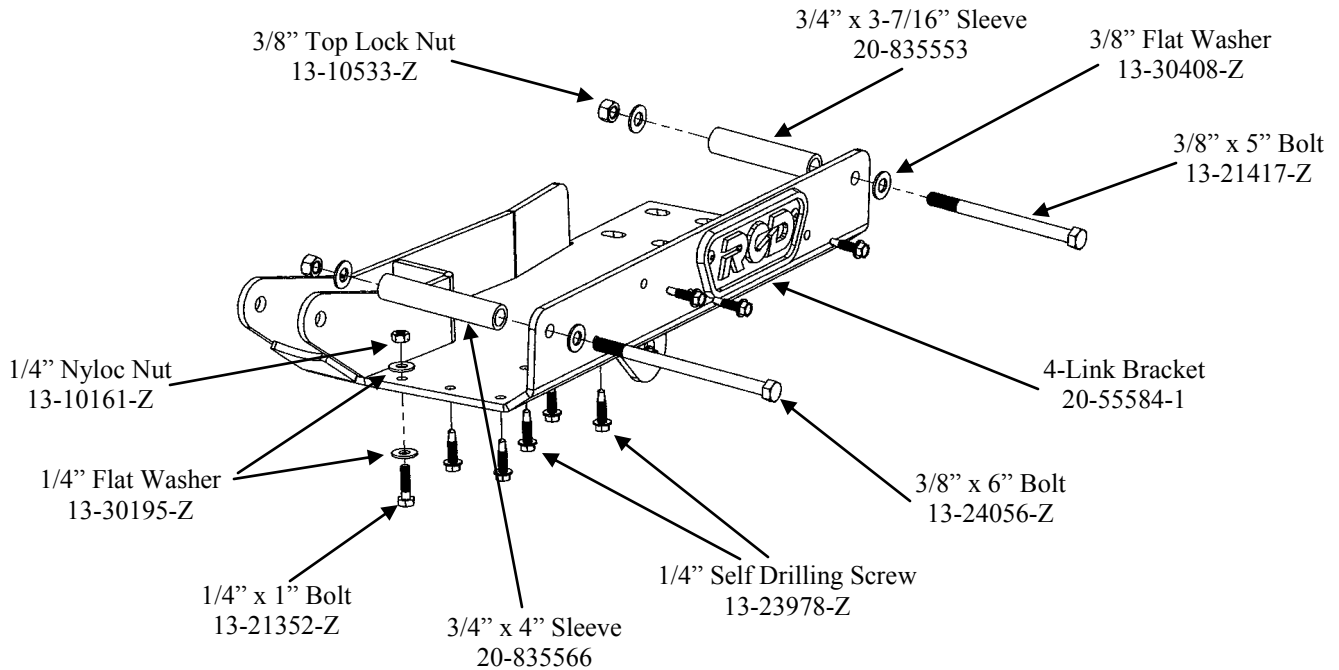

8. Remove 10MM Bolts previously installed.

9. Repeat steps 4 thru 7 on opposite side.

10. Install Transfer Case Skid Plate (20-55584-4) onto Transmission Crossmember (20-55584-3) using 3/8" x 1-1/4" Bolts (13-22938-Z), Nuts (13-10553-Z) and Washers (13-30408-Z). Tighten until just snug. (**Illustration 3**).

Illustration 3

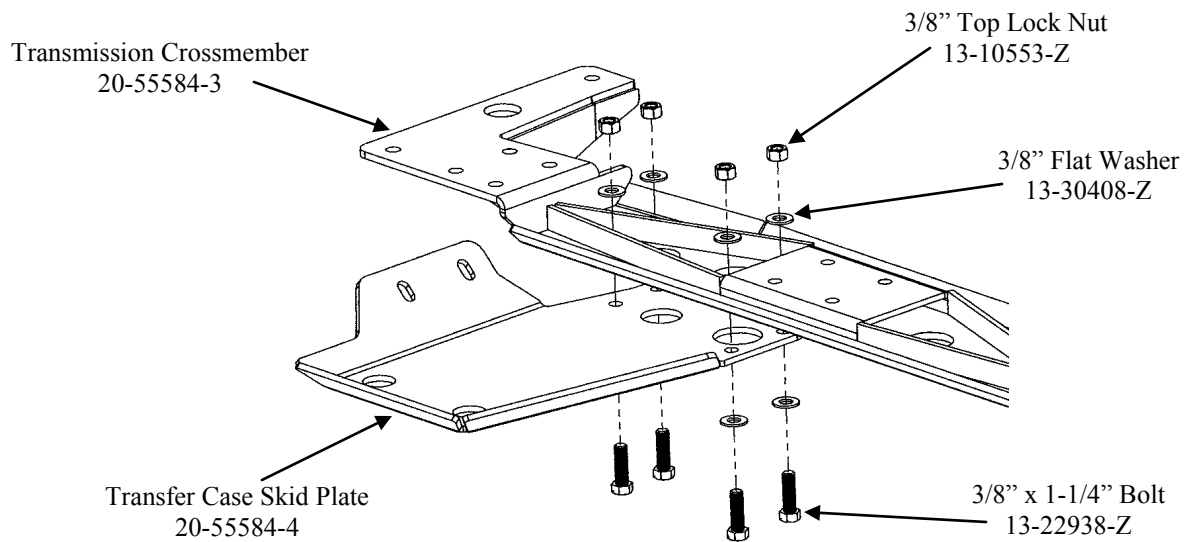

11. Install Transmission Crossmember onto vehicle using 10MM x 30MM Bolts (13-22756-Z) and Washers (13-30642-Z) and 3/8" x 1-1/4" Bolts (13-22938-Z) Nuts (13-10553-Z) and Washers (13-30408-Z). **(Illustration 4)**. Do Not install two outer 3/8" x 1-1/4" Bolts on Drivers side at this time. Torque 10MM Bolts to 30 ft. lbs. and 3/8" Bolts to 35 ft. lbs.

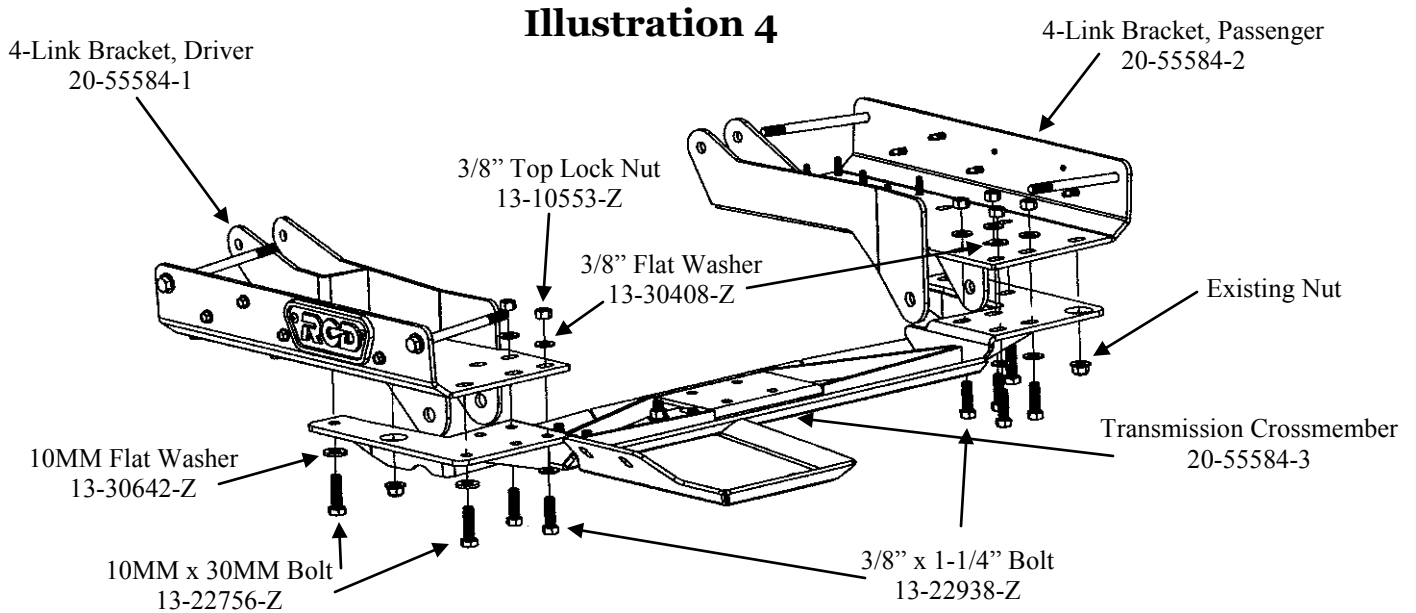

12. Install Transfer Case Skid Support (20-55584-5) using 3/8" x 1-1/4" Bolts (13-22938-Z), Nuts (13-10553-Z) and Washers (13-30408-Z). **(Illustration 5)** Torque all 3/8" Bolts to 35 ft. lbs.

13. Line up transmission mount studs with holes in Transmission Crossmember and lower Transmission. Install nuts previously removed. Torque nuts to 25 ft. lbs.

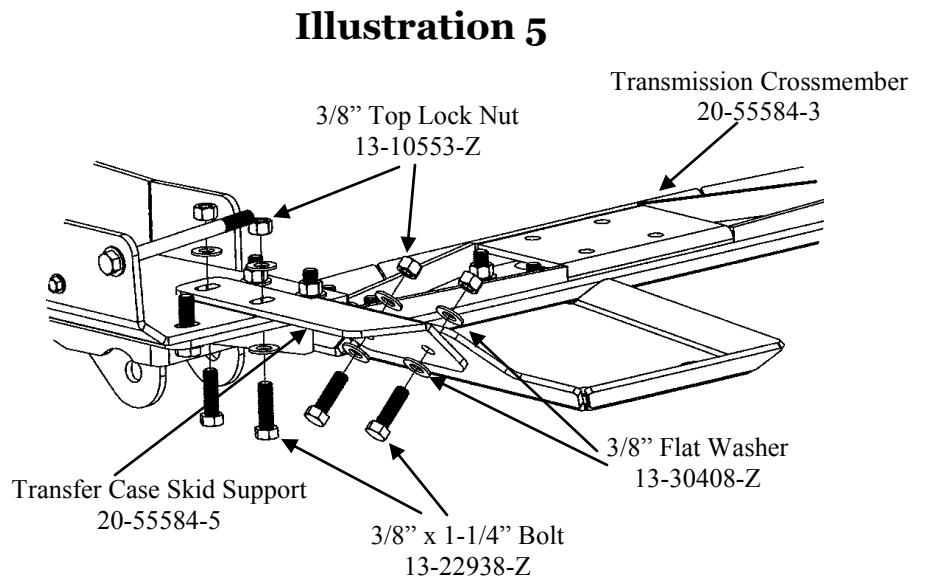

14. Place jack under front axle and remove jack stands. Support vehicle with jack stands under 4-Link brackets installed. Do not block access to new Lower Control Arm Pivot.

15. Place reference marks on the front drive shaft and axle. Disconnect the front drive shaft from axle. **(Illustration 6)**

16. Remove front shock absorbers. Disconnect and remove stabilizer links.

17. Disconnect Trac Bar at both ends and remove from vehicle.

18. Disconnect Steering Link from Pitman Arm. **(Illustration 7)**

19. Locate and remove the two bolts attaching each Brake Caliper to the Steering Knuckles. Remove the Calipers and hang out of the way with a length of wire, careful not to damage the brake hose. **DO NOT let the caliper hang by the brake hose.**

20. Lower axle until coil spring is free from upper mount. Remove coil spring retainer bolt and remove the coil spring.

21. Remove Upper and Lower Suspension Links. Lower axle and move out of way.

22. Using a suitable cutting tool. Remove both Lower Link Frame Brackets. **(Illustration 8)**

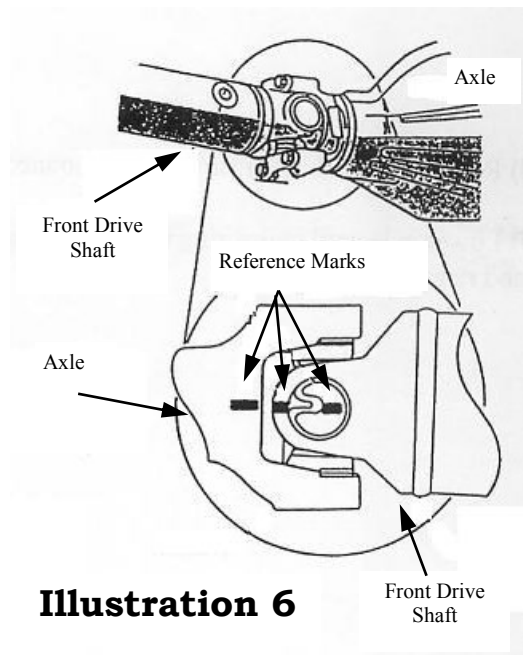

Illustration 6

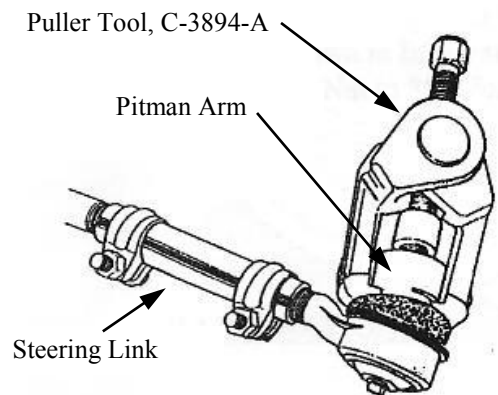
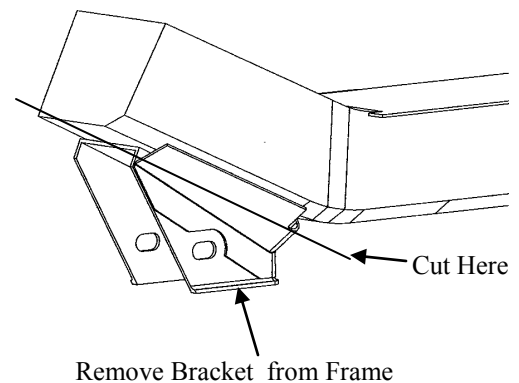

Illustration 7

Illustration 8



23. Remove Lower Half of both Upper Link Brackets.
Paint all bare metal. **(Illustration 9)**

Illustration 9

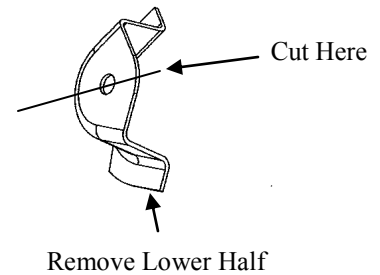

24. Assemble Lower Link Adjusters (20-55697-18) to Lower Links (20-55697-1) with 1-1/4" Jam Nut (13-10930-Z). **(Illustration 10)**

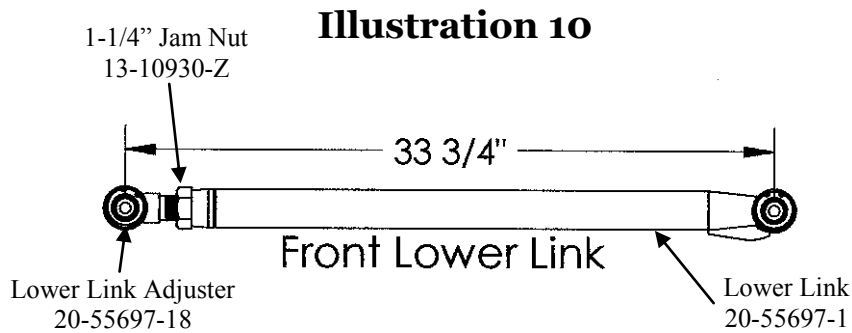

25. Attach Upper Links (20-55697-2 and 20-55697-17) to 4-Link Brackets using 7/16" x 3-1/2" Bolt (13-23120-Z) Nut (13-10384-Z) and Washers (13-30304-Z) provided. **(Illustration 12)** Note that Upper Arms have a slight offset to them. **(Illustration 11)** Torque Bolts to 60 ft. lbs.

Illustration 11

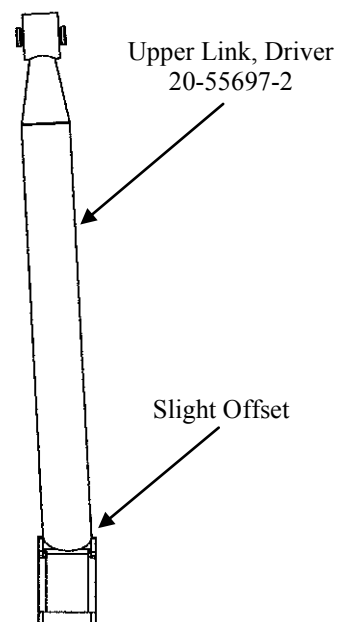

26. Position Front Axle under vehicle and attach to Upper Links using 10MM x 90MM Bolts (13-22899-Z) Nuts (13-10839-Z) and Washers (13-30642-Z). **(Illustration 12)** Do not tighten at this time.

27. Attach Lower Links to Frame and Axle using 9/16" x 4" Greaseable Bolts (13-23536-Z) Nuts (13-10397-Z) and Washers (13-30395-Z). **(Illustration 12)** Torque Bolts to 100 ft. lbs.

Illustration 12

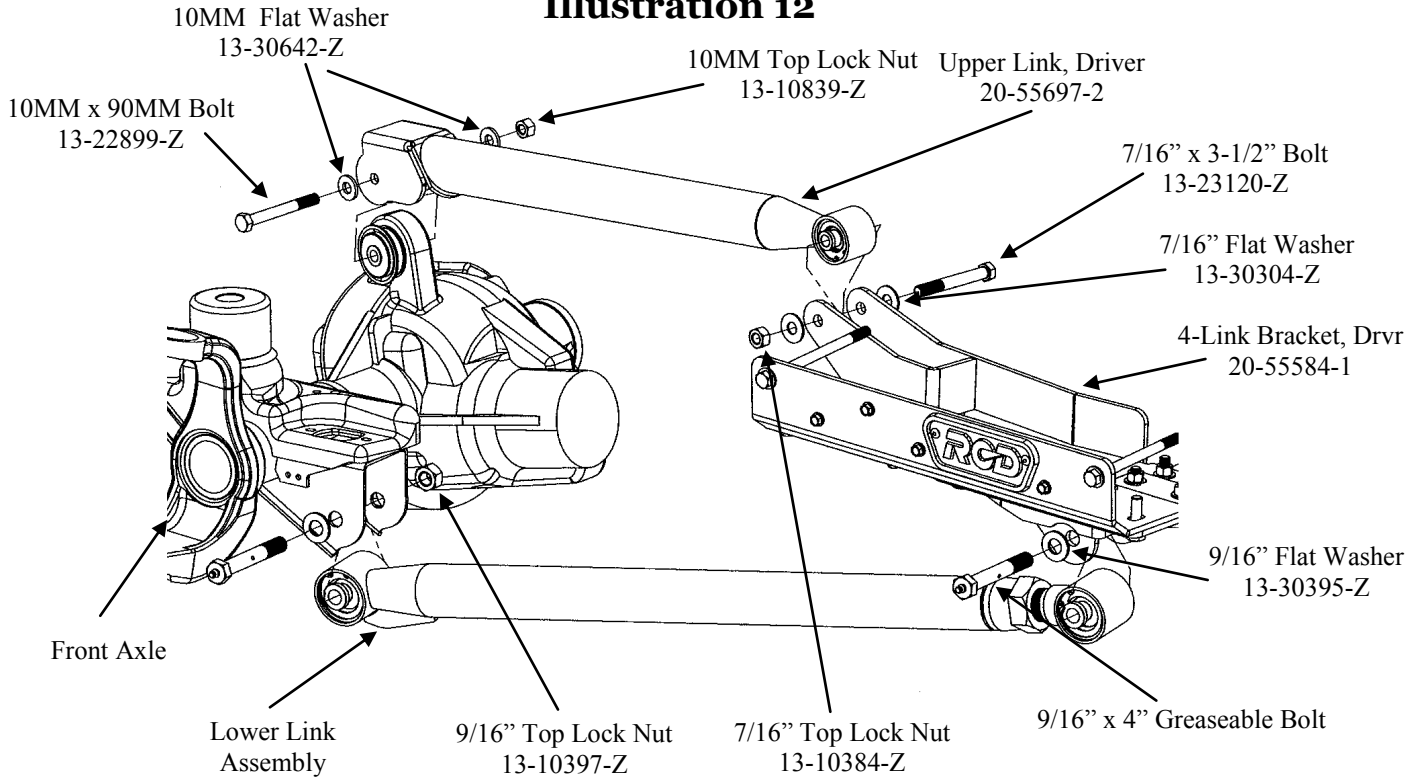

28. Thread Rod End (20-834285) with Jam Nut into Trac Bar (20-55697-5) until there are no threads showing.

29. Install Trac Bar on Vehicle using existing hardware at axle and new nut and cotter pin at frame. (Illustration 13)

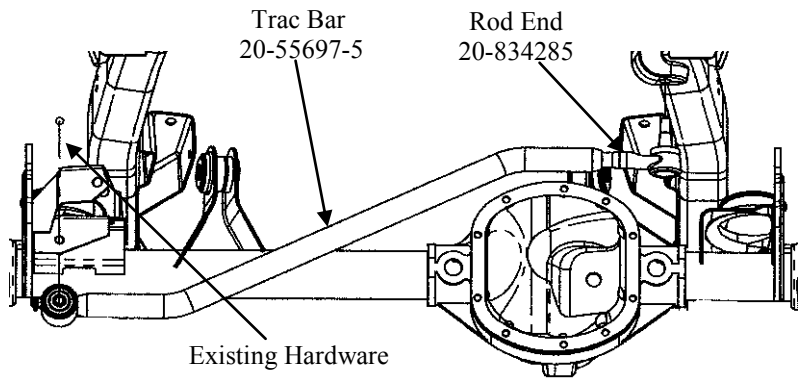

Illustration 13

30. Install new Bumpstop Pad (20-55497-2) as shown in **(Illustration 14)**. Mark center of lower coil spring pad. Using an 11/32" diameter drill bit, drill a pilot hole in the previously marked area. Install using 3/8" self-tapping hardware provided. Torque to 30 ft. lbs.

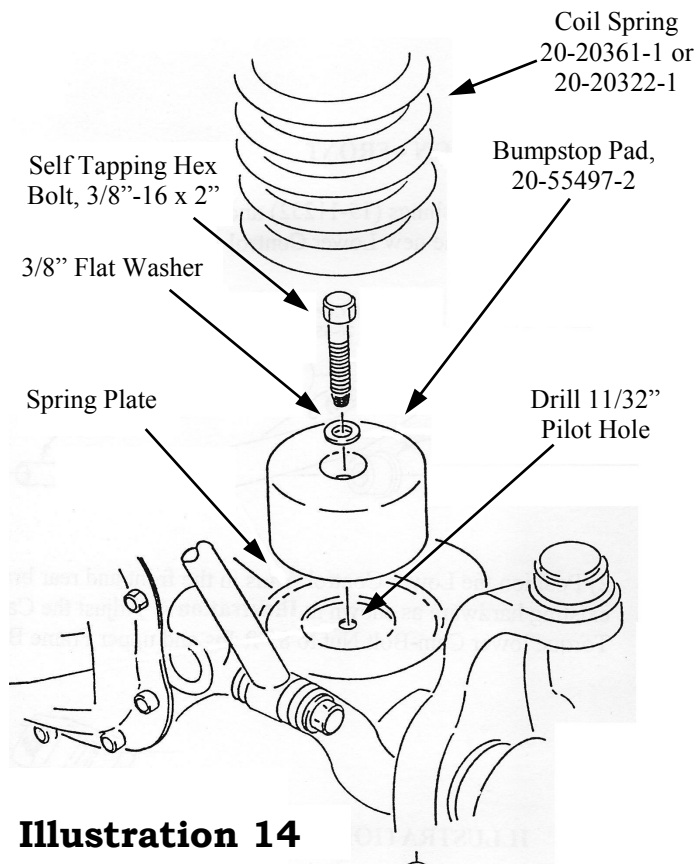

Illustration 14

31. Position new front coil spring (20-20361-1) 4" or (20-20322-1) 6" on axle pad. Re-install coil spring retainer and bolt. Torque to 16 ft. lbs.

32. Raise axle into position making sure BOTH coil springs seat in upper mounts, then raise axle another 2". Install new longer shock absorbers (24-188197) 4" or (BE5-C016-T0) 6" as shown. **(Illustration 15)**. Tighten upper shock nut until snug and rubber is properly compressed. Torque lower shock bolts to 20 ft. lbs.

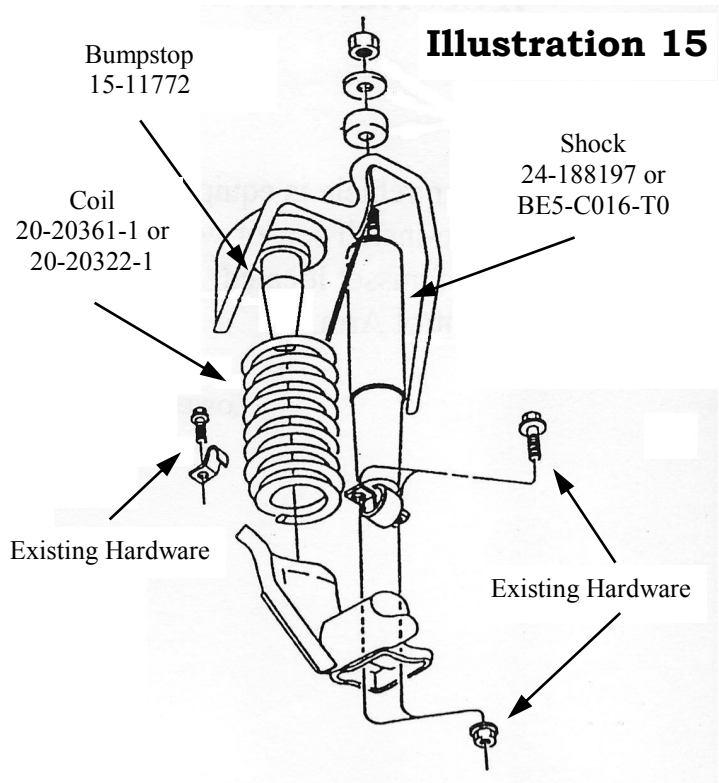

Illustration 15

33. Re-attach Drag Link to Pitman Arm. Torque nut to 55 ft. lbs. Install new cotter pin.

34. Re-attach Brake Calipers to Front Knuckles. It may be necessary to disconnect brake hose. Torque bolts to 11 ft. lbs.

35. Install new Brake Hoses (50-55697-1) with angle bracket, clip, and crush washers provided. Attach Angle Bracket with existing hardware.
Check to make sure brake Hoses Clear all components when wheels are turn and suspension is cycled.

36. Using a suitable cutting tool. Remove Sway Bar Axle Brackets and Weld on new Sway Bar Axle Brackets (20-55584-6). **(Illustration 16) Make note of bracket position before removal.**

Illustration 16

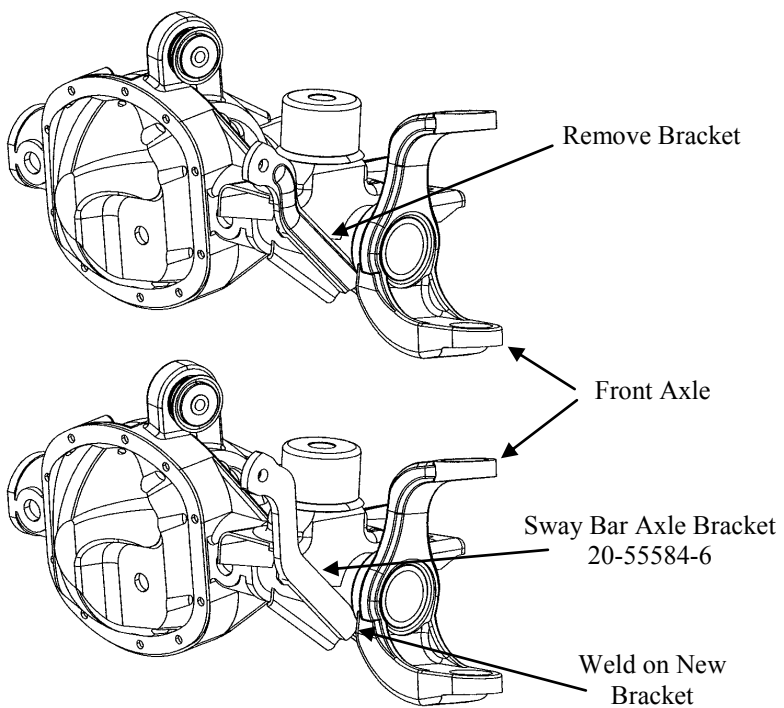

37. Assemble Front Sway Bar Links. **(Illustration 17)**

38. Using a 1/2" diameter drill bit, drill out hole in Sway Bar to accept Sway Bar Link.

39. Install Sway Bar Links to Axle Brackets using 12MM x 70MM Bolt (13-21027-Z) Nut (13-10696-Z) and Washer (13-30117-Z) and to Sway Bar using Washers (13-30694-Z) Bushings (15-11746) and Nut (13-10878-Z). Torque Bolt to 70 ft. lbs. and Upper Nut until snug.

40. Install Wheels and Tires and lower vehicle to ground. Torque lug nuts to 80 ft. lb.

Illustration 17

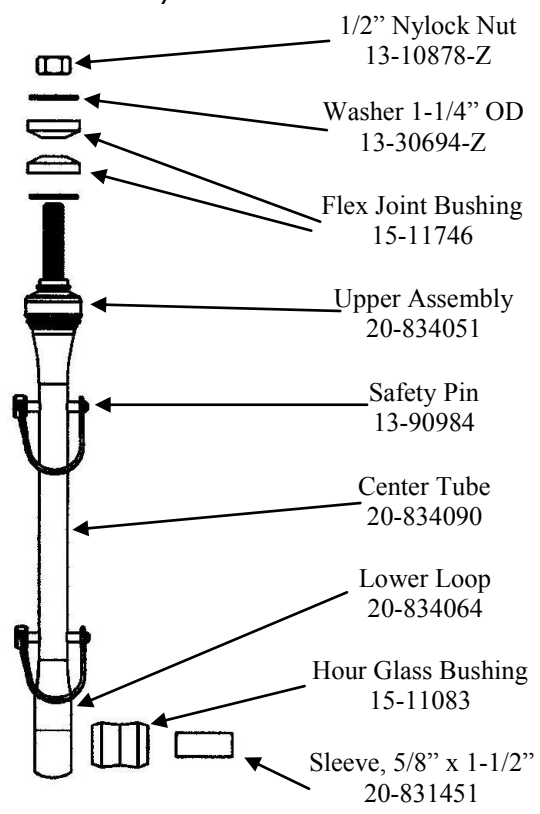

Rear Installation Instructions

1. Make sure frame is still securely supported by jack-stands on frame right in front of rear leaf spring mounts. Support rear axle with jack and remove rear tires.

2. Remove rear shock absorbers.

3. Locate place where rear brake line attaches to chassis. Remove clip retaining brake line and pull line free from bracket.

4. Lower rear axle until there is no tension on rear leaf springs.

5. If installing 6" Kit skip to step #14.

6. Remove upper and lower shackle bolts and remove shackles. **(Illustration 18)**

7. Insert Bushings (15-12162) and Sleeves (20-835527) into new Shackles (20-55484-3) and install using original hardware. **(Illustration 19)** Torque bolts to 130 ft. lbs.

Illustration 18

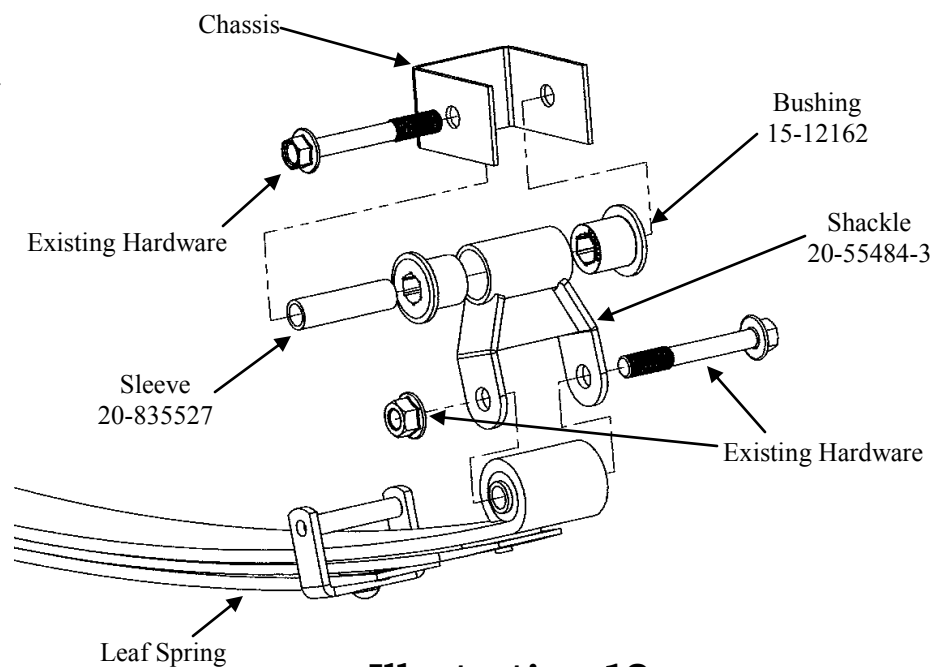
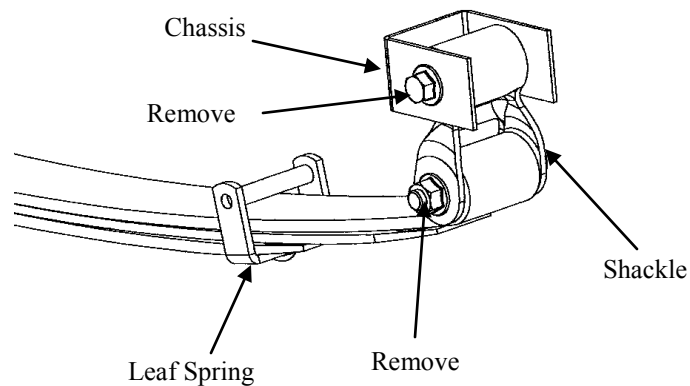

Illustration 19

8. Remove U-bolts attaching rear axle to driver side leaf spring. Carefully lower rear axle.

CAUTION: Do not allow axle to hang by any hoses or cables.

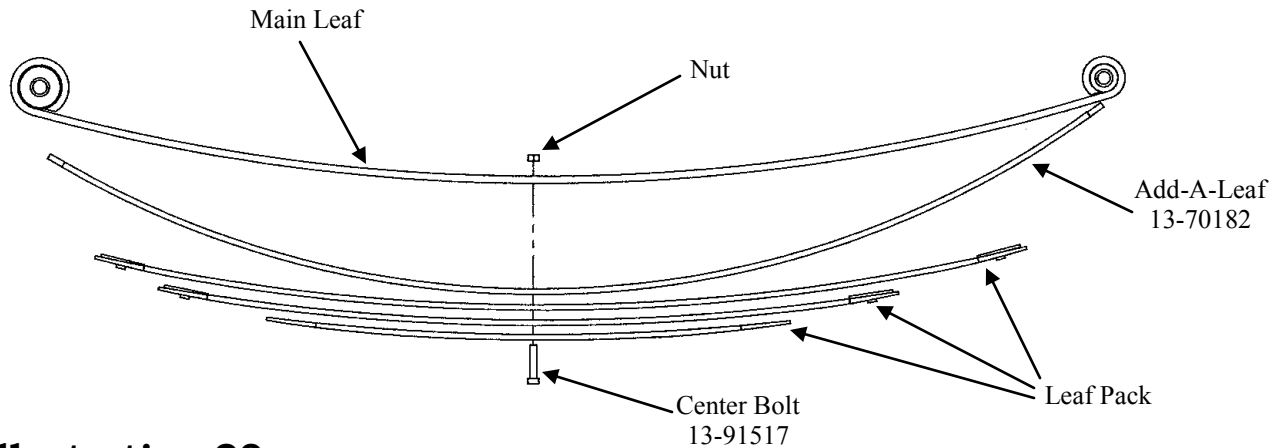

Illustration 20

9. Hold the spring assembly securely together with C-Clamps. Remove any spring leaf alignment clamps. Remove the spring center bolt. If necessary, use a hammer and punch to drive it out.
10. Apply a small amount of grease to the end of the Add-a-Leaf. Place leaf in the spring assembly as shown (**Illustration 20**) and reassemble the leaf spring using C-Clamps.

CAUTION: Do not try to compress the spring with the center bolt.

11. Insert the new Center Bolt (13-91517). Torque to 20 ft. lbs.
12. Re-mount axle to spring using existing U-Bolts and Nuts. Torque nuts to 100 ft. lbs.
13. Repeat steps 7 thru 11 on opposite side. Skip to step 18.

14. **On 6" Kit only.** Remove U-Bolts attaching Rear Axle to Leaf Springs. Carefully lower Rear Axle.
15. Remove Front Spring Eye Bolts and Rear Spring to Shackle Bolts and remove springs.
16. Install New Rear Leaf Springs (13-70195) to frame and shackle, using existing hardware previously removed. **(Illustration 21)**. Do not tighten at this time.
17. Raise Axle into place and attach to Springs using U-Bolts (13-90919) Nuts (13-10332) and Washers (13-30382) provided. **(Illustration 21)**. Torque U-Bolts to 90 ft. lbs.

Illustration 21

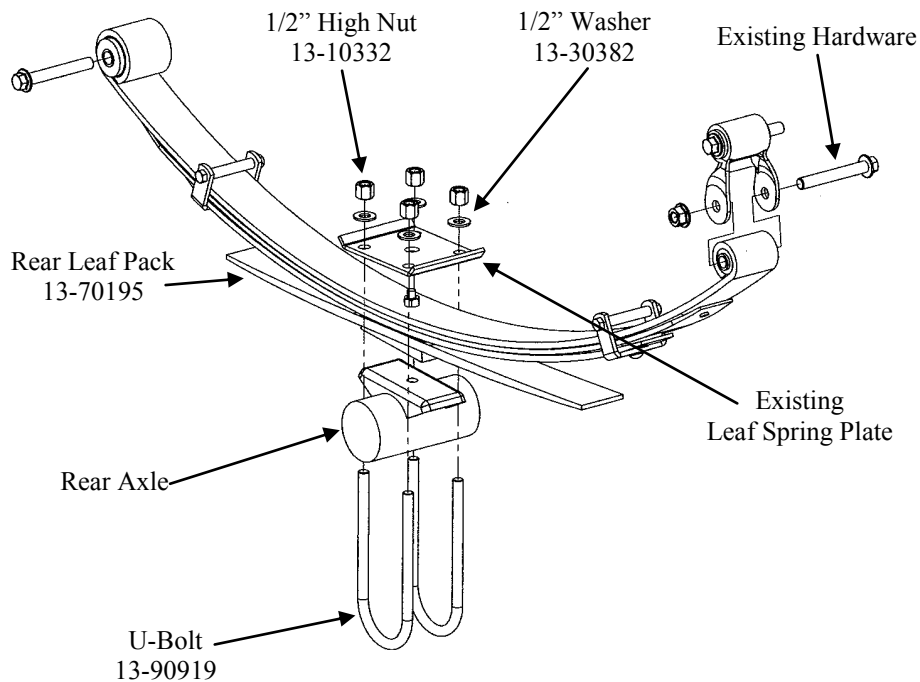

18. Install new longer Shock Absorbers (33-066868). Tighten upper bolts to 20 ft. lbs. Tighten lower nut until bushing is compressed.

19. Install Brake Line Drop Bracket (20-55484-4) to original bracket as shown **(Illustration 22)**

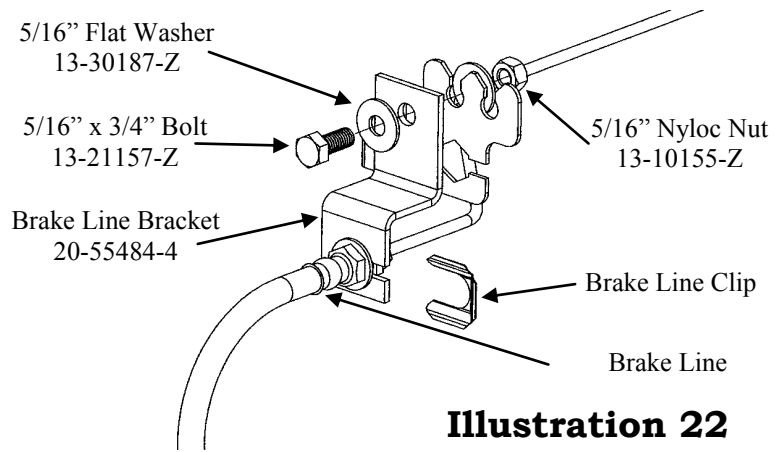
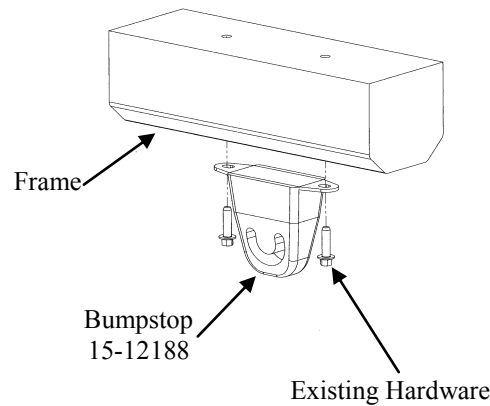

Illustration 22

20. Install Extended Rear Bumpstops to frame using existing hardware. **(Illustration 23)** Torque bolts to 20 ft. lbs.

Illustration 23



21. Cycle and inspect steering, suspension and driveline systems for proper operation, tightness and adequate clearance. Bleed Brakes. Recheck brake hose/fittings for leaks. Be sure all hoses are long enough and do not rub suspension components or tire.

22. Install the wheels and tires. Remove the jackstands and lower the vehicle.

23. Once vehicle is on ground, at ride height torque front upper control arm-to-axle bolts to 55 ft. lbs. Torque rear leaf spring-to-body, rear leaf spring-to-shackle and shackle-to-body bolts to 100 ft. lbs.

Torque Specifications

General Torque Specifications:

5/16"	20 ft. lbs.	M6	9 ft. lbs.
3/8"	35 ft. lbs.	M8	23 ft. lbs.
7/16"	60 ft. lbs.	M10	45 ft. lbs.
1/2"	90 ft. lbs.	M12	75 ft. lbs.
9/16"	160 ft. lbs.	M14	120 ft. lbs.
5/8"	175 ft. lbs.	M16	165 ft. lbs.
3/4"	250 ft. lbs.	M18	220 ft. lbs.

Existing Hardware Torque Specifications:

Brake Caliper Mounting Bolt	11 ft. lbs.
Universal Joint Strap Bolt	14 ft. lbs.
Drag Link to Pitman Arm Stud Nut	35 ft. lbs.
Antiroll Bar Link to Axle Bracket Nut	70 ft. lbs.
Lower Control Arm Nut, to Axle	130 ft. lbs.
Lower Control Arm Nut, to Frame	130 ft. lbs.
Upper Control Arm Nut, at Axle	55 ft. lbs.
Upper Control Arm Nut, at Frame	55 ft. lbs.
Front Shock Absorber Lower Bolt	20 ft. lbs.
Track Bar to Axle Bracket Bolt/Nut	74 ft. lbs.
Track Bar to Frame Bracket Stud Nut	60 ft. lbs.
Leaf Spring Eye to Body Bolt	100 ft. lbs.
Transmission Crossmember to Frame Bolts and Nut	30 ft. lbs.
Transmission Mount to Transmission Crossmember Nuts	25 ft. lbs.
Leaf Spring Shackle to Body Bolt	100 ft. lbs.
Leaf Spring Shackle Bolt/Nut	95 ft. lbs.
Rear Shock Absorber Lower Stud Nut	44.0 ft. lbs.
Leaf Spring U-Bolt Nut	100 ft. lbs.