



11/19/14

**2007-2015 JEEP WRANGLER
2" SUSPENSION SYSTEM
P/N: 10-45207**

INSTALLATION INSTRUCTIONS

NOTE: Each lift kit, and options to lift kits, are packaged separately. Therefore installation procedures are covered in separate instructions. Familiarize yourself with each specific set of instructions before beginning.

PART LIST

<u>ITEM</u>	<u>DESCRIPTION</u>	<u>QTY.</u>	<u>ILLUS.</u>
Box 1 of 3			
15-12266	Front Coil Spring Spacer, 2"	2	
15-12279	Rear Coil Spring Spacer, 3/4"	2	
20-72566	Hardware Pack (Front Brake Line Drops)		
20-55407-3	Brake Line Drop	4	5,7
13-21352-Z	Hex Bolt, 1/4"-20 x 1"	4	5,7
13-10161-Z	Nut, 1/4"-20 Nylon Insert Lock	4	5,7
13-30195-Z	Washer, 1/4" Flat	8	5,7
20-72579	Hardware Pack (Sway Bar Links)		
20-55207-1	Sway Bar Link	2	3
15-11083	Hour Glass Bushing	4	3
20-831451	Sleeve, 5/8" x 12MM x 1.48"	4	3
13-21027-Z	Hex Bolt, 12MM-1.75 x 70MM	4	4
13-10696-Z	Nut, 12MM-1.75 Top Lock	4	4
13-30117-Z	Washer, 12MM Flat	8	4
Box 2 of 2			
24-146708	Front Shock	2	
24-146715	Rear Shock	2	

INTRODUCTION

Installation by a professional mechanic is recommended. Use of the appropriate tools, a Jeep service manual, and a shop hoist can greatly reduce installation time.

Prior to installation, carefully inspect the vehicle's steering and drive train systems, paying close attention to the tie-rod ends, rack & pinion unit, ball joints and wheel bearing preload. Also check steering-to-frame and suspension-to-frame attachment points for stress cracks. The overall vehicle must be in excellent working condition; repair or replace worn parts.

Read instructions carefully and study illustrations before attempting installation. **RCD Suspension** is not responsible for damage, failure or injury resulting from improper installation or parts substitution of this kit.

Check parts and hardware against the parts list to assure that your kit is complete. The parts and hardware supplied are of high-grade material and must not be replaced by inferior parts or failure may result. Do not begin installation if parts are missing.

Separate parts according to the areas they will be used. Placing the hardware with brackets before you begin will save installation time.

This kit is supplied as a bolt-on assembly. Do not weld anything to the components and do not weld the components to the vehicle.

All components in this kit come with a protective coating. Do not plate (i.e. chrome, cadmium, zinc etc.) or otherwise alter the finish in any way. This could decrease the structural strength of the components.

Secure and properly block vehicle prior to beginning installation.

Always wear safety glasses when using power tools.

Foot-Pound torque readings are listed on the Torque Specifications chart at the end of the instructions unless specifically stated in an instruction. **DO NOT USE AN IMPACT WRENCH TO TIGHTEN ANY OF THE BOLTS.**

PLEASE NOTE

WARNING: DO NOT USE WHEEL SPACERS

Front-end realignment is necessary.

Speedometer recalibration is necessary if larger tires (10% more than stock diameter) are installed.

System is designed to accommodate up to a 33" x 12.50" tire on a wheel size of 17" x 9" with a maximum of 4.5" backspacing.

Special tools are required for safe removal and installation of the ball joints, tie-rods and torsion bars. These tools can be purchased from your Jeep Dealer.

Recalibration of the ESC system will need to be performed. See the vehicle owners manual.

Front Installation Instructions

1. Raise the front of the vehicle. If working without a shop hoist, support vehicle with suitable safety jack stands. Put vehicle in gear, set emergency brake and block rear wheels, both in front and behind tires. Loosen front wheel lug nuts. Place floor jack under the front axle and raise vehicle. Place safety jack stands under frame rails, just behind lower control arm mounts, and lower the frame onto the stands. Remove wheels.
2. Using a suitable floor jack, raise the jack just enough to support the front axle's weight. Remove the sway bar end links. (Illustration 1)
3. Remove bolts attaching Brake Lines to frame. Disconnect ABS wires from Brake Lines.
4. Remove Front Shocks and then lower Front Axle until Springs are free from upper mount. Remove Springs. (Illustration 2)

Illustration 1

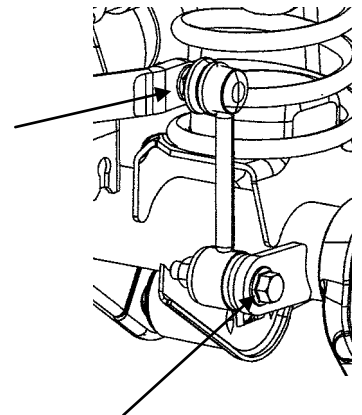

Illustration 2

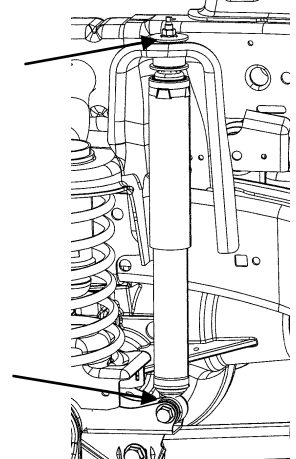

Illustration 3

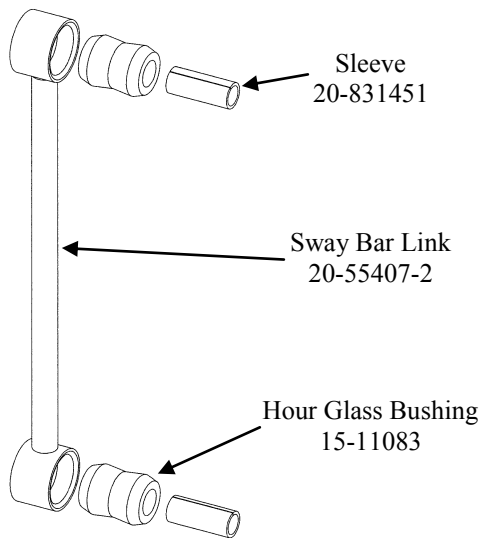
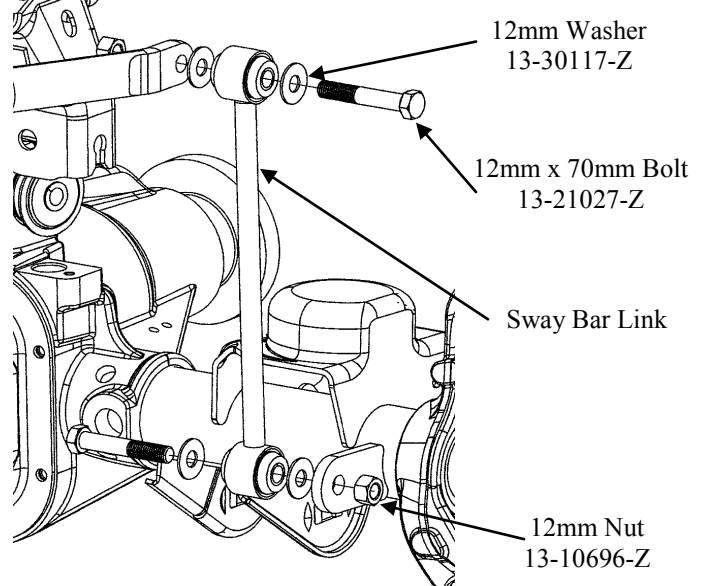
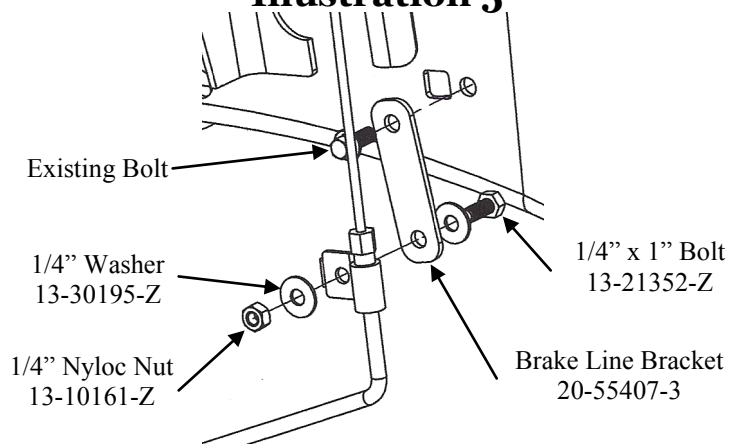

Illustration 4



5. Install new Front Coil Spring Spacers (15-12266) on top of springs retaining original spring pad.
6. Raise Axle and Install Front Shocks (24-146708). Torque lower bolt to 56 lb/ft. and upper stud until bushing just starts to compress.
7. Assemble Front Sway Bar Links as shown. (Illustration 3)
8. Install Sway Bar Links with hardware supplied. (Illustration 4) Torque bolts to 75 lb/ft.
9. Install Brake Line Drop Brackets as shown using hardware provided. (Illustration 5)
10. Install the wheels and tires, and lower the vehicle to the ground. Torque lug nuts to 115 lb/ft.

Illustration 5



Rear Installation Instructions

1. Raise the vehicle. If working without a shop hoist, support vehicle with suitable safety stands. To do this put vehicle in gear, block front wheels, both in front and behind tires, then disengage emergency brake. Place floor jack underneath rear axle and raise vehicle. Place safety jack stands under frame to support vehicle and lower vehicle onto safety stands. Remove rear tire/wheel assemblies.

2. Using a suitable floor jack, raise the jack just enough to support the rear axle's weight. Disconnect the sway bar end links. (Illustration 6)

3. Remove bolts attaching Brake Lines to frame. Disconnect ABS wire clips.

4. Remove Rear Shocks and then lower Rear Axle until Springs are free from upper mount. Remove Springs.

5. Install new Rear Coil Spring Spacers (15-12279) retaining original spring isolator and raise rear axle until the springs are seated.

6. Install Rear Shocks (24-146715). Torque lower bolt to 56 lb/ft. and upper bolts to 37 lb/ft.

7. Install Rear Brake Line Drop Brackets as shown, using hardware provided. (Illustration 7)

8. Re-attach Sway Bar End Links.

9. Install rear tire/wheel assemblies and lower vehicle. Torque lug nuts to 115 lb/ft.

Illustration 6

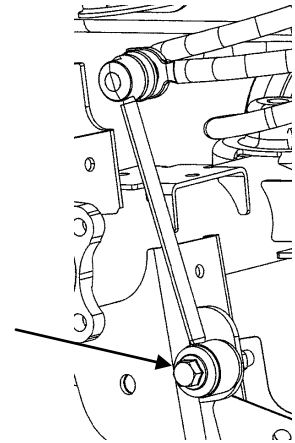
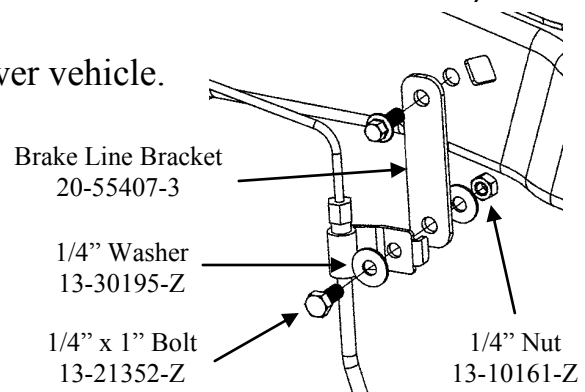

Illustration 7



Some Final Notes

- After installation is complete, double check that all nuts and bolts are tight. Refer to the torque specifications chart on the last page.
- If new tires are installed that are more than 10% taller than original tires, the speedometer must be recalibrated for the Anti-Lock Brake System to function properly. Contact an Authorized Jeep dealer for details on recalibration.
- With vehicle on the floor, cycle the steering lock to lock and inspect steering, suspension and driveline systems for proper operation, tightness and adequate clearance. Recheck brake/hose fitting for leaks. Be sure all hoses are long enough.
- Have headlights readjusted to proper setting.
- Realign front end to factory specifications. Be sure vehicle is at desired ride height prior to realignment.

Torque Specifications

General Torque Specifications:

5/16"	20 ft. lbs.
3/8"	35 ft. lbs.
7/16"	60 ft. lbs.
1/2"	90 ft. lbs.
9/16"	160 ft. lbs.
5/8"	175 ft. lbs.
3/4"	250 ft. lbs.

M6	9 ft. lbs.
M8	23 ft. lbs.
M10	45 ft. lbs.
M12	75 ft. lbs.
M14	120 ft. lbs.
M16	165 ft. lbs.
M18	220 ft. lbs.