



02/13/08

**'08-UP FORD SUPER DUTY 4WD  
4" SUSPENSION SYSTEM  
P/N: 10-42408**

**INSTALLATION INSTRUCTIONS**

**NOTE:** Each lift kit, and options to lift kits, are packaged separately. Therefore installation procedures are covered in separate instructions. Familiarize yourself with each specific set of instructions before beginning.

## **Part List**

<b><u>Item</u></b>	<b><u>Description</u></b>	<b><u>Qty.</u></b>	<b><u>Illus.</u></b>
<b>Box 1 of 4</b>			
20-52405-1	Radius Arm Drop, Drvr	1	5
20-52405-2	Radius Arm Drop, Pass	1	
20-52408-3	Track Bar Drop	1	8
13-90490	Loctite #262 Retaining Compound	1	
<b>Box 2 of 4</b>			
20-20452-1	Coil, Ford 05-up Super Duty 4WD, 4"	2	10
<b>Box 3 of 4</b>			
20-833024-1D	Block, Rear 4" W/Arm 5/8" Hole	1	12
20-833024-2P	Block, Rear 4" W/Arm 5/8" Hole	1	12
50-083404	Pitman Arm, Ford Super Duty 05-up	1	9
20-52408-7	Steering Damper Bracket	1	12
13-90776	U-Bolt, 5/8" x 3.6" x 15" RND	4	12
20-71175	Hardware Pack: Sway Bar		
20-52408-4	Sway Bar End Link	2	11
20-832374	Sleeve, 5/8"OD x .036 x 1.47"	4	11
15-11083	Bushing, Hour Glass	4	11
20-70629	Hardware Pack: Radius Arm Drops		
13-23263-Z	Hex Bolt, 3/4" x 5-1/2" Gr. 8	4	5
13-22093-Z	Hex Bolt, 7/16" x 1-1/2" Gr. 8	4	5
13-30499-Z	Washer, 3/4" Flat HRDN	8	5
13-30304-Z	Washer, 7/16" Flat HRDN	8	5
13-10644-Z	Nut, 3/4" Top Lock	4	5
13-10384-Z	Nut, 7/16" Top Lock	4	5
20-70642	Hardware Pack: Front Bumpstop Extensions		
20-52405-5	Front Bumpstop Extension	2	9
13-23614-Z	Hex Bolt, 8mm x 90mm Gr. 10.9	2	9
13-30850-Z	Washer, 8mm Flat HRDN	2	9
20-70655	Hardware Pack: Front Brakeline Drops		
20-52405-6	Brake Line Drop Bracket	2	10
13-21157-Z	Hex Bolt, 5/16" x 3/4"	2	10
13-30187-Z	Washer, 5/16" Flat	2	10
20-65471	Hardware Pack: U-Bolts		
13-30369	Washer, 5/8" Flat HRDN, Plain	8	13
13-10488	Nut, 5/8" High, Plain	8	13
20-71201	Hardware Pack: Steering Damper Bracket		
13-21664-Z	Hex Bolt, 1/2" x 1-1/4"	1	12
13-10514-Z	Nut, 1/2" Top Lock	1	12
13-30382-Z	Washer, 1/2" Flat HRDN	2	12
<b>Box 4 of 4</b>			
50-BE5-C438-T0	Shock, Front	2	
50-BE5-6246-H5	Shock, Rear	2	

## **INTRODUCTION**

- Installation by a professional mechanic is recommended. Use of the appropriate tools, a Ford service manual, and a shop hoist can greatly reduce installation time.
- Prior to installation, carefully inspect the vehicle's steering and drive train systems, paying close attention to the tie-rod ends, rack & pinion unit, ball joints and wheel bearing preload. Also check steering-to-frame and suspension-to-frame attachment points for stress cracks. The overall vehicle must be in excellent working condition; repair or replace worn parts.
- Read instructions carefully and study illustrations before attempting installation. **RCD Suspension** is not responsible for damage, failure or injury resulting from improper installation or parts substitution of this kit.
- Check parts and hardware against the parts list to assure that your kit is complete. The parts and hardware supplied are of high-grade material and must not be replaced by inferior parts or failure may result. Do not begin installation if parts are missing.
- Separate parts according to the areas they will be used. Placing the hardware with brackets before you begin will save installation time.
- This kit is supplied as a bolt-on assembly. Do not weld anything to the components and do not weld the components to the vehicle.
- All components in this kit come with a protective coating. Do not plate (i.e. chrome, cadmium, zinc etc.) or otherwise alter the finish in any way. This could decrease the structural strength of the components.
- Secure and properly block vehicle prior to beginning installation.
- Always wear safety glasses when using power tools.
- Foot-Pound torque readings are listed on the Torque Specifications chart at the end of the instructions unless specifically stated in an instruction. **DO NOT USE AN IMPACT WRENCH TO TIGHTEN ANY OF THE BOLTS.**

## **PLEASE NOTE**

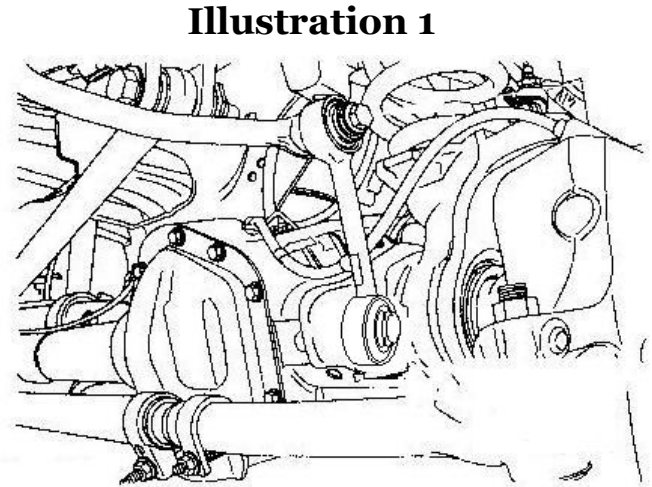
- **WARNING**: DO NOT USE WHEEL SPACERS
- Front-end realignment is necessary.
- Speedometer recalibration is necessary if larger tires (10% more than stock diameter) are installed.
- Vehicles equipped with a 2-piece rear drive shaft may require RCD (20-68747) drive shaft support drop down bracket kit.
- System is designed to accommodate up to a 35" x 12.5" tire on a minimum wheel size of 17" x 8" with a maximum of 4.75" backspacing.
- Special tools are required for safe removal and installation of the pitman arm, and tie-rods. These tools can be purchased from your Ford Dealer.

Pitman Arm Puller (P/N 211-003)

## **Front Installation Instructions**

1. Raise the vehicle. If working without a shop hoist, support vehicle with suitable safety jack stands. Put vehicle in gear, set emergency brake and block rear wheels, both in front and behind tires. Loosen front wheel lug nuts. Place floor jack under the front axle and raise vehicle. Place safety jack stands under frame rails, behind front wheel wells, and lower the frame onto the stands. Once securely on jack stands remove floor jack. Remove front wheels.

2. Using a suitable floor jack, raise the jack just enough to support the front axle's weight. Remove the sway bar end links. **(Illustration 1)**



3. Remove the bolts holding the brakelines to the frame at the top and the axle at the bottom.

4. Disconnect the Track Bar from the Track Bar Bracket. **(Illustration 2)**

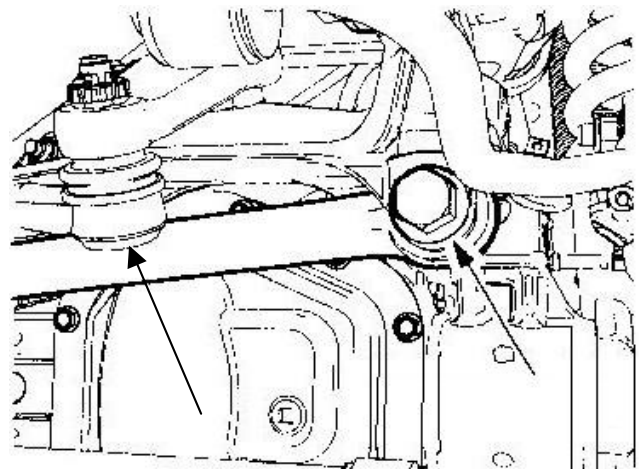
**Illustration 1**

5. Disconnect the Drag Link from the Pitman Arm. **(Illustration 2)**

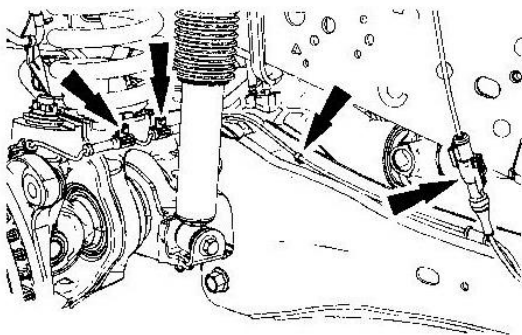
**Illustration 2**

6. Remove shocks and lower front axle till springs are loose. Remove springs.

7. Find the abs sensor wire connection at the back of the fender well just above the Radius Arm mount. Unclip wire from fender well. **(Illustration 3)**

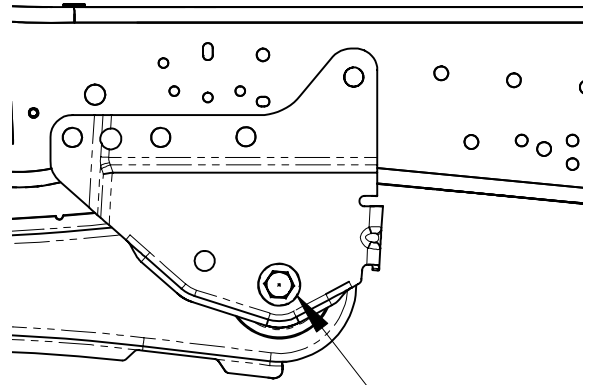


**Illustration 3**



## Illustration 4

- Remove the bolts holding the Radius Arms to the frame and lower radius arms out of frame. **(Illustration 4)**



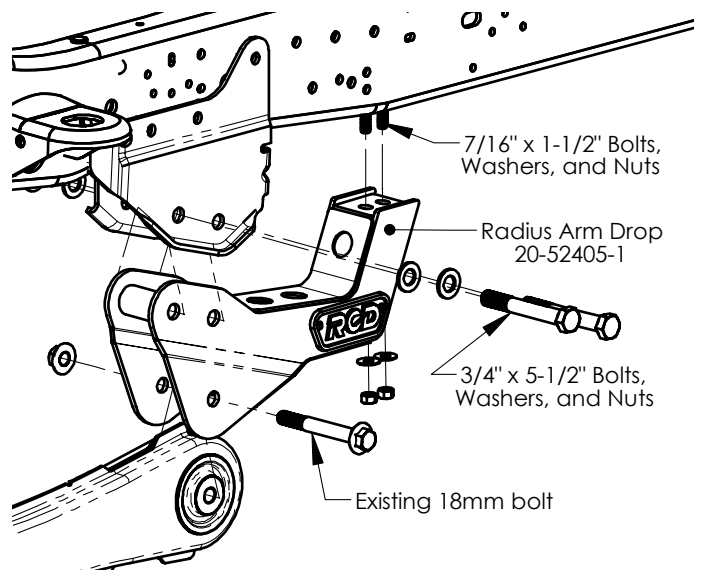
- Install RCD Radius Arm Drop Brackets 20-52405-1, 20-52405-2 to frame using two  $\frac{3}{4}$ " x 5-1/2" bolts, washers, and nuts, and two  $\frac{7}{16}$ " x 1-1/2" bolts, washers, and nuts. Torque the  $\frac{3}{4}$ " bolts to 250 lb. ft., and the  $\frac{7}{16}$ " bolts to 60 lb. ft. **(Illustration 5)**

- Raise Radius Arms into new brackets and install original bolts. **(Illustration 5)**  
**Do Not tighten at this time.**

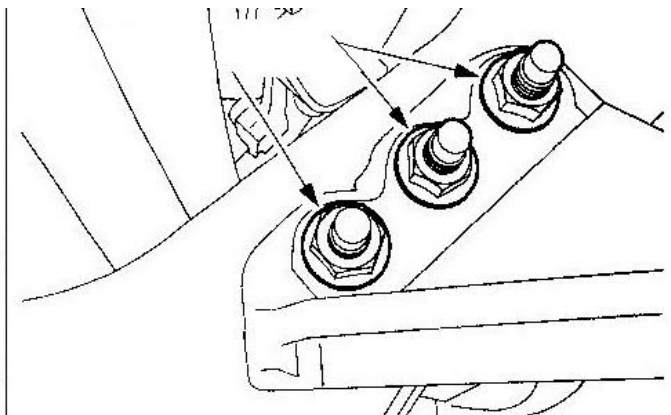
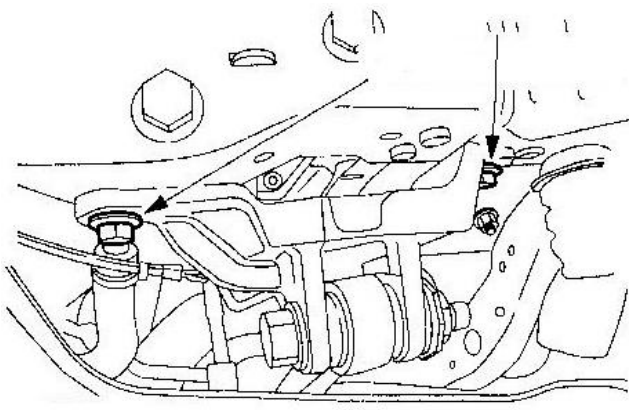
## Illustration 5

- On inner fender well measure down 4" from abs wire mounting holes and drill two new holes. Insert connector in these new holes.

- Remove Track Bar Bracket. **(Illustration 6)**

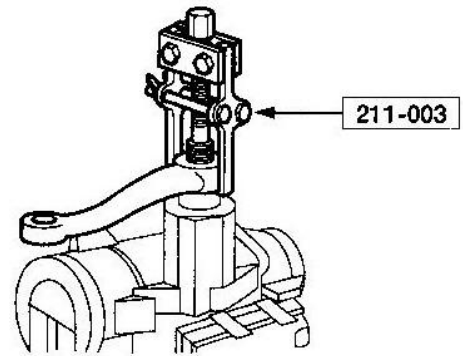


## Illustration 6



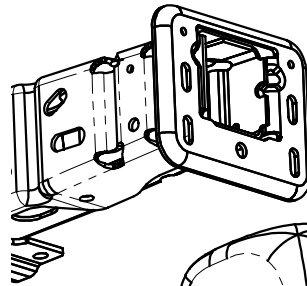
## Illustration 7

13. Remove Pitman Arm using special tool 211-003.  
**(Illustration 7)**



14. Install new Pitman Arm. Torque nut to 350 lb. ft.  
**Note: Clean threads thoroughly then apply locktite.**

15. Install RCD Track Bar Drop 20-52408-3 using original hardware.  
Torque to 129 lb. ft.  
**(Illustration 8)**

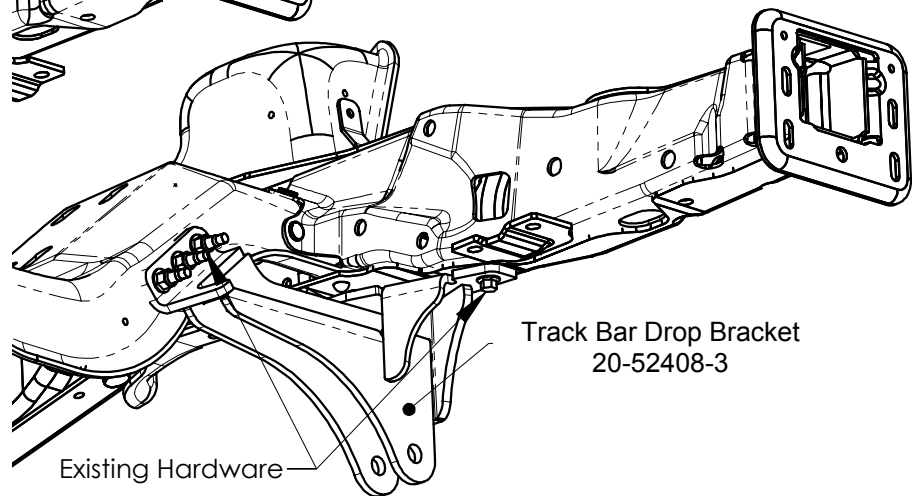


## Illustration 8

16. Attach Track Bar to Track Bar Drop using original hardware.  
Torque to 406 lb. ft.

17. Attach drag link to pitman arm. Torque to 148 lb. ft.

18. Install RCD Springs 20-20452-1, using original rubber isolator at top, making sure to align in seat at bottom.



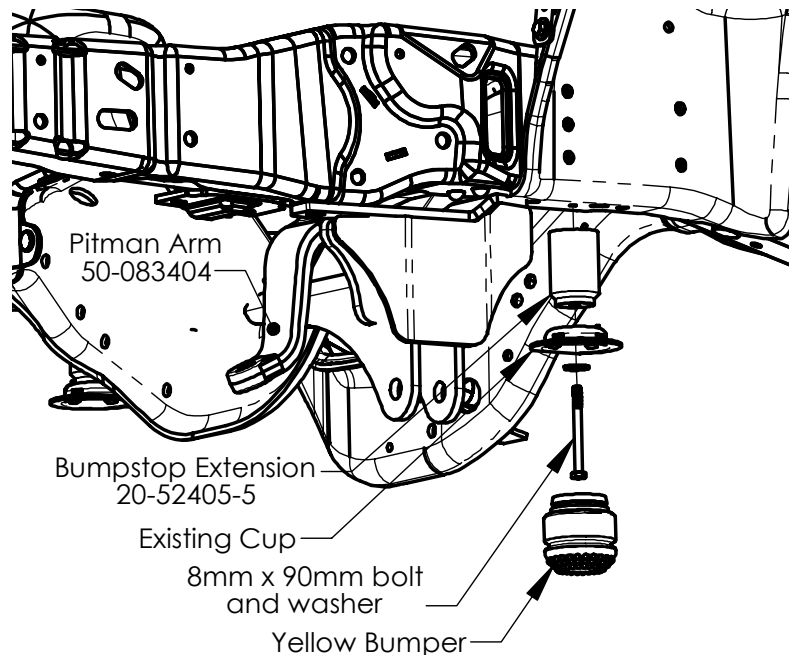
## Illustration 9

19. Pry yellow bumpstop out of bracket and remove bolt, holding cup to frame.

20. Install RCD Bumpstop Extension 20-52405-5 between cup and frame using 8mm x 90mm bolt and washer. Torque to 23 lb. ft. Reinstall yellow bumpstop in cup.  
**(Illustration 9)**

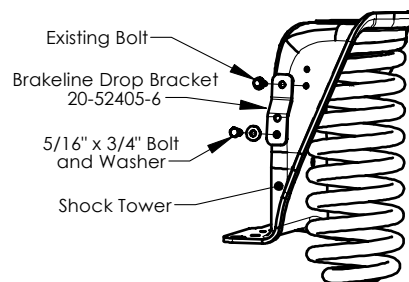
21. Raise front axle and install new shocks. Torque lower bolt to 111 lb. ft, and upper nut to 46 lb. ft.

22. Install RCD Brakeline Drop Brackets 20-52405-6 using original bolt at frame, and 5/16" x 3/4" bolt and washer to attach



brakeline to new bracket. Reattach brakeline to front axle at base of spring. **(Illustration 10)**

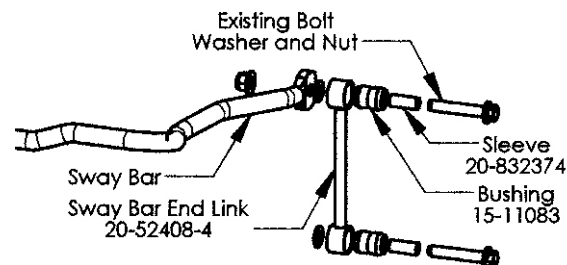
**Illustration 10**



23. Press Hour Glass Bushings (15-11083) into ends of both RCD Sway Bar End Links 20-52408-4. Press Sleeve (20-832374) into center of hourglass bushings. Install new Sway Bar Links into original position on vehicle using existing hardware. Torque upper and lower bolt to 111 lb. ft. **(Illustration 11)**

**Note: Be sure washer goes between sway bar and link.**

**Illustration 11**



24. Install the supplied Bilstein Front Shock Absorbers using the original bolt at bottom and the supplied nut, washer, and bushings on the upper shock mount. Torque lower bolt to 111 lb. ft. and upper nut until bushing is compressed.

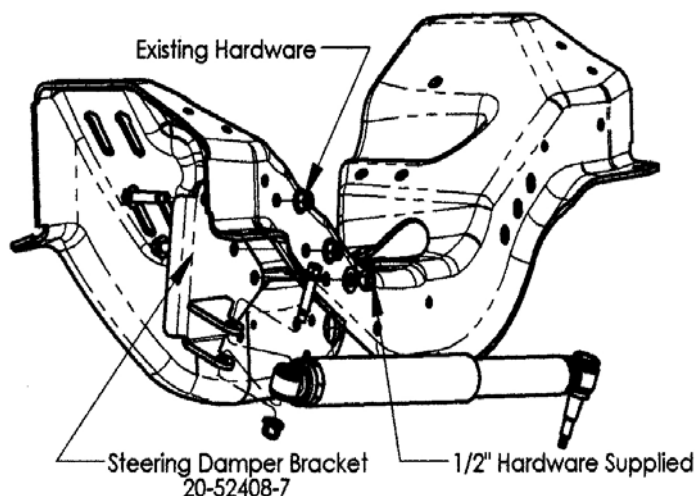
25. Remove original steering damper bracket and install the RCD 20-52408-7 Steering Damper Bracket with original hardware and 1/2" hardware supplied. **(Illustration 12)**

26. Install the wheels and tires, and lower vehicle to the ground. Torque lug nuts to 165 lb. ft.

27. Torque the Radius Arm bolts to 222 lb. ft.

28. **Recheck ALL hardware used to install complete suspension system at this time. Anything not tightened to the specified torque needs to be tightened now. Refer to chart on the last page of these instructions for general and specified torque values.**

**Illustration 12**





## **Rear Installation Instructions**

1. Raise the vehicle. If working without a shop hoist, support vehicle with suitable safety stands. Put vehicle in gear, block front wheels, both in front and behind tires, then disengage emergency brake. Place floor jack underneath rear axle and raise vehicle. Place suitable safety stands under frame to support vehicle and lower vehicle onto safety stands.
2. Remove rear tire/wheel assemblies.
3. Using suitable floor jack, raise rear axle enough to relieve tension on the shock absorbers and remove them.
4. With axle properly supported, remove rear spring U-bolts attaching rear axle to driver side leaf spring. Remove spring plate and existing rise block. Carefully lower rear axle.

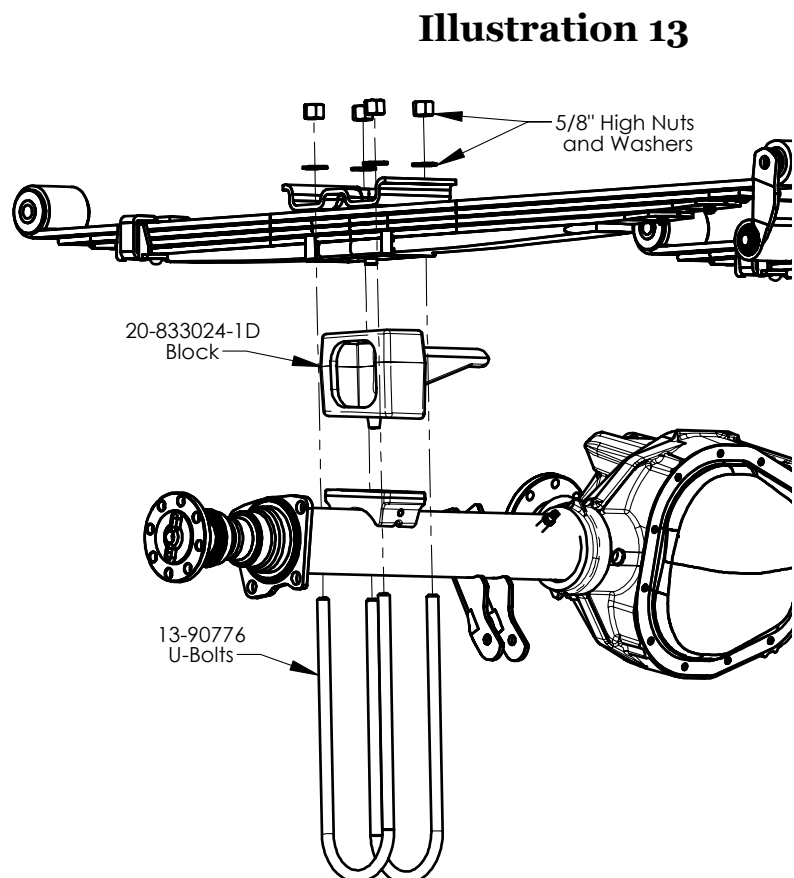
**CAUTION:** Do not allow axle to hang by any hoses or cables.

5. Insert new riser Block (20-833024-1D Drvr., 20-833024-2P Pass) on axle pad (**Illustration 13**). Make sure the locator pin in the block indexes into the hole of the axle housing spring pad. Carefully raise rear axle until block makes contact with leaf spring. Make sure center bolt is aligned with hole in block.

**Note:** If installing Trac-Link system, refer to separate instructions.

6. Re-mount axle to spring using the existing spring upper plate with new 5/8" U-Bolts (13-90776), Washers, and Nuts. Torque nuts to 99 ft. lbs. Tighten U-bolts evenly in a criss-cross sequence.

7. Repeat steps 4 through 6 on opposite side.



8. Install new longer Shock Absorbers (BE5-6246). Use the existing hardware to attach shock to the lower axle mount. Torque nuts to 35 ft. lbs. Attach shock to upper frame mount and torque nuts to 46 ft. lbs.
9. Install rear tire/wheel assemblies and lower the vehicle.

### **Some Final Notes**

After installation is complete, double check that all nuts and bolts are tight. Refer to the torque specifications chart on the last page.

If new tires are installed that are more than 10% taller than original tires, the speedometer must be recalibrated for the Anti-Lock Brake System to function properly. Contact an Authorized Ford dealer for details on recalibration.

With vehicle on the floor, cycle the steering lock to lock and inspect steering, suspension and driveline systems for proper operation, tightness and adequate clearance. Recheck brake/hose fitting for leaks. Be sure all hoses are long enough.

Have headlights readjusted to proper setting.

Realign front end to factory specifications. Be sure vehicle is at desired ride height prior to realignment.

## Torque Specifications

### General Torque Specifications:

<b>5/16"</b>	<b>20 ft. lbs.</b>
<b>3/8"</b>	<b>35 ft. lbs.</b>
<b>7/16"</b>	<b>60 ft. lbs.</b>
<b>1/2"</b>	<b>90 ft. lbs.</b>
<b>9/16"</b>	<b>160 ft. lbs.</b>
<b>5/8"</b>	<b>175 ft. lbs.</b>
<b>3/4"</b>	<b>250 ft. lbs.</b>

<b>M6</b>	<b>9 ft. lbs.</b>
<b>M8</b>	<b>23 ft. lbs.</b>
<b>M10</b>	<b>45 ft. lbs.</b>
<b>M12</b>	<b>75 ft. lbs.</b>
<b>M14</b>	<b>120 ft. lbs.</b>
<b>M16</b>	<b>165 ft. lbs.</b>
<b>M18</b>	<b>220 ft. lbs.</b>

### Existing Hardware Torque Specifications:

Track bar bracket-to-frame nuts and bolts	129 ft. lbs.
Track bar-to-track bar bracket bolt	406 ft. lbs.
Track bar-to-axle nut	185 ft. lbs.
Radius arm-to-bracket nut	222 ft. lbs.
Radius arm-to-axle bolts	222 ft. lbs.
Jounce bumper-to-frame nut	26 ft. lbs.
Stabilizer bar link-to-stabilizer bar nut	111 ft. lbs.
Stabilizer bar link-to-axle bolt	111 ft. lbs.
Front shock absorber-to-shock absorber bracket bolt	111 ft. lbs.
Front shock absorber-to-frame nut	46 ft. lbs.
Front brakeline-to-caliper banjo bolt	35 ft. lbs.
Hard Brakeline-to-Brake Hose Fitting	13 ft. lbs.
Pitman Arm-to-Steering Box Nut	350 ft. lbs.
Drag Link-to-Pitman Arm Nut	148 ft. lbs.
Rear Shock Absorber-to-Frame Bracket Nut	46 ft. lbs.
Rear Shock Absorber-to-axle Bracket Nut and Bolt	66.0 ft. lbs.
U-Bolt Nuts	100 ft. lbs.
Wheel Lug Nuts	165 ft. lbs.