

RBP-1109B-RX3



2001-2006 CHEVY SILVERADO 1500-3500 CREW CAB RX3

HARDWARE INCLUDED

- 12 8-1.25mm x 25mm Hex Bolts
- 12 8mm Lock Washers
- 18 8mm x 24mm OD x 2mm Flat Washers
- 6 8-1.25mm Hex Nuts
- 2 8-1.25mm Threaded Inserts
- 1 8mm Insert Tool

RECOMMENDED TOOLS

- 2 13mm Wrenches
- Drill with 7/16" bit

DRIVER-LEFT SIDE INSTALLATION:

STEP 1 – Remove any old steps, hardware, plastic plugs or insulation.

STEP 2– Locate the (4) tabs with holes, along the bottom edge of the driver side body panel, (**Figures 1—3**). **IMPORTANT:** Installation will use the 1st, 2nd and 4th mounting tabs only. Locate each threaded weld nut in the inner side of the body directly above the lower mounting tabs. **NOTE:** The rear mounting location does not have a factory threaded weld nut or mounting tab hole and requires drilling.

STEP 3 – With assistance, hold the Side Step up to the bottom of the body panel. Line up the attached brackets with the (3) mounting locations. Place a mark on the body panel for the upper rear mounting hole and a mark on the pinch weld for the lower rear mounting hole, (**Figure 4**). Use a 7/16" drill bit to drill out the (2) holes. **NOTE:** It is highly recommended to drill a small pilot hole for both the lower and upper mounting locations to ensure that the pinch weld hole is properly aligned with the bracket and threaded insert hole.

Step 4 – Assemble the metal Insert Tool as shown in **Figure 5**. Push the Tool and Insert assembly into the drilled hole. **NOTE:** If Metal Insert fits too tight, lightly tap it into place with a small hammer. Firmly hold the handle on the Tool and tighten the hex bolt in the Insert until it is fully locked in place. **NOTE:** Do not over tighten the Insert or a pull out may occur. Once Metal Insert is compressed, remove the hex bolt and tool from the Insert, (**Figure 6**).

Step 5 – Attach each Bracket to each upper threaded insert with (1) 8mm Hex Bolt, (1) 8mm Flat Washer, (1) 8mm Lock Washer and (1) 8mm Hex Nut, (**Figure 7**). Attach the lower tabs on the mounting brackets to the bottom of the body with (3) 8mm x 25mm Hex Bolts, (3) 8mm Lock Washers

RBP-1109B-RX3

and (3) 8mm STD Flat Washers, (Figure 8). **NOTE:** You may need to drill to enlarge the existing holes for the lower bracket. Snug but do not tighten hardware at this time.

STEP 7 - Once the Side Step is fully installed, verify the fitment and alignment. Fully tighten hardware.

STEP 8 - Repeat Steps 1—7 to install the passenger side RX3 Step assembly.

Periodically check installation and re-torque all fasters to specifications.

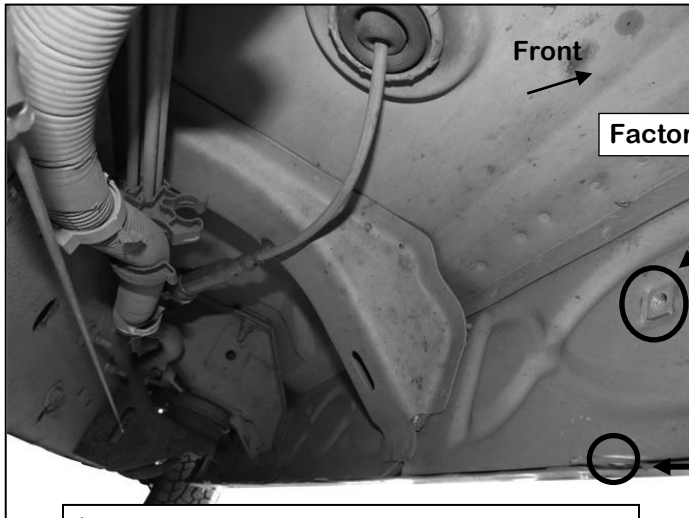

(Fig 1) Front driver/left installation location

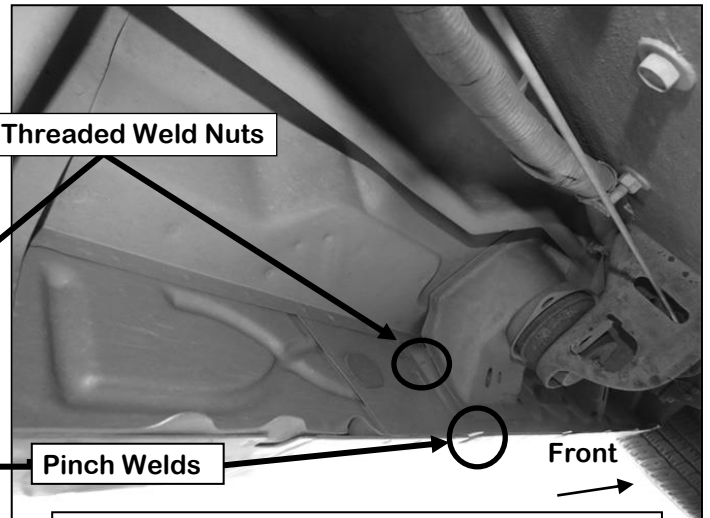

(Fig 2) Center driver/left installation location

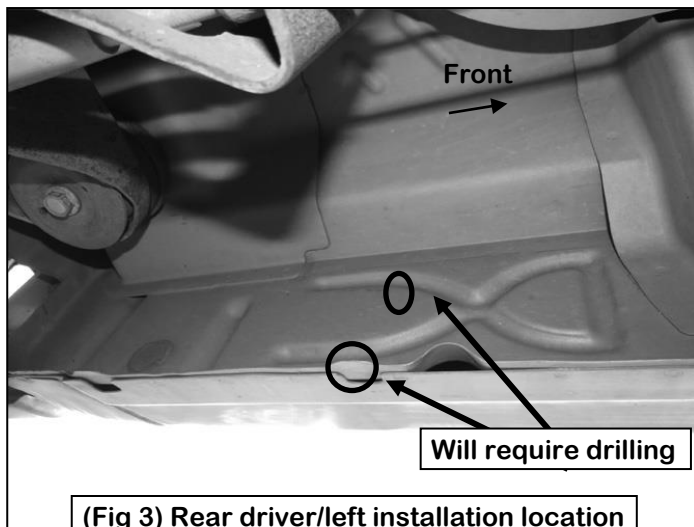

(Fig 3) Rear driver/left installation location

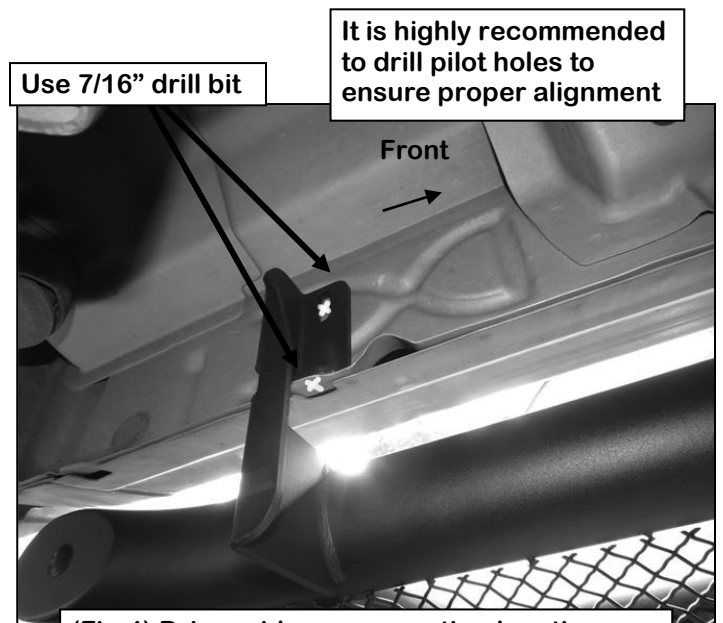

(Fig 4) Driver side rear mounting location marked for drilling illustrated as example only

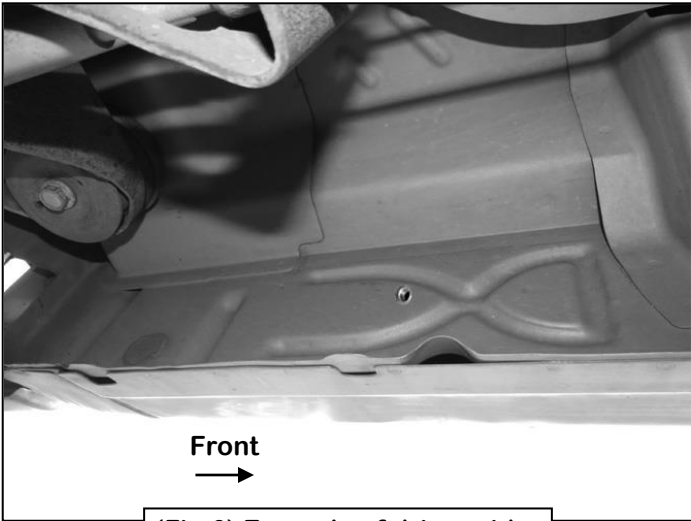
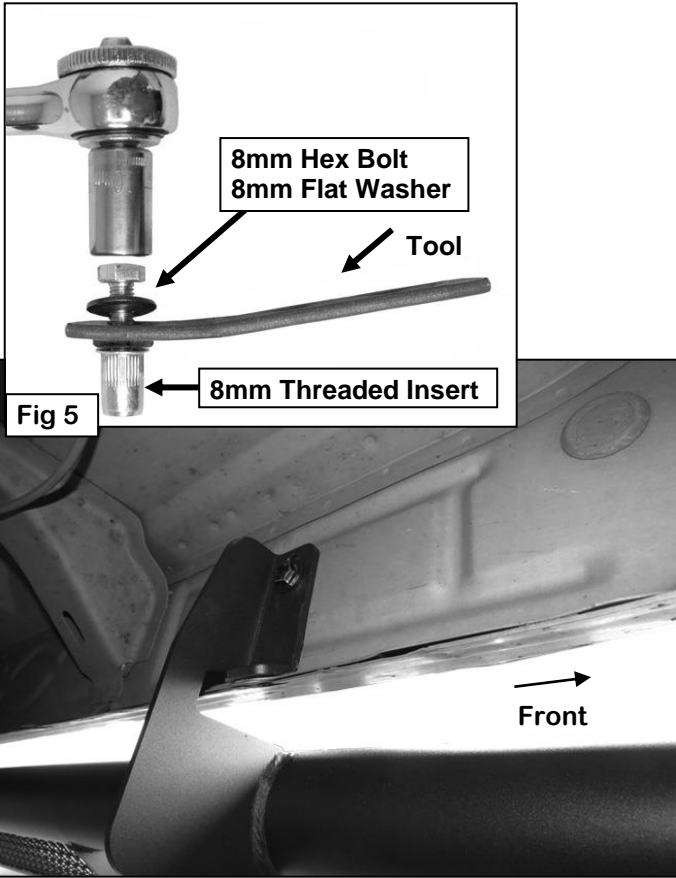

(Fig 6) Example of driver side rear threaded insert installed

(Fig 7) Driver side Center bracket installed

