

RBP-305B-RX7

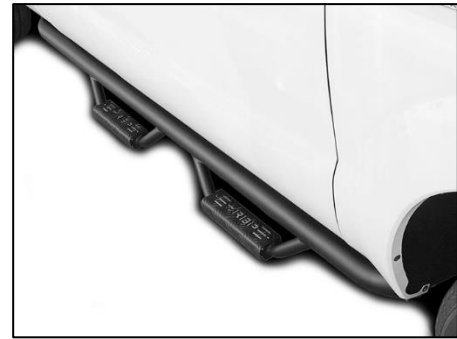

RBPTM

ROLLING BIG POWER



**1999-2016 FORD SUPER DUTY SUPER CAB 6.5FT STD
BED RX7 WHEEL TO WHEEL**

<u>HARDWARE INCLUDED</u>		<u>RECOMMENDED TOOLS</u>	
12	8-1.25 x 25mm Hex Bolt	2	13mm Wrenches
12	8mm Lock Washer	1	13mm Socket
18	8mm x 24mm OD x 2mm Flat Washer	1	3/8" Drive Ratchet
6	8mm Hex Nuts		
6	8mm U-Nuts		
2	12mm x 37mm OD x 3mm Spacers		

STEP1-Remove any old steps, hardware and any sealing tape and/or insulation that might be covering the holes in the inner panel, (Figure 1).

STEP 2-Start installation towards the front of the passenger/right side of the vehicle. Locate the front set of factory holes in the pinch weld under the front of the front door, (Figure 2). Next, locate the rectangular hole in the inner body panel, (Figure3). Insert (1) 8mm U-Nut into the rectangular opening and line up the threaded hole in the clip with the round hole next to the opening. **NOTE:** Threaded nut must go towards the inside of the body panel.

STEP 3-Move to the center mounting location. **NOTE:** There are (4) factory mounting locations along the cab, (Figure 1). Installation will use the rear set of mounting holes in the 1st, 3rd and 4th (last) mounting locations. Repeat step 2 to install the 8mm U-Nut in the center and rear mounting locations, (Figures 4 & 5). **IMPORTANT:** In the center and rear mounting locations, install the 8mm U-Nut in the rear mounting holes only. If necessary, hold the side step in position to determine correct mounting holes to use.

STEP 4-Select the passenger/right side step. With assistance, hold the side step in place and attach the top of the front bracket to the threaded U-Nut with (1) 8mm x 25mm Hex Bolt, (1) 8mm Lock Washer and (1) 8mm Flat Washer. **IMPORTANT:** Some models may have a gap between the bracket and the U-Nut in the body panel. Insert the included 12mm Flat Washer as a spacer between the body panel and the front bracket only, (Figure 6). Attach the bottom of the bracket to the pinch weld with (1) 8mm x 25mm Hex Bolt, (2) 8mm Flat Washers, (1) 8mm Lock Washer and (1) 8mm Hex Nut. **NOTE:** Insert Hex Bolts from the outside to inside, through the pinch weld and then the Bracket. Hand tighten hardware only at this time. Repeat this step to attach center and rear brackets, (Figure 7). **NOTE:** Spacer washer is only required on front bracket installation.

STEP 5-Once the step is installed and adjusted, fully tighten hardware to 20ft-lbs. Repeat previous steps for the driver/left side step installation.

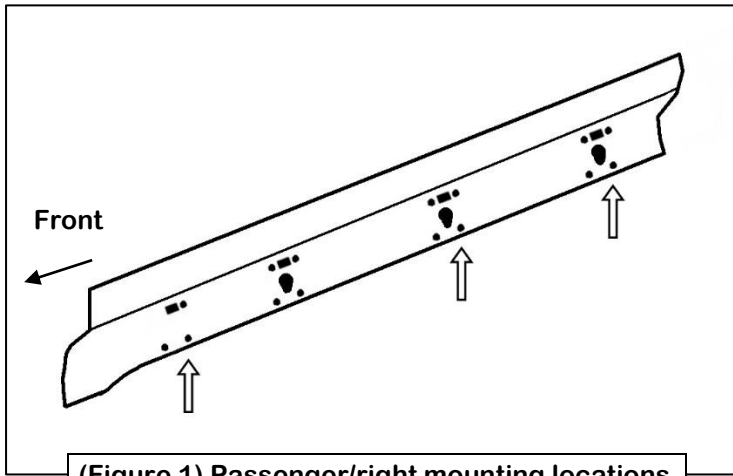

(Figure 1) Passenger/right mounting locations

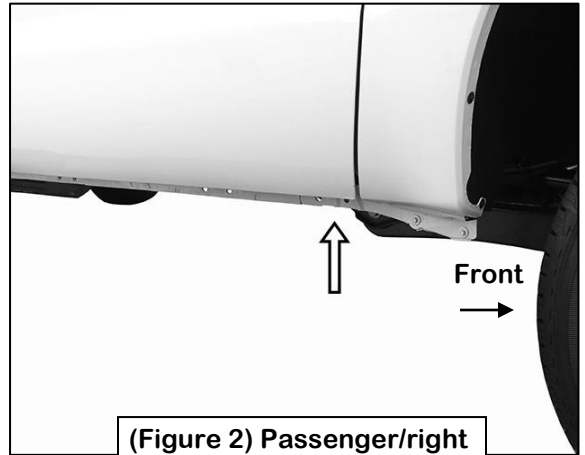

(Figure 2) Passenger/right front mounting location

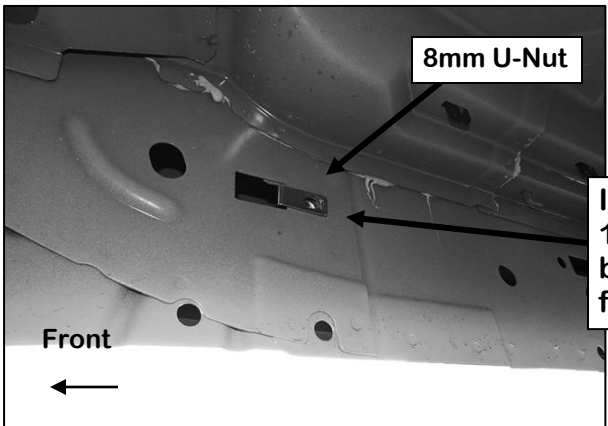

IMPORTANT: Insert the included 12mm Flat Washer as a spacer between the body panel and the front bracket only, (see Figure 6).

(Figure 3) Passenger/right front inner body panel

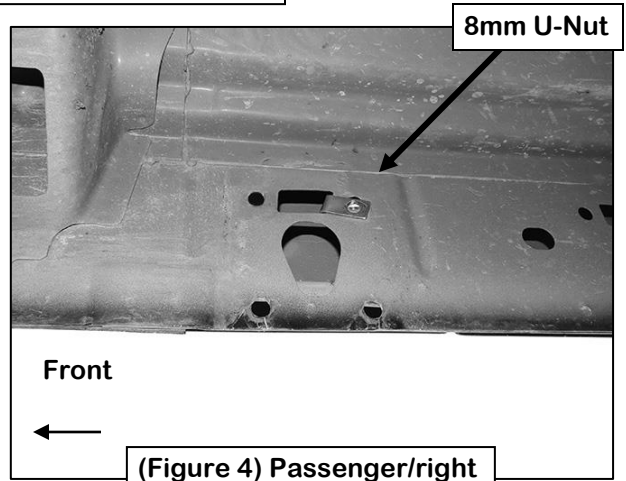

(Figure 4) Passenger/right center mounting location

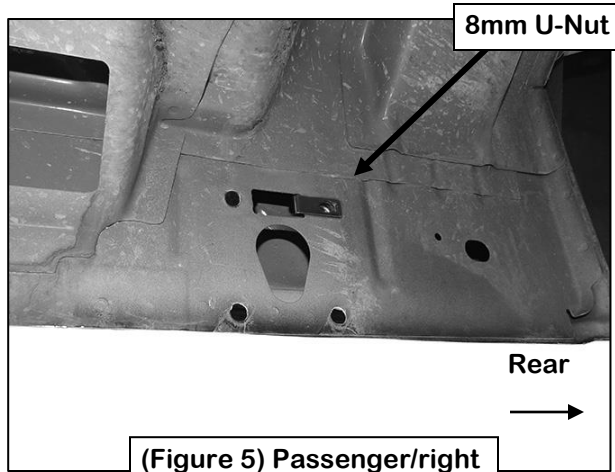

(Figure 5) Passenger/right rear mounting location

