

**RBP-1216B-RX3/RBP-1216SS-RX3**

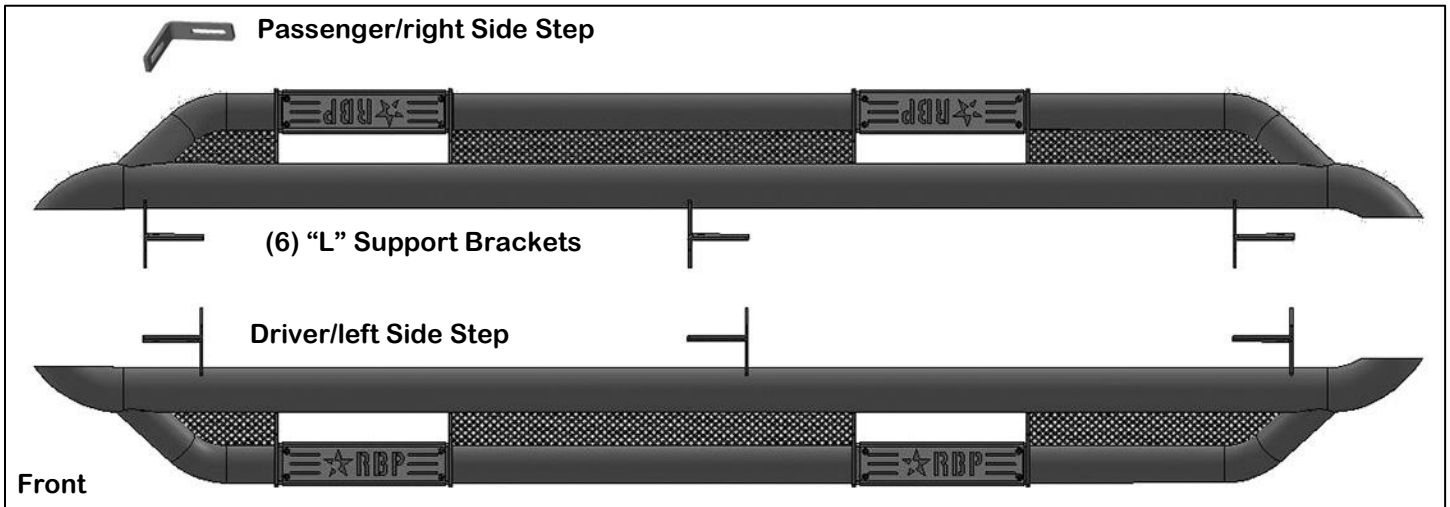

**2009-2017 DODGE RAM 1500, 2010-2017 2500 - 3500 CREW CAB RX3  
2006 - 2017 DODGE RAM 1500/2500/3500 MEGA CAB**



HARDWARE INCLUDED			
1	Driver Side RX-3 Side Step	24	8-1.25 x 35mm Hex Bolt
1	Passenger Side RX-3 Side Step	36	8mm x 24mm OD x 2mm STD Flat Washer
6	"L" Support Brackets	24	8mm Lock Washers
6	8mm Bolt/Nut Plates	12	8-1.25mm Hex Nuts
6	8mm Plastic Retainers	6	8-1.25mm Nylon Lock Nuts
RECOMMENDED TOOLS			
2	13mm Wrenches	1	3/8" Torque Wrench
	3/8" Ratchet with 3" and/or 6" Extension	1	Electric Drill
1	13mm Socket	1	3/8" Drill Bit

**STEP 1 - Remove any old steps and hardware from the truck.**

## ***RBP-1216B-RX3/RBP-1216SS-RX3***

**STEP 2** - Start installation towards the front of the passenger/right side of the vehicle. Locate the factory mounting holes in the side of the inner body panel, (Figures 1 & 2). NOTE: Remove any plugs or sealing tape as required, (Figure 2).

**STEP 3** - Determine the correct procedure for your vehicle. NOTE: Temporarily hold the Side Step assembly up in place to identify the correct mounting holes required for installation.

### **09-16 1500, 10-16 25-3500 without threaded inserts in any/all mounting locations:**

Locate the factory front mounting location along the inner body panel, (Figure 2). Partially thread an 8mm Hex Bolt into the threaded end of an 8mm Bolt and Nut Plate, (Figure 3). Thread the Hex Bolt in until it is flush with the welded nut, (Figure 4).

Use the Hex Bolt as a handle and insert the Bolt and Nut Plate into the oval hole, (Figure 5). Feed the threaded bolt on the Bolt Plate through one of the hex shaped factory holes.

Thread (1) 8mm Plastic Retainer onto the threaded end and down tight against the body panel, (Figure 6). NOTE: The Plastic Retainer is designed to keep the Bolt/Nut Plate from falling into the body panel and to aid in Bracket installation. Repeat this Step to install an 8mm Bolt/Nut Plate in any or all mounting locations.

With assistance, hold the driver side step assembly up in position over the Bolt/Nut Plates and against the mounting locations. Attach the brackets on the Step assembly to the (3) Bolt/Nut Plates with (3) 8mm Flat Washers, (3) 8mm Lock Washers and (3) 8mm Hex Nuts, (Figure 7). Do not tighten hardware.

Starting at the front location, remove the 8mm Hex Bolt from the nut on the Bolt Plate.

Rotate the Bolt on the Bolt Plate until the threaded nut lines up with the remaining hole in the Mounting Bracket and hex hole in the body panel, (Figure 7).

Attach the Bracket to the threaded Nut Plate with (1) 8mm Hex Bolt, (1) 8mm Lock Washer and (1) 8mm Flat Washer, (Figure 8). Do not fully tighten hardware at this time.

Repeat to attach the center and rear mounting brackets to the Bolt/Nut Plates.

### **09-on 1500, 10-16 25-3500 with threaded inserts in any/all mounting locations:**

Locate the factory mounting locations along the inner body panel, (Figures 1 & 9).

With assistance, hold the driver side step assembly up in position against the mounting locations.

Attach the brackets on the Step assembly to any factory threaded insert with 8mm Hex Bolt, 8mm Lock Washer and 8mm Flat Washer, (Figures 10 & 11). Do not tighten hardware. Repeat for any/all threaded inserts.

**STEP 5** - Determine the correct procedure to install the “L” Support Brackets for your vehicle.

### **09-12 1500, 10-12 25-3500 without holes in pinch weld for Support Brackets:**

Select (1) “L” Support Bracket. Attach the support bracket to the back of the front bracket with (1) 8mm Hex Bolt, (2) 8mm Flat Washers, (1) 8mm Lock Washer and (1) 8mm Hex Nut. NOTE: Use the bottom hole in the mounting bracket, (Figure 10). Leave loose at this time.

Hold the Support Bracket up to the back of the pinch weld and tighten the hex bolt.

Use the support bracket for a template and mark the hole location onto the back of the pinch weld.

Move the support bracket out of the way.

Use a 3/8” drill bit to drill a hole through the pinch weld.

Attach the “L” Support Bracket to the pinch weld with (1) 8mm Hex Bolt, (2) 8mm Flat Washers and (1) 8mm Nylon Lock nut, (Figures 10 & 11). Leave hardware loose at this time.

Repeat to attach the center and rear support brackets to the pinch weld.

### **12-on models with factory holes in the pinch weld:**

Follow previous 09-12 instructions to attach “L” Support Bracket to Mounting Bracket.

Attach the bracket to the factory hole in the pinch weld with (1) 8mm Hex Bolt, (2) 8mm Flat Washers and (1) 8mm Nylon Lock nut, (Figures 10 & 11). Leave hardware loose at this time.

# RBP-1216B-RX3/RBP-1216SS-RX3

Repeat to attach the center and rear “L” support brackets to the pinch weld.

**STEP 6 -** Align and adjust the step to the side of the vehicle. Once properly adjusted, tighten all hardware. Tighten the 8mm hardware to 18-20ft-lbs.

**STEP 7 -** Repeat the above steps for the driver/left side installation.

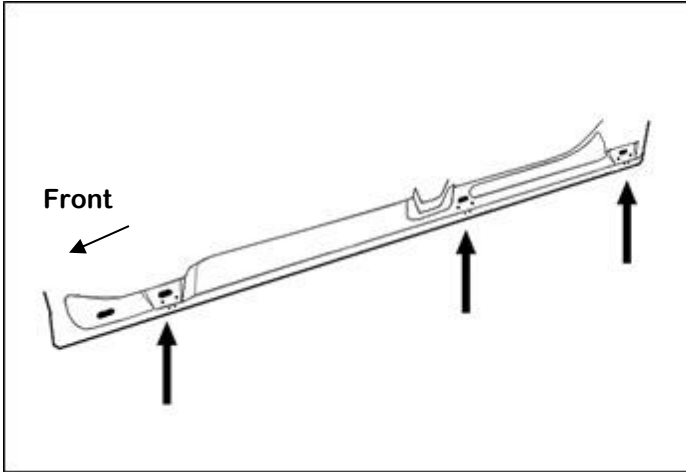

(Fig 1) 09-on passenger/right mounting locations

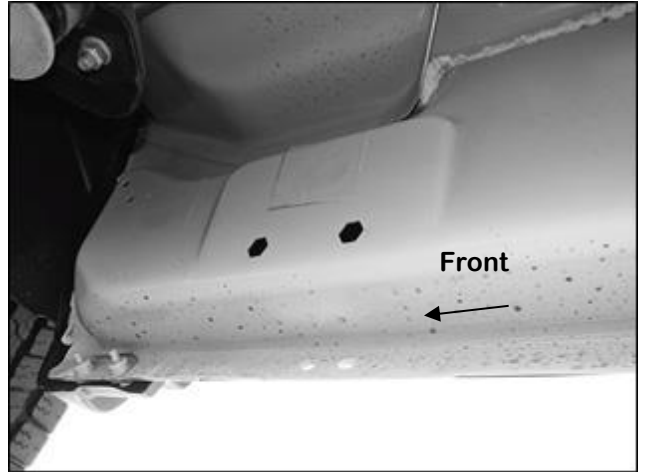

(Fig 2) 09-on passenger/front mounting location (not equipped with threaded inserts)

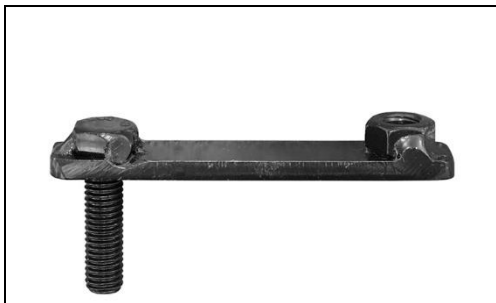

(Fig 3) 8mm Bolt-8mm Nut Plate, NOTE: 8mm Bolt-Nut Plate is not required on models with threaded inserts

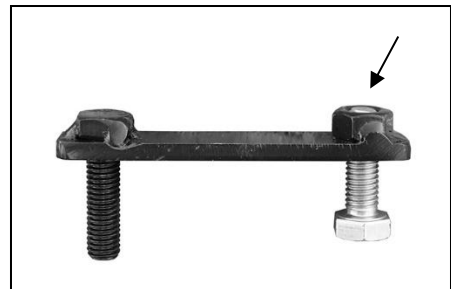

(Fig 4) Thread (1) 8mm Hex Bolt into the nut on the plate. Stop when bolt reaches end of nut as pictured

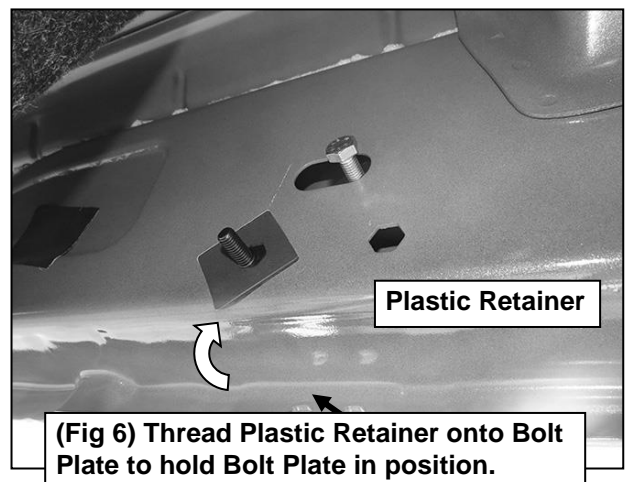
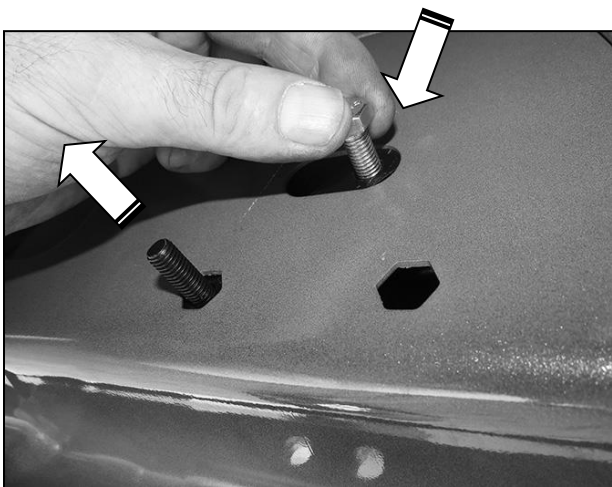

(Fig 6) Thread Plastic Retainer onto Bolt Plate to hold Bolt Plate in position.

# RBP-1216B-RX3/RBP-1216SS-RX3

(Fig 5) Use the loose Hex Bolt as a handle. Insert the Bolt Plate into the oval hole and feed the threaded end out either factory hex shaped hole. **IMPORTANT:** Do not let go of the hex bolt until after Plastic Retainer has been threaded onto bolt (Fig 5)

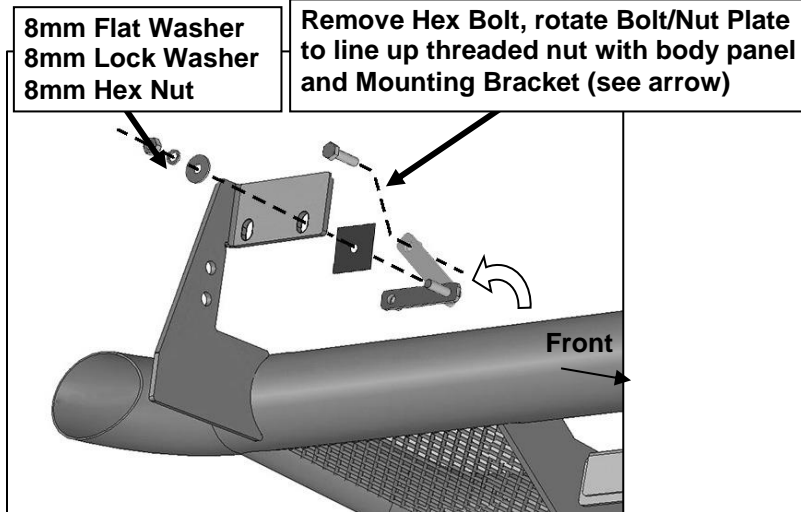

(Fig 7) Attach Bracket to Bolt Plate

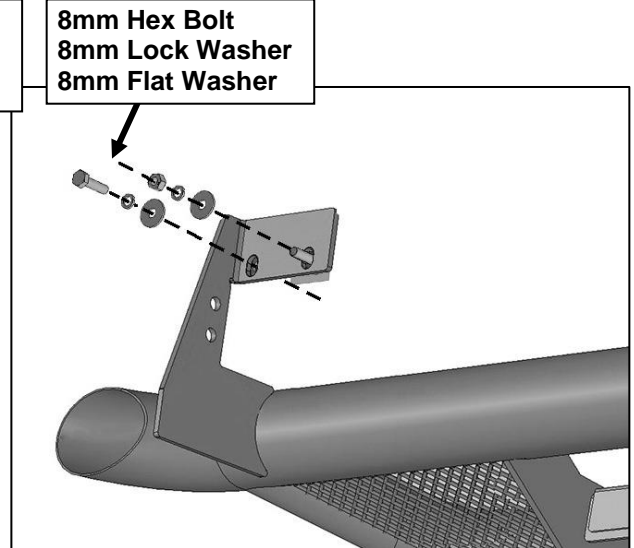

(Fig 8) Attach Bracket to threaded end of Bolt Plate first. Remove 8mm Hex Bolt (see Fig 3). Rotate Bolt Plate to line up with remaining factory hex shaped hole.

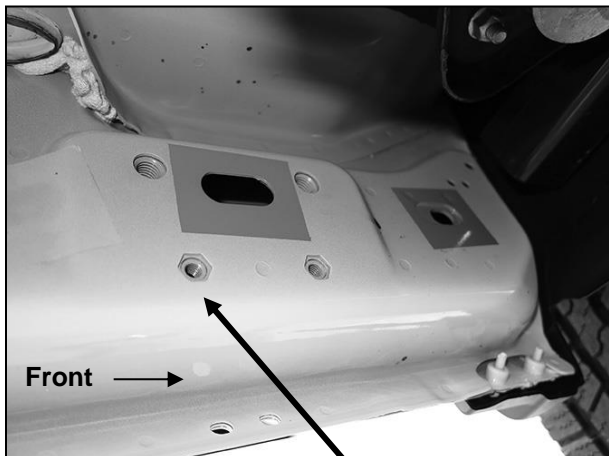

(Fig 9) Driver side front mid 2015-on, an example of models with factory installed threaded inserts

Models with threaded inserts  
(2) 8mm Hex Bolts  
(2) 8mm Lock Washers  
(2) 8mm Flat Washers

8mm Hex Bolt  
(2) 8mm Flat Washers  
8mm Nylon Lock Nut

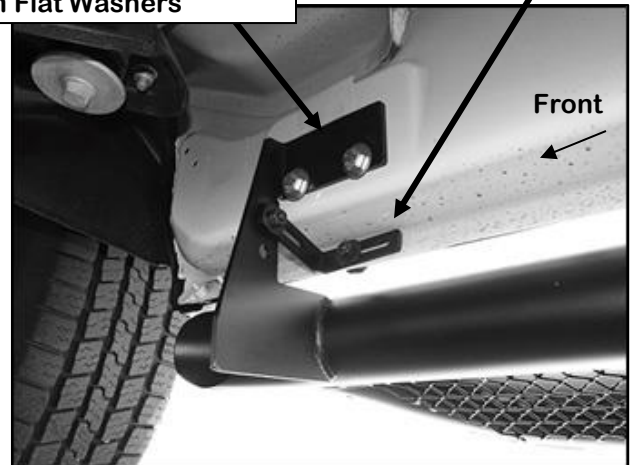

(Fig 10) 09-on passenger/right front bracket



(Fig 11) 09-on passenger/right center bracket