

5" OVAL BAR CURVED

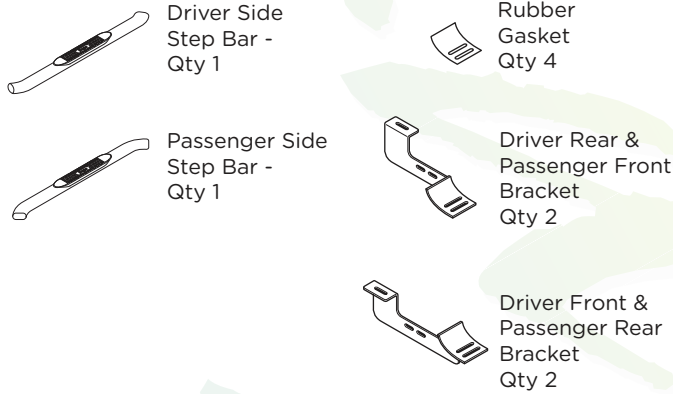

Components:



Hardware:

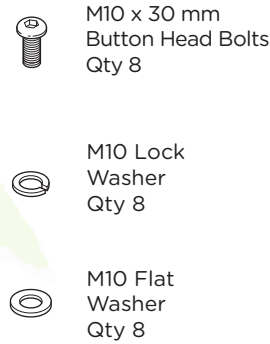

Tools Required:



Torque Specifications:

For Cab Mount Installations
 Cab mount bolts are torqued to 70 Ft Lbs. All other M8 through M12 sized bolts/nuts are set to 15-20 ft lbs.

Note: When installing the brackets and bars, all hardware must be left loose until all the items are attached.

1. Remove all contents from the package and check all tubes for any damage. Also, verify that all components and hardware listed above are included before you begin installation.
2. Read installation manual and installation drawing completely. Understand all brackets and bolts before installation.
3. Begin installation on the driver's side. Remove the existing Cab Mount Bolts. **DO NOT DISCARD!**

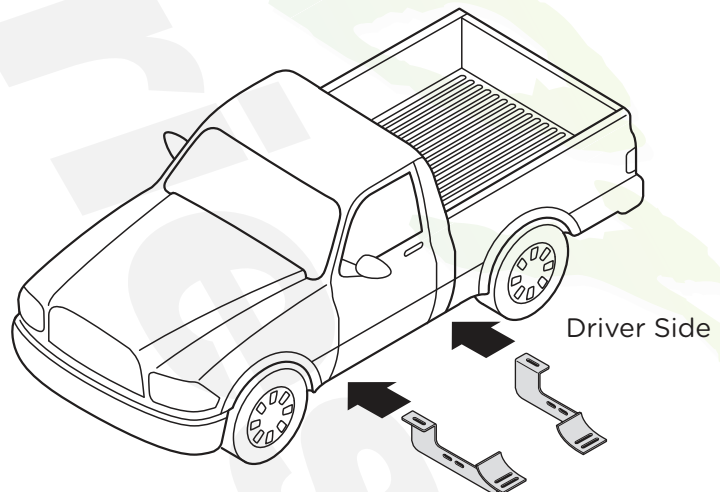

4. Install the Rear Mount Brackets by using the existing Cab Mount Bolts removed in step 3.

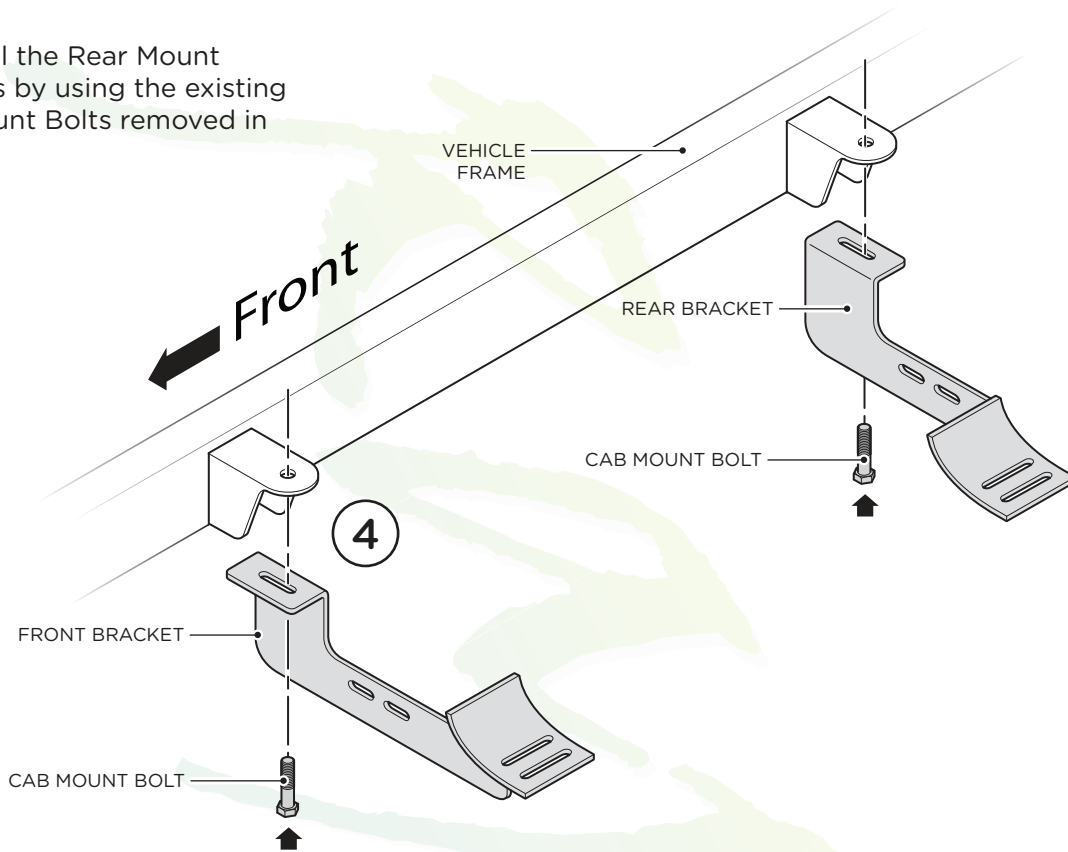

5. Place the Step Bar and the Rubber Gaskets onto the Brackets as shown (5). Each Step Bar is marked Driver and Passenger.

6. Secure the Step Bar to each Bracket using two (2) M10 x 30MM Button Head and two (2) M10 Lock Washers and two (2) M10 Flat Head Washers per bracket.

Tighten until the split lock washer is flat against bracket and snug. **DO NOT** over tighten and strip the threaded insert in the tube.

Repeat these steps for passenger side installation. When all hardware is in place, everything must be tightened. See Page 1 for Torque Specifications.

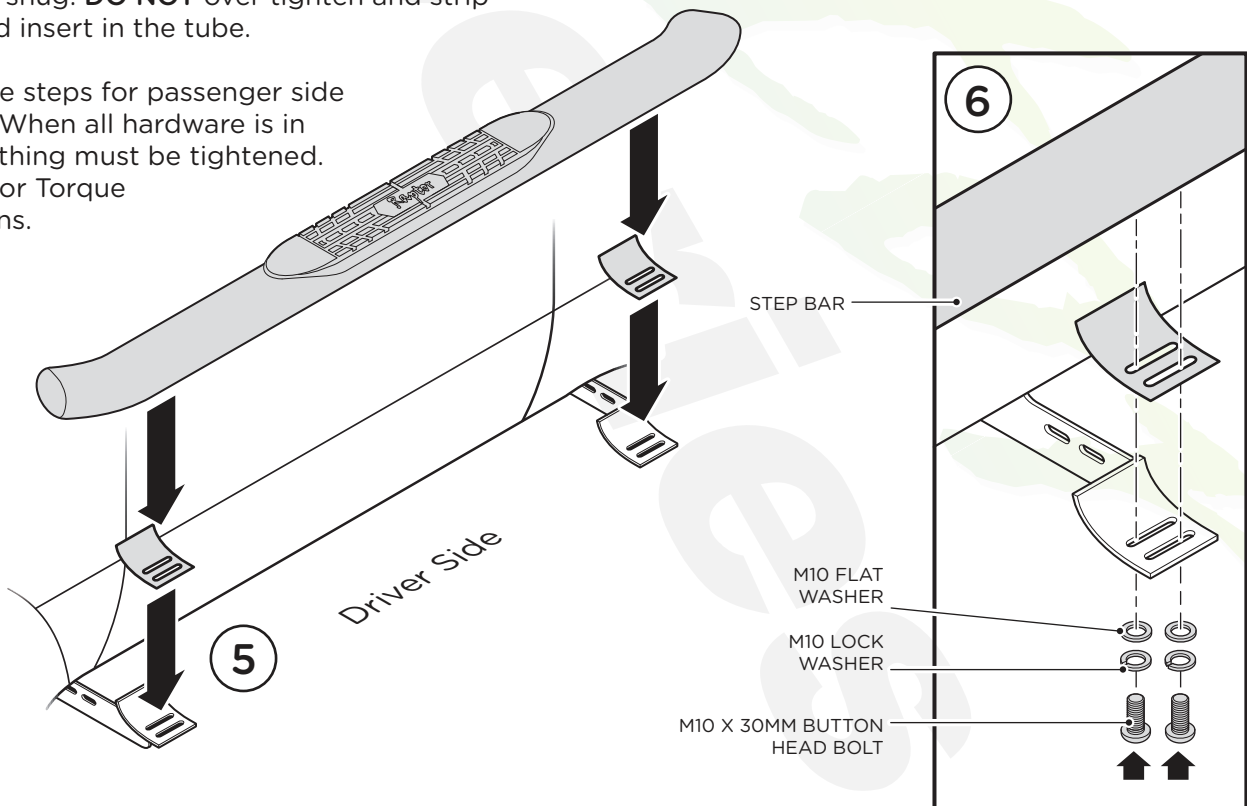

ADDENDUM

For 2014 Current Chevy/GMC Regular Cab 1500 Model

Raptor Series

Place **Spacer Washers** as shown in the diagram below.



DO NOT use pneumatic or electric impact on Cab Mount Bolts.

Front Bracket

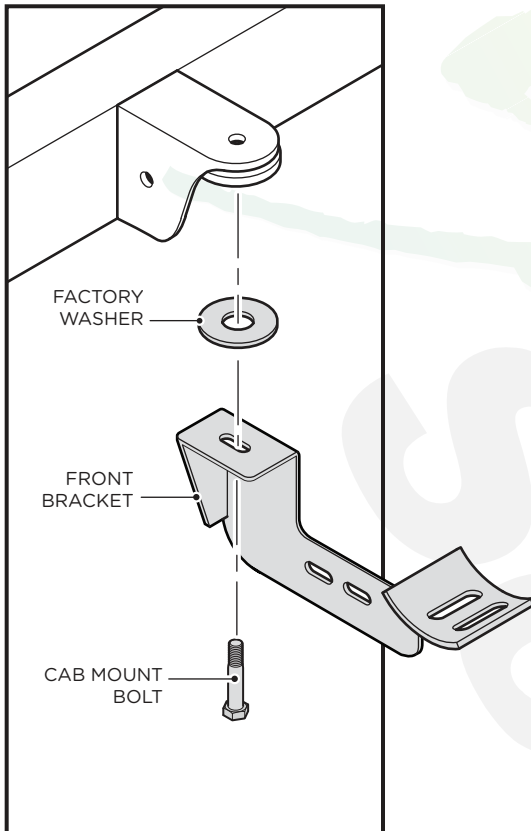

Rear Bracket

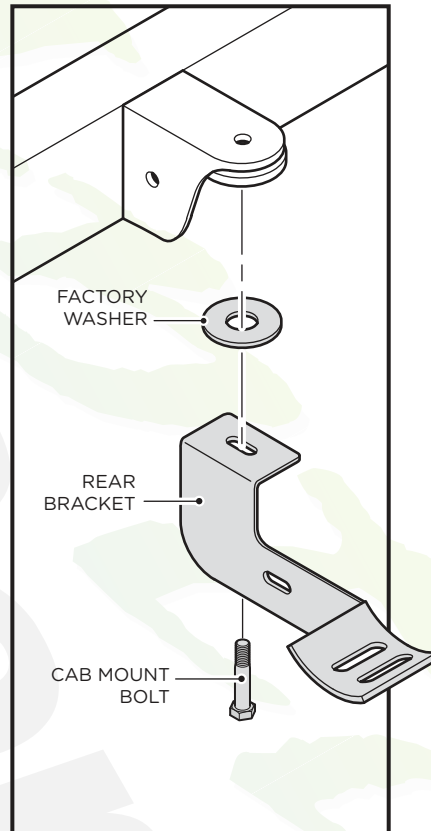

ADDENDUM

For 2015 Current Chevy/GMC Regular Cab 2500-3500 Model

Place **Spacer Washers** as shown in the diagram below.



DO NOT use pneumatic or electric impact on Cab Mount Bolts.

Front Bracket

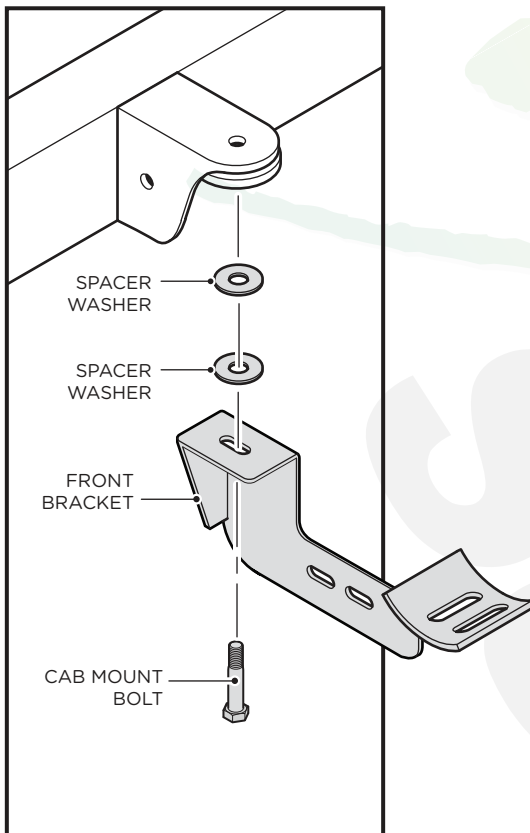

Rear Bracket

