

1505-0204, 1505-0204B

4" OVAL BAR CURVED

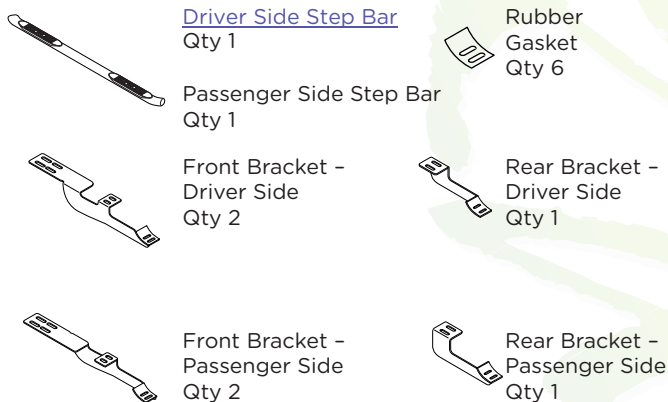

Components:



Hardware:



Tools Required:

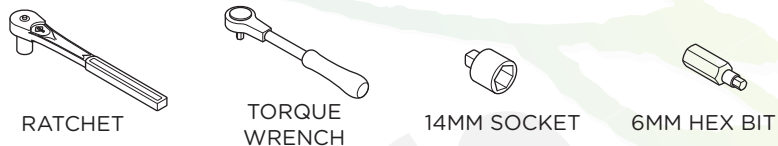

Torque Specifications:

For Frame Mount Installations
 Frame mount bolts are torqued to 70 Ft Lbs. All other M8 through M12 sized bolts/nuts are set to 15-20 ft lbs.

Note: When installing the brackets and bars, all hardware must be left loose until all the items are attached.

1. Remove all contents from the package and check stainless steel tubes for any damage. Also, verify that all components and hardware listed above are included before you begin installation.

2. Begin installation on driver's side of vehicle.

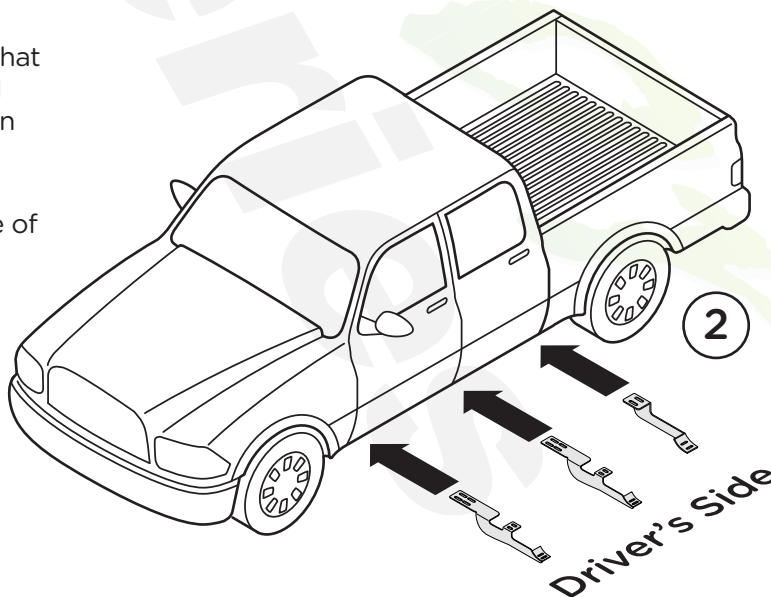

3. Both front and center brackets are the same for each side. The cradle on each bracket should hang over towards the rear of vehicle. Align driver's side Front, Center and Rear Brackets to underside of vehicle and align with holes as shown.

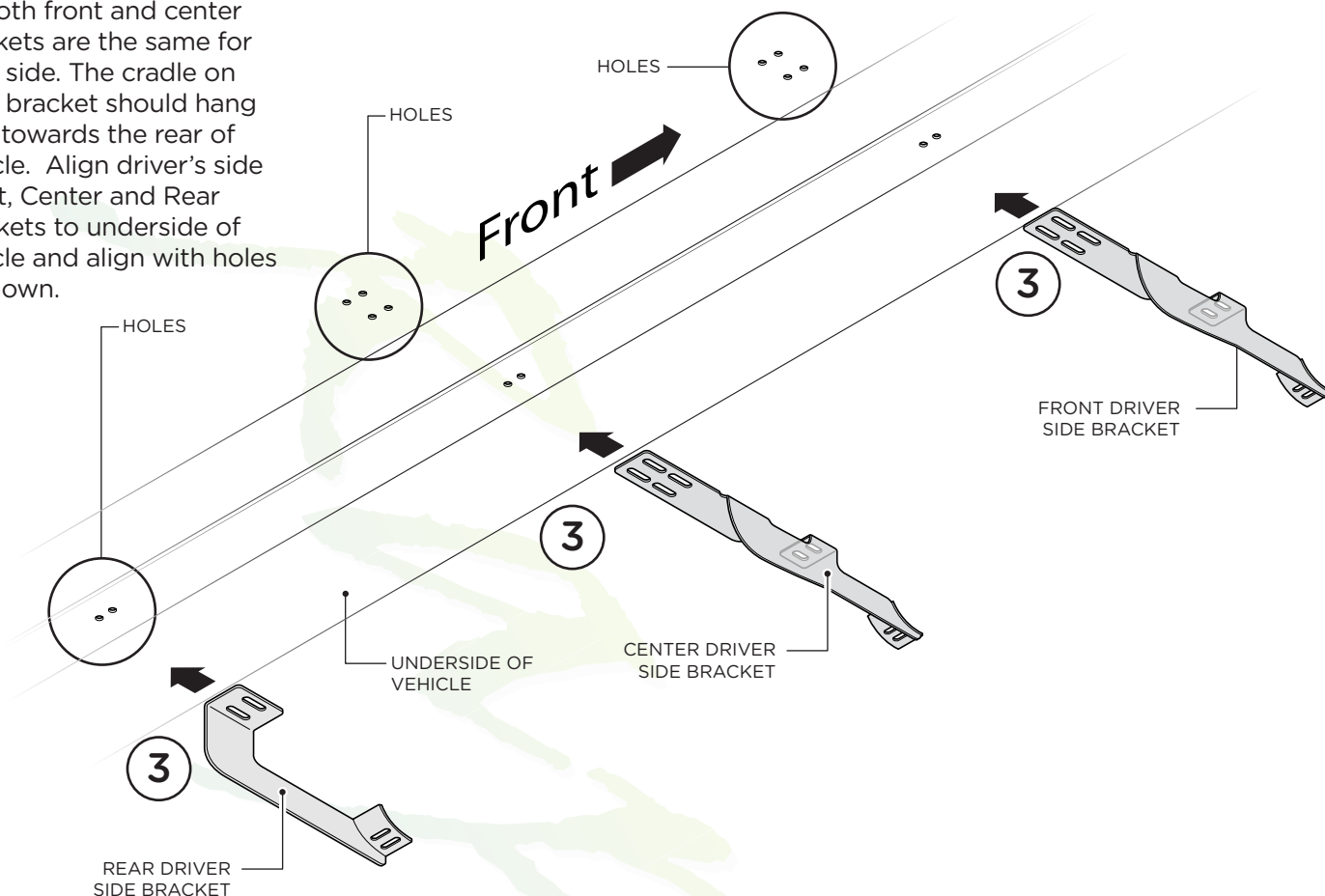

4. Fasten the Driver's side Front and Rear Brackets to the underside of the vehicle using two (2) M8 x 30MM Hex Head Bolts, two (2) M8 Lock Washers and two (2) M8 Flat Washers per bracket.

Hand tighten all hardware.

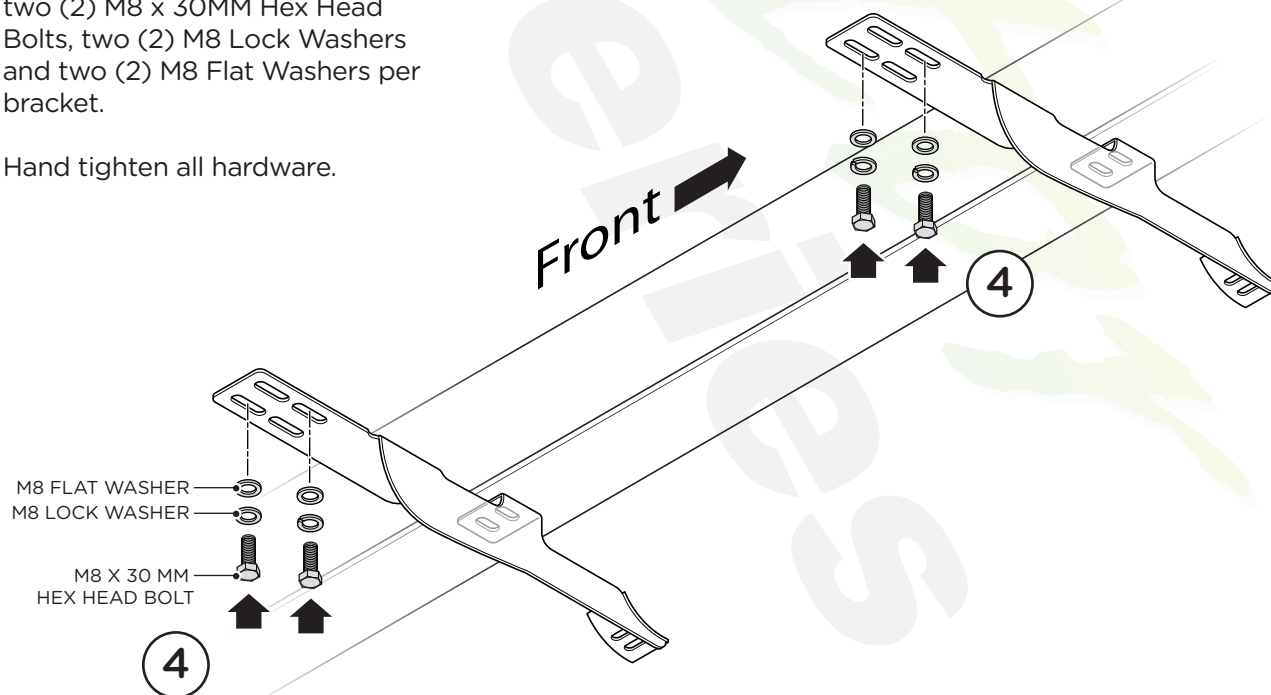

5. Fasten the other end of the Driver side Front and Rear Brackets to the underside of the vehicle using two (2) M8 x 30MM Hex Head Bolts, two (2) M8 Lock Washers and two (2) M8 Flat Washers per bracket.

Hand tighten all hardware.

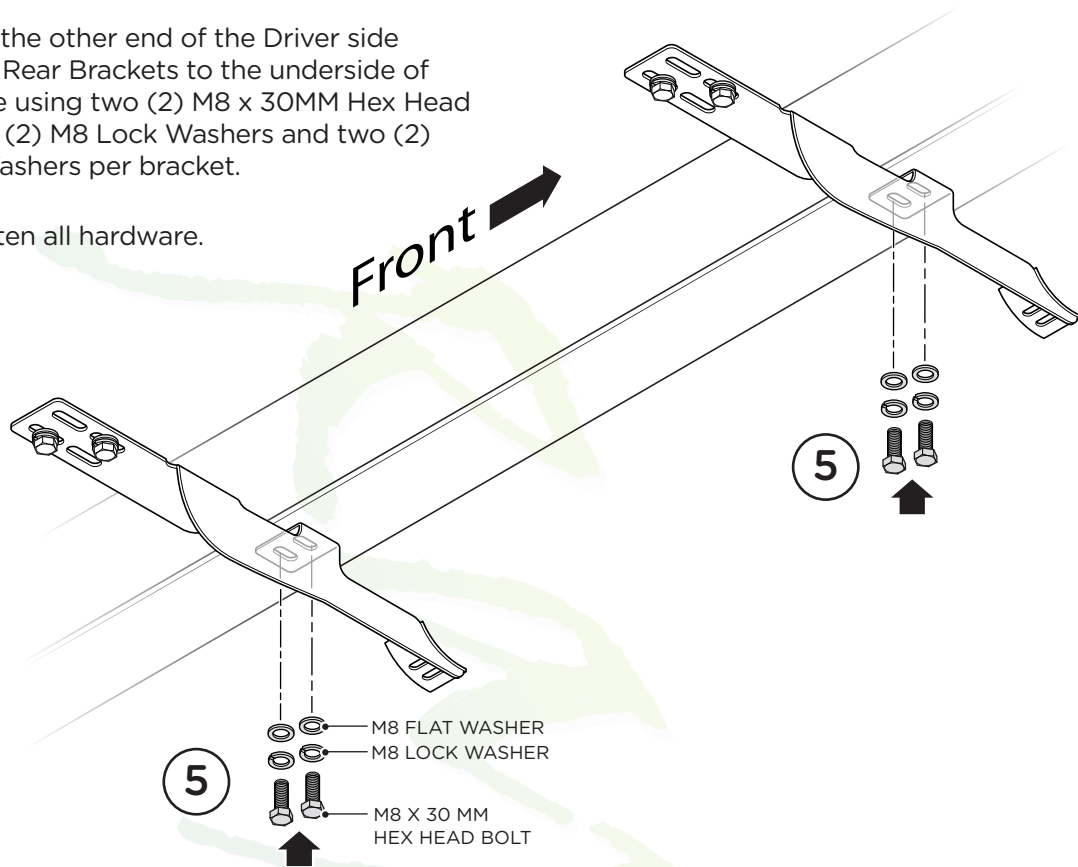

6. Fasten the Driver's side Rear Bracket to the underside of the vehicle using two (2) M8 x 30MM Hex Head Bolts, two (2) M8 Lock Washers and two (2) M8 Flat Washers per bracket.

Hand tighten all hardware.

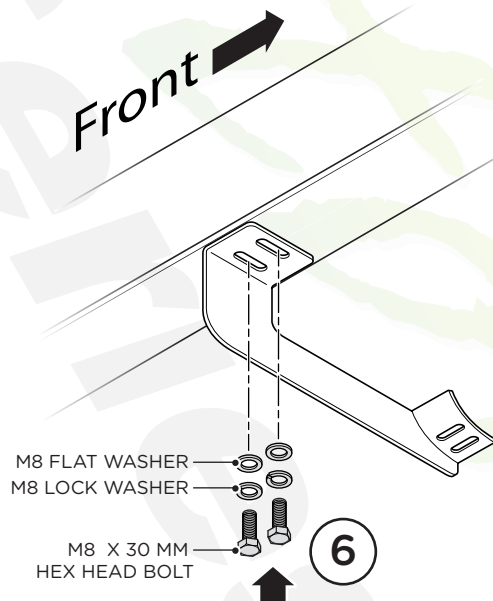

7. Place Step Bar and Rubber Gaskets onto Brackets. Each Step Bar is marked Driver and Passenger.

8. Attach the Step Bar to each Bracket using two (2) M10 Button Head Bolts, two (2) M10 Lock Washers and two (2) M10 Flat Washers per bracket.

Tighten until the split lock washer is flat against bracket and snug. **DO NOT** over tighten and strip the threaded insert in the tube.

Repeat these steps for passenger side installation. When all hardware is in place, everything must be tightened. See Page 1 for Torque Specifications.

