

1504-0247, 1504-0247B

4" OVAL BAR CURVED

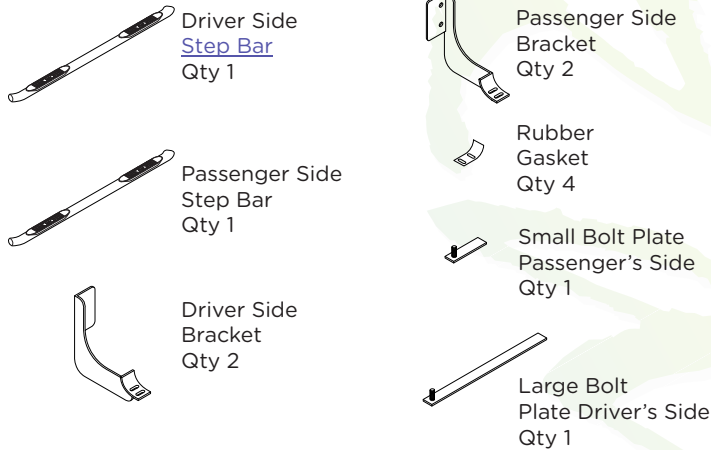

Components:



Hardware:

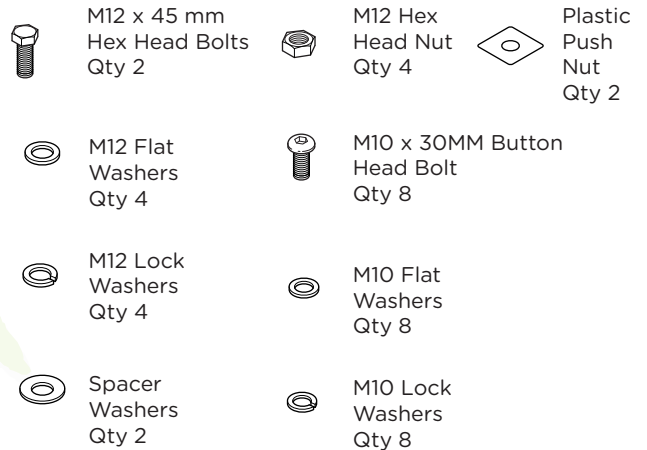

Tools Required:

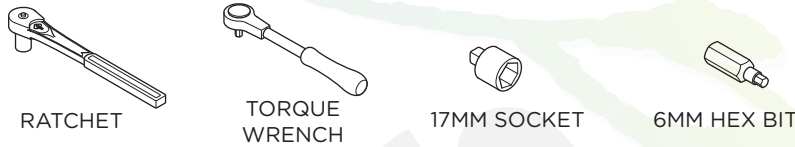

Torque Specifications:

For Frame Mount Installations

Frame Mount bolts are torqued to 70 Ft Lbs. All other M8 through M12 sized bolts/nuts are set to 15-20 ft lbs.

Note: When installing the brackets and bars, all hardware must be left loose until all the items are attached.

1. Remove all contents from the package and check stainless steel tubes for any damage. Also, verify that all components and hardware listed above are included before you begin installation.

2. Existing mounting holes are located on the interior wall of the rocker panel. These mounting holes will be used per the following instruction.

Beginning on the driver's side, align the front and rear driver's side brackets with the vehicle.

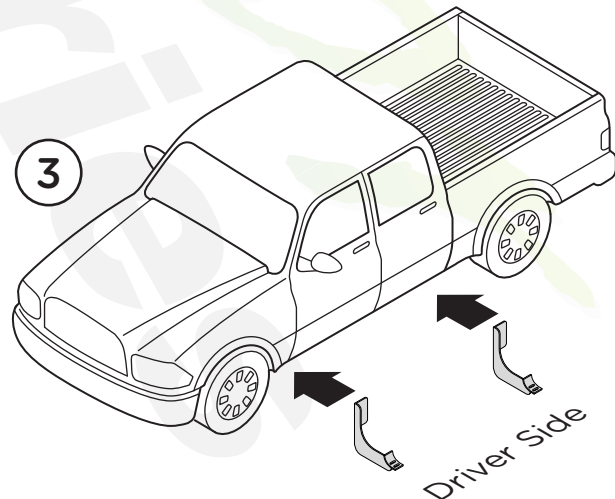

3. Install the Plastic Push Nut onto the Bolt Plate shown (3a). Install the Driver Side Bolt Plate into the hole in the frame (3b). The Plastic Push Nut prevents the bolt from falling into the frame and keeps the bolt straight (3c).

Note: Passenger's Side Bolt Plate is much shorter than the Driver's Side Bolt Plate.

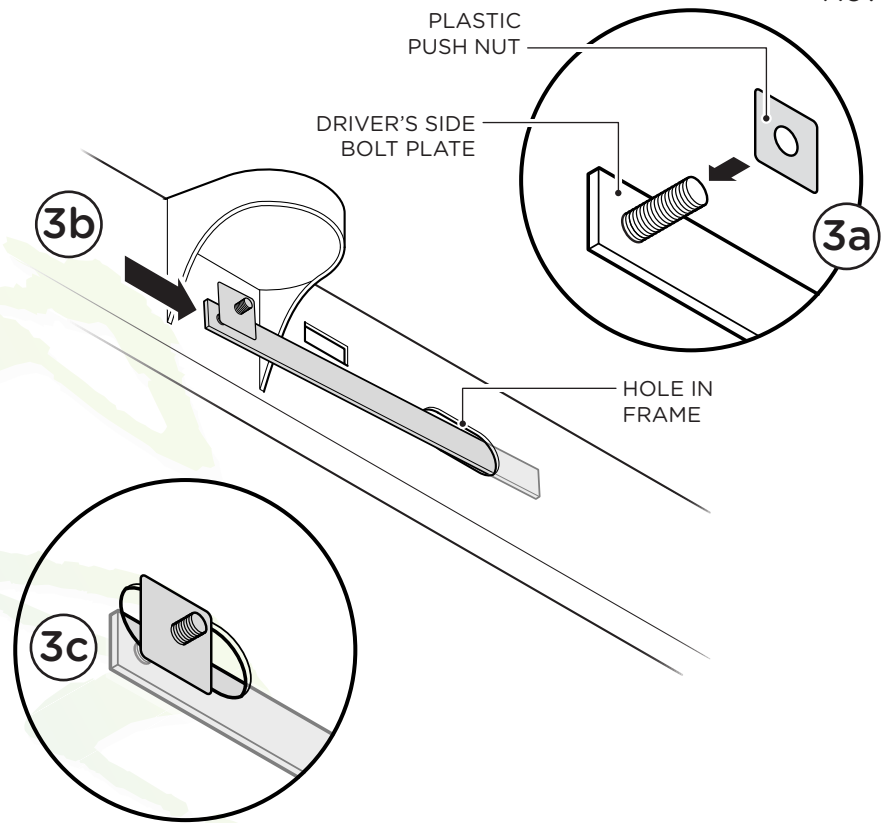

4. Align the Driver's Side Front Bracket with the Driver's Side Bolt Plate and secure using one (1) M12 Flat Washer, one (1) M12 Lock Washer and one (1) M12 Hex Head Nut. Hand tighten all hardware.

5. For installment of the Driver's Side Rear Bracket align the bracket with oblong hole as shown and secure using one (1) M12 X 45MM Hex Head Bolt, one (1) Spacer Washer, one (1) M12 Flat Washer, one (1) M12 Lock Washer and one (1) M12 Hex Head Nut. Hand tighten all hardware.

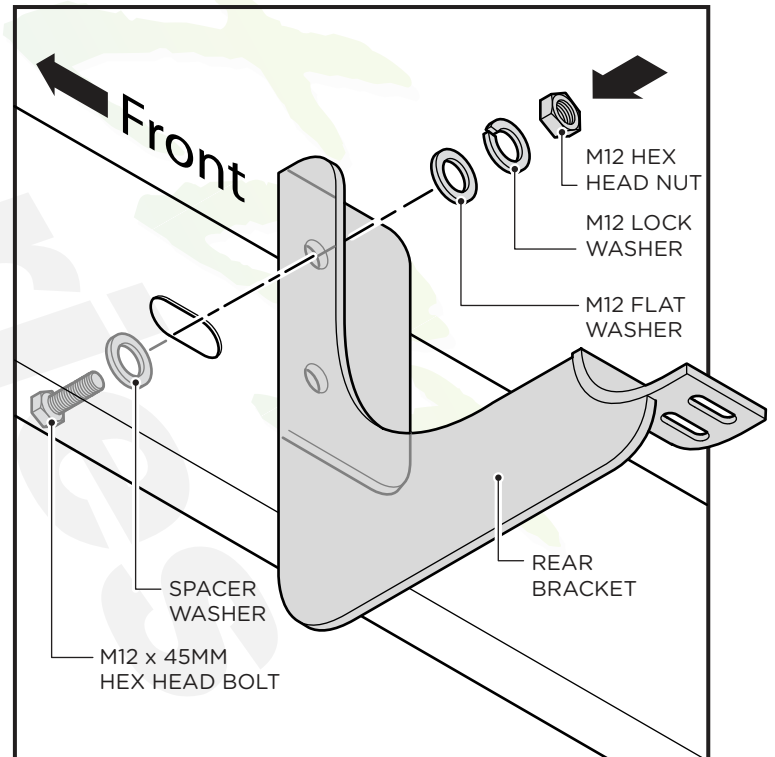
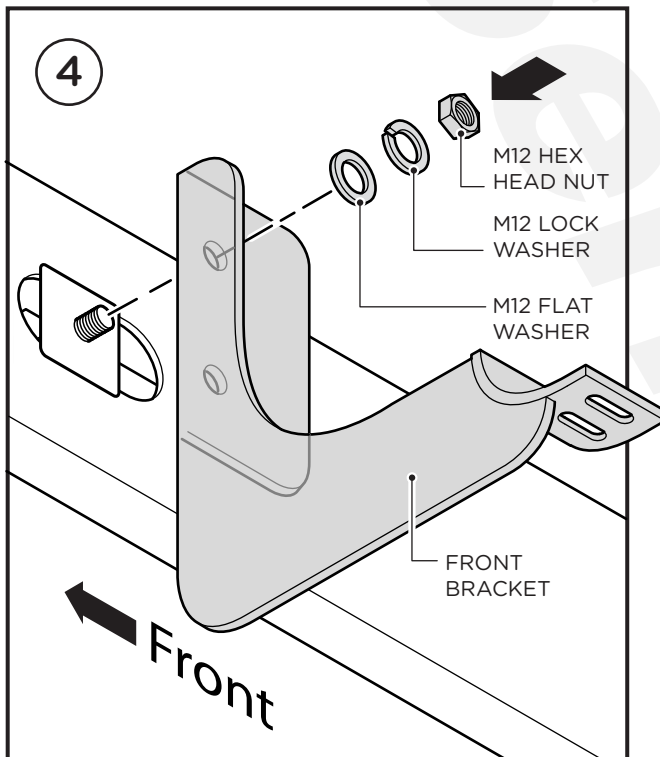

6. Place the Step Bar and the Rubber Gaskets onto the Brackets. Each Step Bar is marked Driver and Passenger.

7. Attach the Step Bar onto each Bracket using two (2) M10 x 30MM Button Head Bolts, two (2) M10 Flat Washers and two (2) M10 Lock Washers per bracket.

Tighten until the split lock washer is flat against bracket and snug. **DO NOT** over tighten and strip the threaded insert in the tube.

Repeat these steps for passenger side installation. When all hardware is in place, everything must be tightened. See Page 1 for Torque Specifications.

