

2010-2015 Dodge Ram 1500/2500/3500 Quad/Crew/Mega Cab With 6'4" & 8' Bed Length Wheel to Wheel Installation Instructions

Hardware Kit Includes Loose:

- (1) 28 – Hex head bolts (M8-1.25 x 30mm) Grade 8.8
- (2) 22 – Hex head Nuts (M8-1.25) Grade 8.8
- (3) 34 – Lock washers (M8) Grade 8.8
- (4) 50 – Flat washers (M8) Grade 8.8
- (5) 6 – M10-1.5Hex head nuts Grade 8.8
- (6) 6 – M10 Flat washer Grade 8.8
- (7) 6 – M10 Lock washer Grade 8.8
- (8) 6 – M10 Plastic push nuts

Components List:

- (1) – Driver/Passenger RT Steps
- (2) – (6) Front/Middle Mounting Brackets (RTSPN015)
- (3) – (6) M8-1.25 Triple T-bolt
- (4) – (6) M10-1.5x 40mm Single T-bolts

**LOOSE FIT ALL COMPONENTS.
DO NOT TIGHTEN UNTIL ALL
COMPONENTS ARE INSTALLED
AND ADJUSTED.**

**DISCLAIMER: USE ONLY COMPONENTS
AND HARDWARE SUPPLIED BY ICI.
NO SUBSTITUTIONS.**

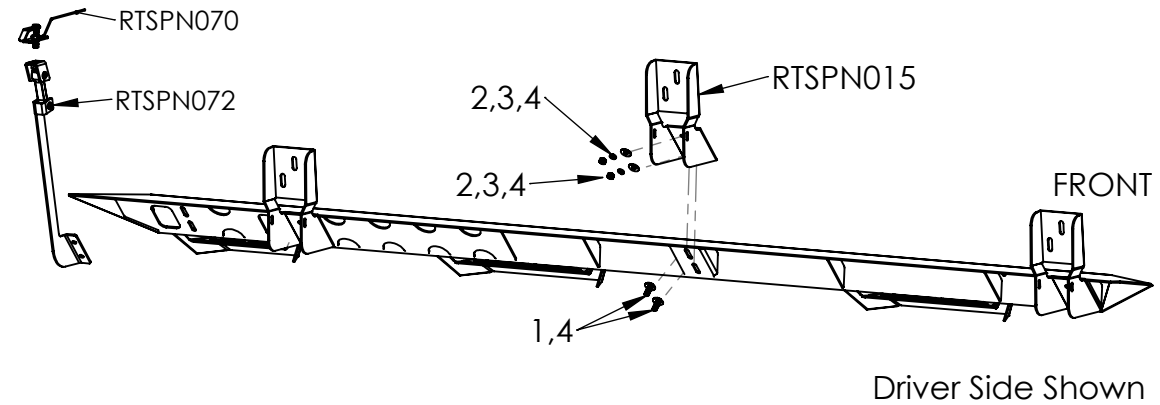
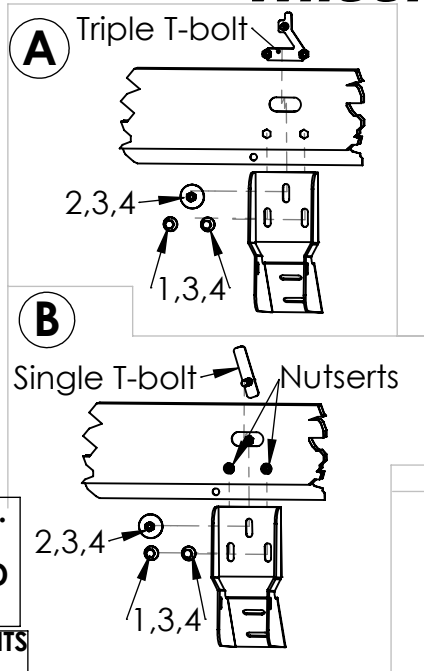

Driver Side Shown
Raptor

Step by Step Installation Instructions

- STEP 1:** Read and understand instructions completely before beginning installation.
- STEP 2:** Remove all factory step brackets and hardware. If your truck was equipped with factory steps and you have threaded Nutserts in the inside rocker panel, leave Nutserts in the panel.
- STEP 3:** Locate the driver's side step and rear bracket (the center of the front foot step is 23.25" from the front of the bar).
- STEP 4:** Using figures A & B, determine if your truck has the threaded Nutserts in the lower inside rocker panel or not. If your truck is equipped with them, then you will use the single t-bolt set up as shown in figure B in the top hole location. If your truck does not have the Nutserts, then use the triple t-bolt as shown in figure A. Once you have determined which t-bolt to use, insert t-bolts with supplied square plastic washers (put plastic washers on t-bolts before installing so they don't fall into rocker panel). Loose fit brackets to rocker panel using supplied hardware (see FIG A or B).
- STEP 5:** Once brackets and support strap are loose fit to truck, loose fit steps to brackets using supplied hardware.
- STEP 6:** Once bar and brackets have been loose fit into position, adjust and tighten the brackets to rocker panel. If using factory Nutserts, tighten by hand and do not over tighten. If using triple t-bolt, fully tighten by hand and **Do not use impact tools.**
- STEP 7:** Next, adjust bar front/back and up/down then tighten steps to brackets. Fully tighten hardware attaching the step to the brackets. **Do not use impact tools.** Repeat for passenger side.

2015 Dodge Ram 1500/2500/3500 Quad/Crew/Mega Cab

With factory Pinch Weld mounting holes

Wheel to Wheel Installation Instructions

Hardware Kit II Includes Loose:

- (1) 12 – Hex head bolts (M6 x 20mm) Grade 8.8
- (2) 24 – Hex head Nuts (M6) Grade 8.8
- (3) 24 – Lock washers (M6) Grade 8.8
- (4) 48 – Flat washers (M6) Grade 8.8
- (5) 12 – Hex head bolts (M6 x 30mm)
- (6) 2 – Hex head Nuts (10mm)
- (7) 4 – Binding Bolts

Components List:

- (1) – (6) Front/Middle Support Brackets (RTSPN049)
- (2) – (2) Rear Support Straps (RTSPN072)
- (3) – (6) Spacers (RTSPN051)
- (4) – (2) Rear Support Strap T-Bolts (RTSPN070)
- (5) – (2) Rear Support Strap Isolators (RTSPN066)
- (6) – (2) Rear Support Strap Adapters (RTSPN065)

**LOOSE FIT ALL COMPONENTS.
DO NOT TIGHTEN UNTIL ALL
COMPONENTS ARE INSTALLED
AND ADJUSTED.**

**DISCLAIMER: USE ONLY COMPONENTS
AND HARDWARE SUPPLIED BY ICI.
NO SUBSTITUTIONS.**

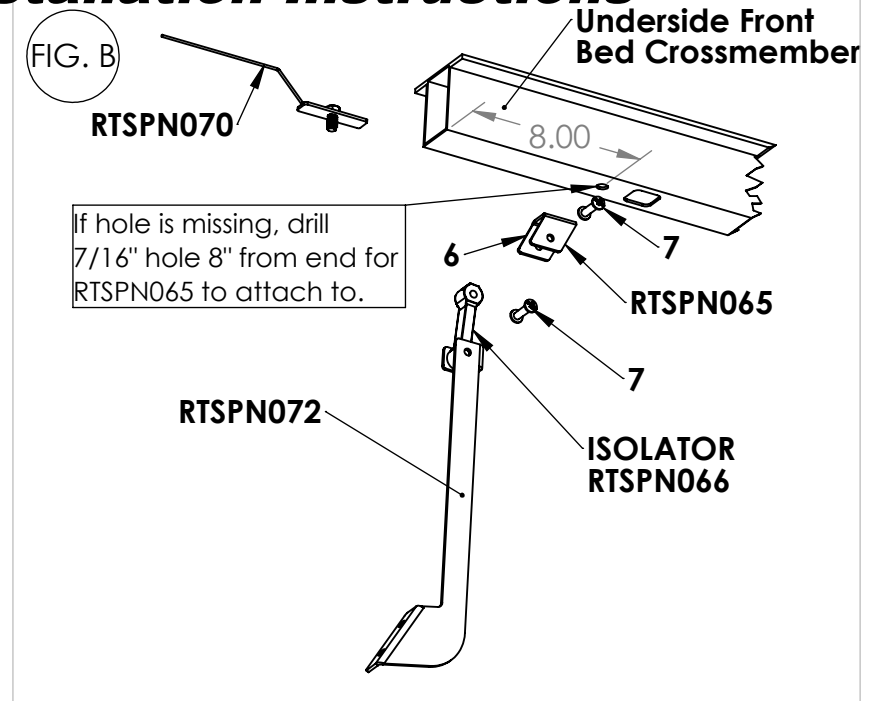
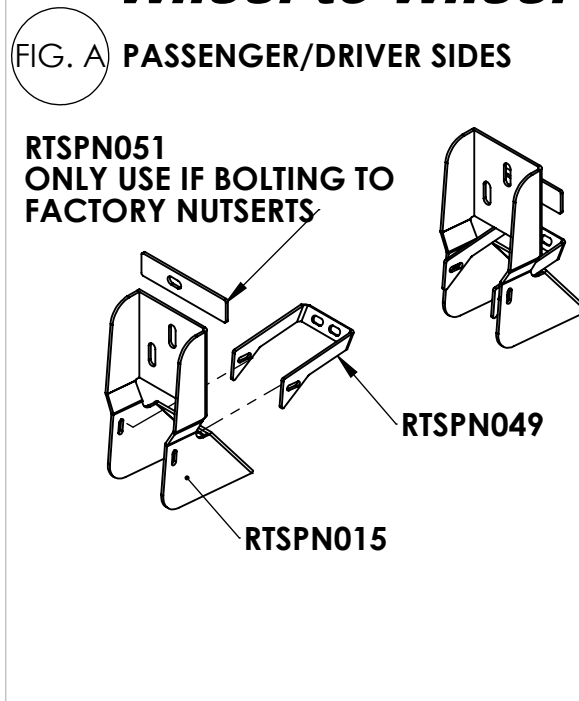

Step by Step Installation Instructions

- STEP 1:** On some model 2015 and later Ram trucks there are pre-drilled holes in the pinch weld along the bottom of the cab. RTSPN049 attaches to these holes and to RT step bracket RTSPN089. *(Brackets may be added to earlier models if so desired by drilling into the pinch weld area).*
- STEP 2:** Using provided 6mm hardware attach RTSPN089 to each of the RTSPN049 brackets and the holes in the pinch weld of the cab. Fully tighten all hardware. See FIG. A.
- STEP 3:** On 2015 Ram trucks: if the truck came with factory side steps and you are reusing the factory Nutserts, there is a provided 1/8" spacer (RTSPN051) so the RT Step brackets sit flush on the factory Nutserts. See FIG. A and FIG. B.
- STEP 4:** Attach rear support strap using provided t-bolt (RTSPN102). Under the bed of the truck towards the front of the bed is a bed floor support cross member with a round hole. Feed the provided t-bolt through the End of the cross member and into the hole as shown in FIG. B. If there is no hole in the cross member, you will need to drill a 7/16" hole, 8" in from the outside edge of the cross member (SEE FIG. C). Attach adapter (RTSPN065) to t-bolt using provide 3/8" nut and tighten. Attach isolator to adapter (RTSPN065) and strap (RTSPN101/136) (If you are installing on a 1500 Quad Cab, then you must use RTSPN136, instead of RTSPN101) using provided binding bolts. Finally, attach strap (RTSPN101/136) to Baja Nerfbar using provided 8mm hardware. Make sure the strap is pulled tightly before tightening to Baja Nerfbar.

NOTE* On any Dodge Ram truck that does not have the holes in the pinch weld area, you may drill these holes using a 1/4" drill bit. This is not required but will significantly reduce the flex in the Magnum RT Step Bars.