

RTW106/113CH

2007-2013 Chevrolet/GMC Ext-Cab1500 2007-2014 HD Gas/Diesel Installation Instructions

Hardware Kit Includes Loose:

- (A) 36 – Hex head bolts (M8-1.25 x 30mm)
Grade 8
- (B) 36 – Lock washers (M8) Grade 8
- (C) 64 – Flat washers (M8) Grade 8
- (D) 28 – Hex head nuts (M8-1.25) Grade 8
- (E) 8 – Long U-Nuts (M8-1.25)
- (F) 4 – Binding Bolts (5/16 x 1.25")

Components List:

- (G) 2 – 1 Driver/1 Passenger RT Step
- (H) 1 – Passenger Front Mounting Bracket
(DIESEL ONLY) RTSPN032
- (I) 6 – Mounting Brackets RTSPN033
- (J) 1 – 1/4" Spacer for RTSPN032
RTSPN035
- (K) 2 – Mounting Brackets
RTSPN074
- (L) 2 – Rear Support Straps RTSPN075
- (M) 2 – Rear Support Strap Adapter
RTSPN065
- (N) 2 – Rear Support Isolators
RTSPN066

**DISCLAIMER: USE ONLY
COMPONENTS AND HARDWARE
SUPPLIED BY ICI.
NO SUBSTITUTIONS.**

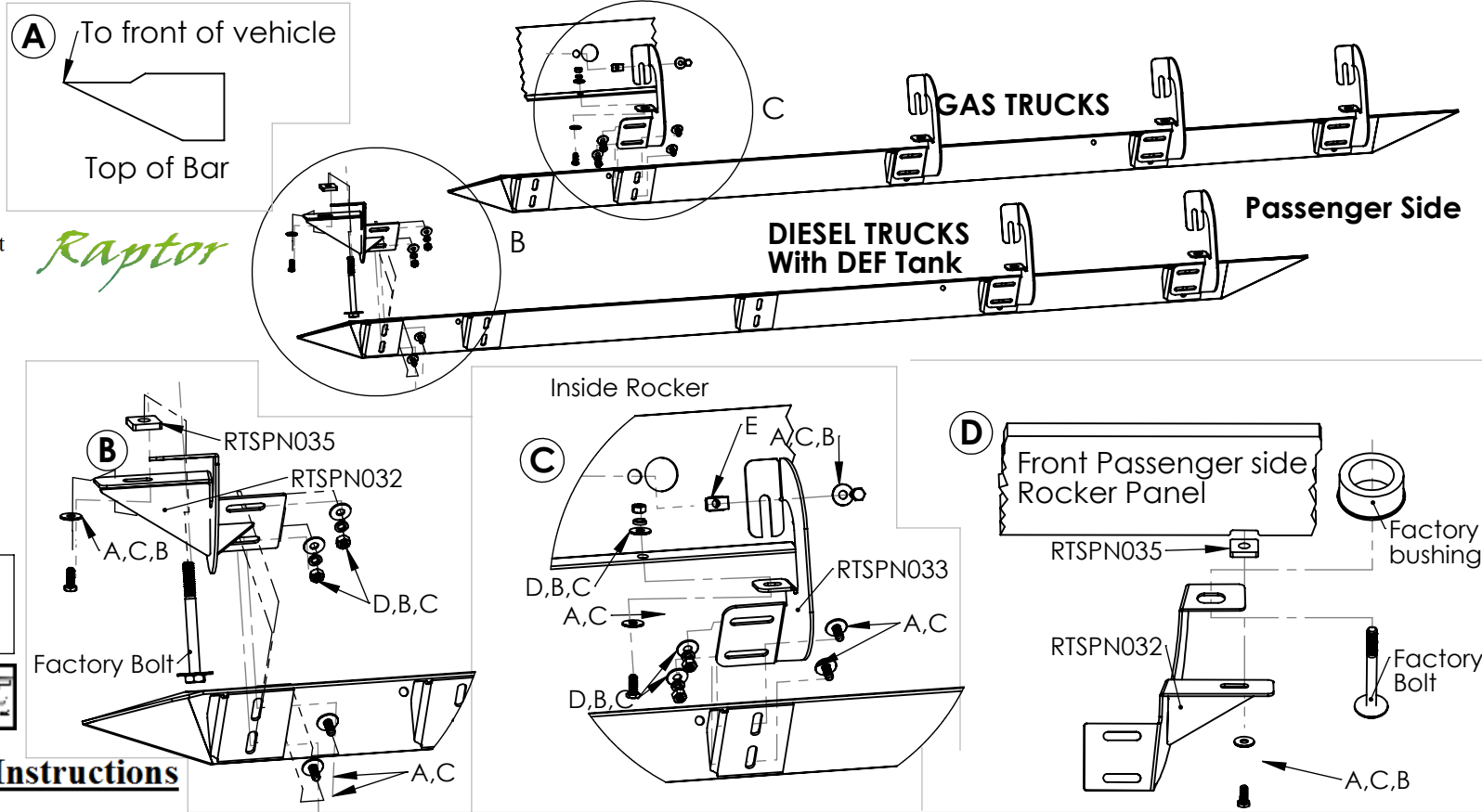

Step by Step Installation Instructions

- STEP 1:** Read and understand instructions completely before beginning installation. Remove all old steps and hardware from truck.
- STEP 2:** Locate the driver's side step (the notched end of the RT Step goes to the front of the vehicle). See FIG A.
- STEP 3:** The driver side step on gas and diesel trucks is mounted with (4) RTSPN033 brackets that bolt to the inside rocker panel and pinch weld area. Notice the orientation of the brackets, there are 4 driver side and 4 passenger sides. Some trucks may have threaded inserts in the inside rocker, if not use provided U-Nuts as shown in (fig C). Using provided 8mm bolt, two flat washers, lock washer and nut, bolt RTSPN033 to the pinch weld directly under where the threaded insert is or U-Nut is attached see (fig C). If you have either a gas or diesel without DEF tank under passenger side door, mount passenger side brackets the same as driver side and proceed to step 5, if you have a diesel with DEF tank proceed to step 4.
- STEP 4:** The front passenger side bracket on DEF diesel trucks use part RTSPN032, this bracket mounts to the front body mount and pinch weld/fender. Remove front body mount bolt and insert RTSPN032, keep the factory body mount bushing on top of RTSPN032 as shown in (fig D). Once RTSPN032 is attached to the body mount, the other mounting tab will line up with a factory threaded insert in the pinch weld, there may be a bolt in this insert. Remove factory bolt and line up RTSPN032, if RTSPN032 does not fit flush with the bottom of the pinch weld insert provided spacer (RTSPN035) and bolt RTSPN032 into place using provided hardware see (fig D).
- STEP 5:** Once RT Step brackets are fitted, loose fit RT Step using provided hardware see (fig B & C). Once RT Step is loose fit, tighten brackets to inside rocker (**DO NOT USE IMPACT TOOLS**). Next, adjust bar up/down and front/back then fully tighten step to brackets.

RTW113CH

2007-2013 Chevrolet/GMC Ext-Cab1500 2007-2014 HD Gas/Diesel Installation Instructions

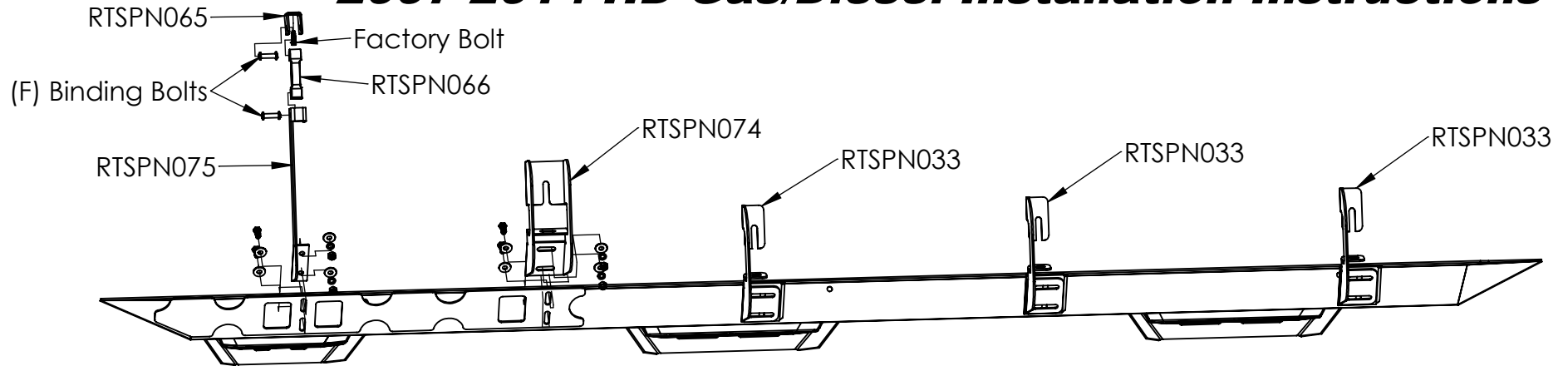

UNDERSIDE FRONT OF BED



Wheel to Wheel Installation Instructions

1. After RT Step is mounted to truck and fully tightened to the cab brackets (RTSPN074 & RTSPN033) Begin installing the rear bed support strap.
2. Locate the mounting bolt underneath the front part of the bed (SEE FIG. 1).
3. Remove the factory bolt and insert through the support strap adapter (RTSPN065) and reinstall bolt with support strap adapter.
4. Using the provided binding bolts attach the rubber isolator to the support strap adapter (RTSPN065) and the support strap (RTSPN075).
5. Once the support strap assembly is attached to the underside of the bed it is important to pretension the support strap before tightening it to the RT Step. First, loose fit the support strap (RTSPN075) to the slotted holes in the RT Step. Second, apply downward pressure to the support strap assembly by pulling on it and tighten the support strap to the RT Step at the same time. If done correctly, the rubber isolator will be tight in the assembly.

Cab

Internal Bedside

Factory Bolt
To Mount Support Strap